

MMECHAN CONTROLS

Installation Instruction for R-Type Proton Advanced Solenoid Interlock



Technical Specification

Technology	RFID
Coding	Individually Coded (4 Billion Codes)
Electrical Data of Safety Outputs	
Safety Contact outputs	2 NO
Maximum Current per Output	500mA, max
External Protection Fuse	400mA Fast Acting
Electrical Data of Auxiliary Output	
Operating Voltage	
Output Type	24Vdc
Maximum Current per Aux Output	1 NC
External Protection Fuse	500mA max
Power Supply Electrical Data	400mA Fast Acting
Supply Voltage Options	
Overvoltage Category	24Vdc (+/- 15%)
General Information	III
Construction	
IP Rating	Red ABS - Glass Fibre Reinforced & Black ABS - Glass Fibre Reinforced
Operating Temperature	IP67
Fixing	-10°C to +60°C
Connection	4 X M5 Security Screws
Indication	Pre-Wired or M12 QD
Mechanical Data	
Mechanical Endurance	See page 4
Max. holding force	
Released actuator extraction force:	1 million operating cycles
	2000 N
	~ 10 N

Safety Related Data			
B10d	10,000000	PFH	1.1 x 10 ⁻⁹
TM (Mission Time)	>100 Years	PFHd	1.12 x 10 ⁻⁹
DC	99%	SFF	99.5%
MTTFd	High > 385 Years (Based on usage rate of 360 Days/Year, 24 Hours/Day, 10 Operations/Hour)		
SIL up to	SIL 3 acc. to EN 62061		
Performance Level (PL) up to	PL-e acc. to EN ISO 13849-1		
Safety Category up to	CAT4 acc. to EN ISO 13849-1		
Coding	High - Type 4 acc. to EN ISO 14119		

Safety Standards	
Approvals	CE Complies with all relevant sections of the CE Marking Directive TUV Approved cULus 508 Industrial Control Machinery Directive 2006/42/EC, Low Voltage Directive 2014/35/EU; EMC Directive 2014/30/EU, RoHS Directive 2011/65/EC EN 12100 Safety of Machinery. General principles for design. EN ISO 14119 Safety of Machinery. Interlocking devices associated with
International Directives	guards. Principles for design and selection. EN ISO 13849 Safety of Machinery. Safety related parts of control systems.
International Standards	EN ISO 62061 Safety of Machinery. Functional safety of safety related electrical, electronic and programmable electronic control systems
	EN 60204 Safety of Machinery. Electrical equipment of machines
	EN 60947-5-1 Low-voltage switchgear and controlgear.
	EN 60947-5-3 Low-voltage switchgear and controlgear.

Proton Features and Benefits



- Uniquely Coded RFID Technology (4 Billion Possible Codes)
- Maintain PL-e
- Advanced LED Diagnostic Display
- 500mA Safety Output Rating
- 2000 Newton Holding Force
- Ball Style Actuator for Larger Misalignment Tolerance
- Power To Unlock

The Proton advance solenoid interlock has been designed for use on machines where hazardous conditions persist even after the machine has been switched off. The robust design and heavy-duty solenoid can withstand up to 2000N hold force and energise under a lateral load. The internal specifications meet the requirements for CAT4, SIL3 and has been designed to maintain PL-e even when connected to a safety relay or PLC. The unique mounting holes allows for easy installation on 3-faces, ideal for both hinged and sliding door applications. The Proton R-Type offers protection against manipulation, interference and defeat making them ideal for use in high risk applications. Mechan's unique coding technology allows for 4 billion possible codes. Should either part be lost or damaged, the teach-in facility allows for unlimited re-teaching.

The spring-loaded actuator means the Proton excels at misalignment tolerances. It's failsafe design also includes a uniquely coded RFID signal (4 billion codes), so only when the actuator plunger and RFID signal are satisfied, will the Proton operate. The Proton R-Type uses RFID technology that meets the requirements of type 4 high level coding in accordance with EN ISO 14119

The Proton R-Type solenoid interlock features volt free contact output technology. Each switch includes 2 normally open and 1 normally closed outputs that are designed to be connected to a Mechan Safety Relay (SRL-1 or EM1 & ESM) or any Safety PLC. The Proton R-Type includes 6 LEDs, 3 on each side that display the same data and provide visual diagnostics for ALL states of the device. The Proton R-Type is designed to work with safety relays that have a low inrush current.

The R-type has up to 2 x N/O + 1 N/C bi-directional solid state outputs along with built in LED(s) for indication. (see page 3)

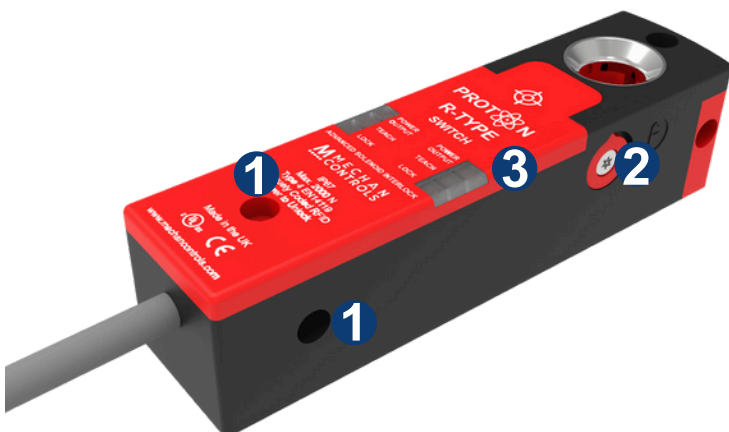

- 1 Front and side mounting holes for 3 operating faces.
- 2 Solenoid release key accessible from both sides.
- 3 Indication on both sides for visibility on all mounting angles.

Indication

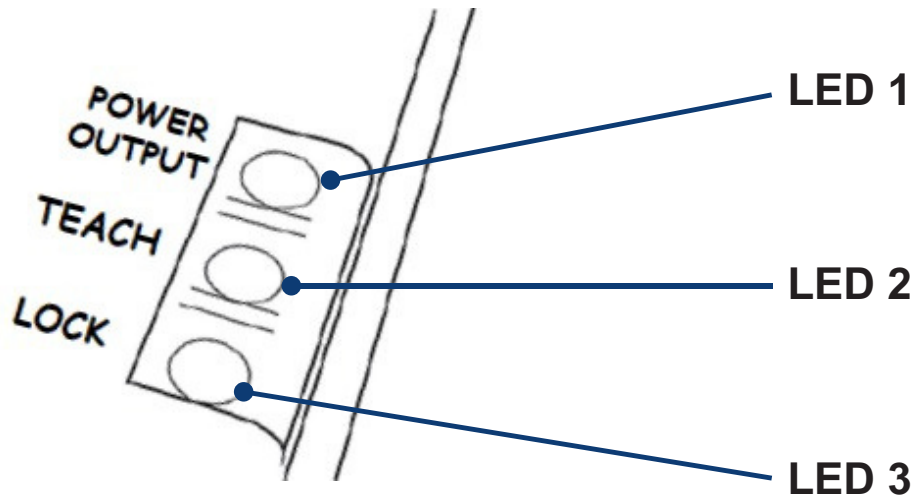

LED 1		
Colour	LED Status	Description
	None	No supply or teach mode (check LED 2)
	Solid Red	Supply is in operating parameters no actuator present
	Solid Yellow	Supply is outside operating voltage check supply and cycle supply
	Flashing Yellow	Wrong RFID code check actuator
	Solid Green	Guard is closed the safety outputs are closed and the auxiliary is open

LED 2		
Colour	LED Status	Description
	Flashing Purple	Switch is set to teach voltage (17v) and is ready to be taught
	Solid Purple	Switch has been taught the new actuators code

LED 3		
Colour	LED Status	Description
	Solid Red Solid	Solenoid energise unlocked
	Green Solid	Solenoid de-energised locked
	Yellow Flashing	Plunger back but should be forward check manual override
	Yellow	Solenoid could not energise and is cooling this will clear after 30 seconds. Possibly to much pressure on the plunger
	Flashing Green	Solenoid attempting to energise but plunger can not pull back. Possibly to much pressure on the plunger
	Flashing Red	Plunger to far forward because the locking pin is not in position check actuator is fitted correctly. If actuator is fitted correctly one of the internal sensors has failed return unit to Mechan.

Installation

Installing an Proton Safety Interlock

- Drill holes or use a mounting plate to secure the switch and actuator
- Use the security screws provided in the packaging

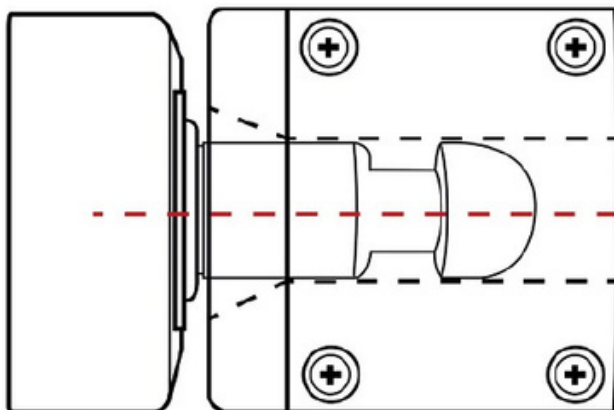

Ensure the actuator plunger and targets are correctly aligned. The spring loaded actuator is self aligning and gives approx. 15 degree missalignment tolerance. Note: It is recommended you have access to one of the emergency solenoid release keys located on both sides of the switch.

Wiring & Connection

Pre-Wired Connections

Wire	Brown	Connection	+24Vdc
Blue	Pink	Supply	0V N/O
White		Safety 1 Output	N/O
Red/Orange		Safety 1 Output	N/O
Orange		Safety 2 Output	N/O
Green		Safety 2 Output	N/C
Yellow	Grey	Auxillary Output	N/C
		Auxillary	Output
		Solenoid Supply	

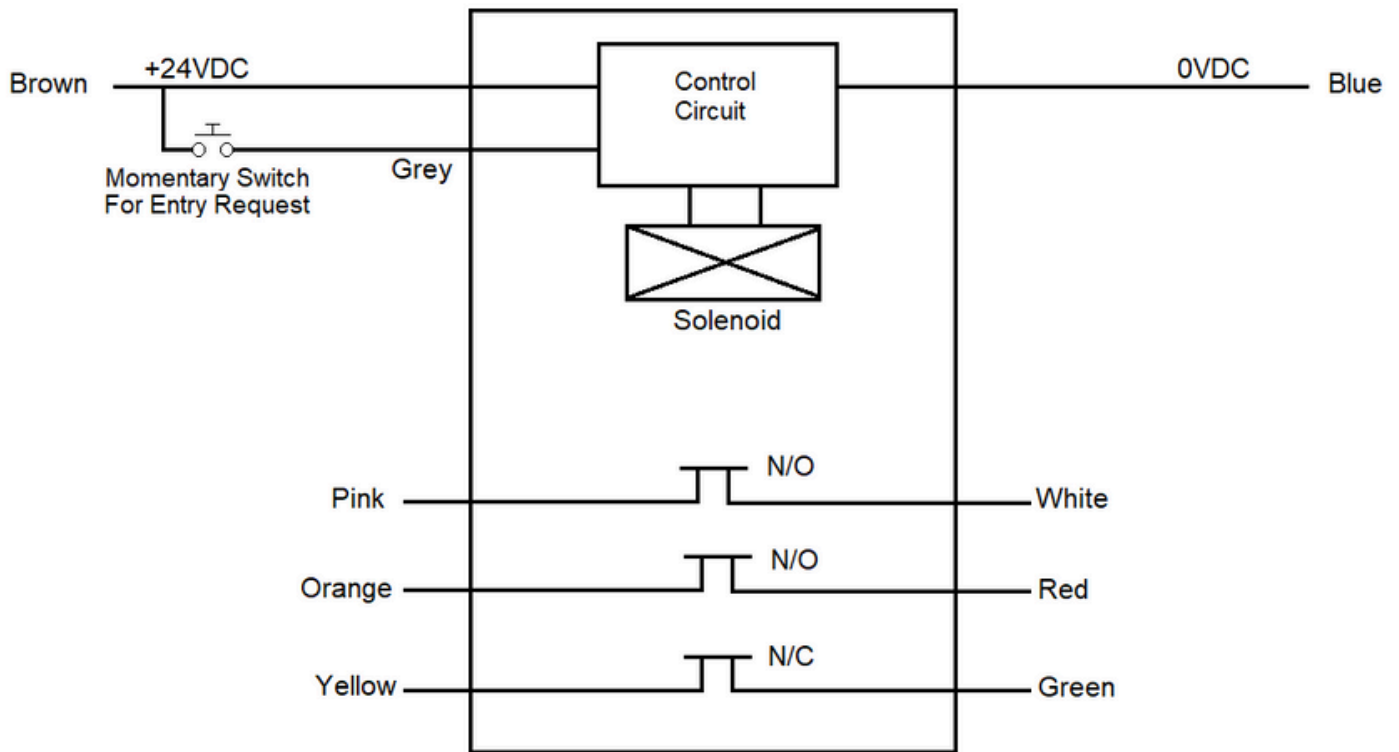

Wiring Example to a safety relay

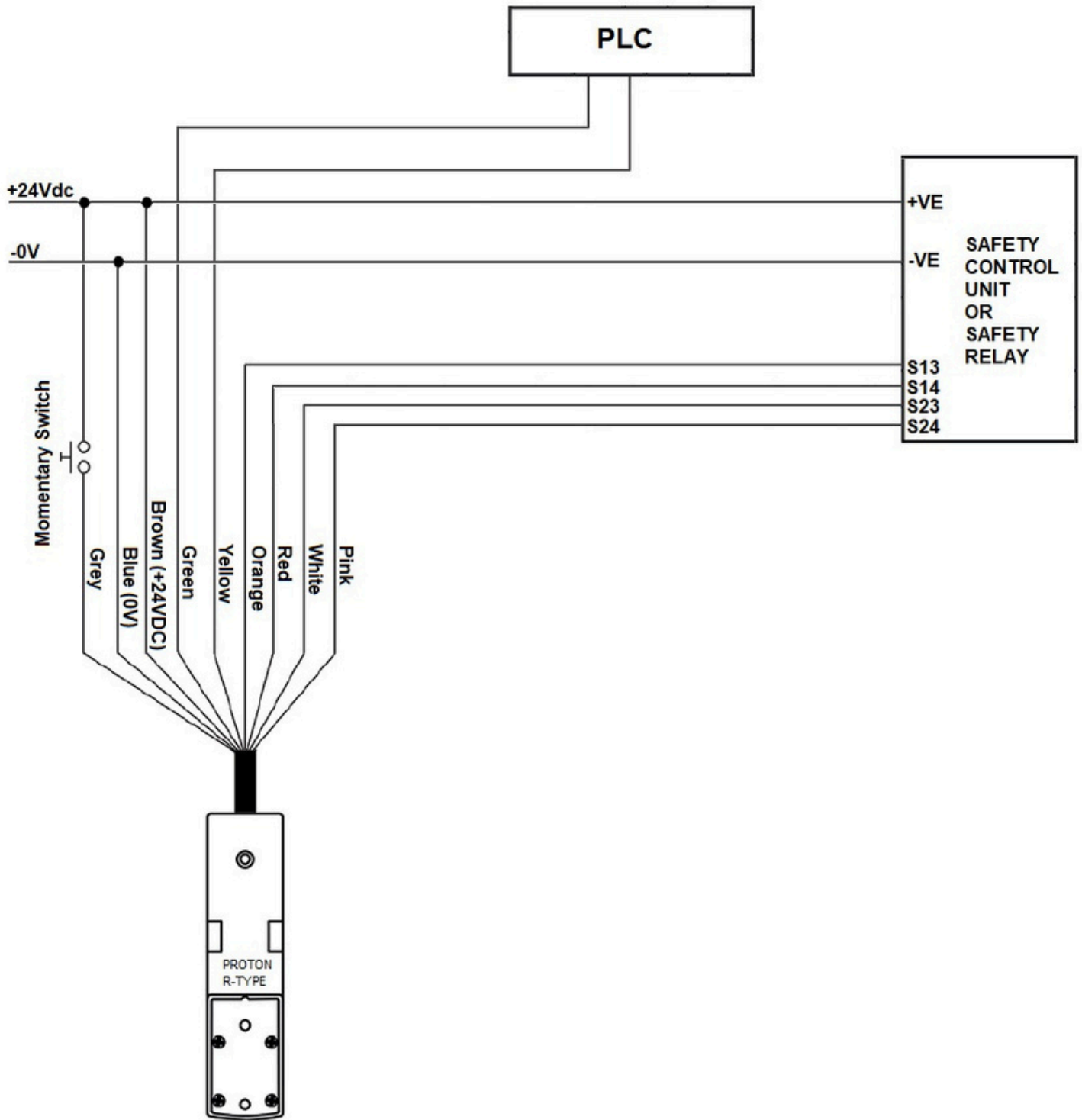

Product Selection

PROTON-R-21-24DC-03M

Product Type

Proton Power to Unlock

R-Type

R Volt Free Contact Output

Safety Channels

2 2 Outputs

Signalling Output

1 1 Auxiliary Output

Supply Voltage

24DC 24Vdc

Connection Type

03M 3 Metre Pre-Wired

06M 6 Metre Pre-Wired

10M 10 Metre Pre-Wired

Stock Code	Part Description	Safety Output	Auxillary Output	Connection
	PROTON-R-21-24DC-03M	2	1	03 metre 9-core pre-wired
	PROTON-R-21-24DC-06M	2	1	06 metre 9-core pre-wired
	PROTON-R-21-24DC-10M	2	1	10 metre 9-core pre-wired
	PROTON-ACT	-	-	PROTON Actuator Only

Bracket Accessories

Stock Code	Part Description	Type Please see
	Sliding Door Bracket	page 8 Please see
	Hinge Door Bracket	page 8

Bracket Accessories Options

Sliding Door Bracket



316 stainless steel bracket designed for sliding door applications.

Hinged Door Bracket



316 stainless steel bracket designed for hinged door applications.

Dimensions

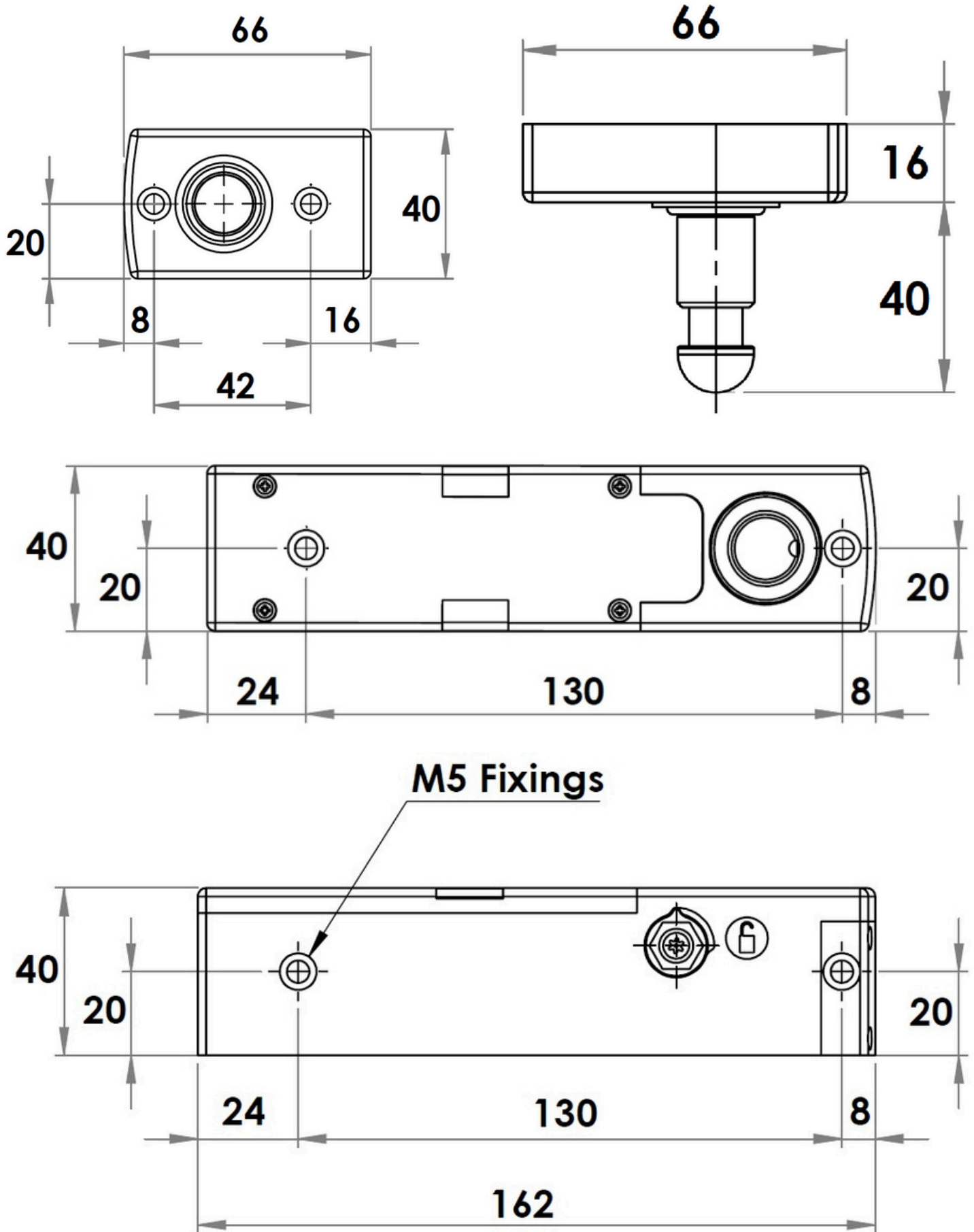

****All dimensions are in MM***

Technical Specification

Safety Assessment

A risk assessment should take place to establish that the specifications of the Proton R-type are suitable for the application required. See Technical Specifications below or contact Mechan Controls for further information.

The products may only be installed, commissioned, operated, maintained by competent persons.

A competent person is a qualified and knowledgeable person who, because of their training, experience and current professional activity, has the specialist knowledge required. An understanding of European and International laws, directives and standards is recommended.

Maintenance

It is recommended to check the safe operation of the Proton and look for signs of damage or excessive wear on a weekly basis. Damaged units should be replaced or returned to the manufacturer for repair where practical.

Disclaimer

In the interest of product development specifications are subject to change without notice. It is the responsibility of the user to ensure compliance with any acts or by-laws in place. All information regarding Mechan equipment is believed to be accurate at the time of printing. Responsibility cannot be accepted for errors or omissions.

Warranty

Warranty will be void if the following points are true:

- The product was not used for its intended purpose
- Damaged was caused by usage not stated in the manual
- Modifications have been made to the products (e.g exchanging components)
- Operating personnel are not suitably qualified

Warning!



The Proton locking switches are uniquely coded and cannot be manipulated or overridden. Removing the actuator from the guard may lead to loss of safety resulting in serious injury or death.

Security screws are provided with every Proton locking unit.



Mechan Controls safety products

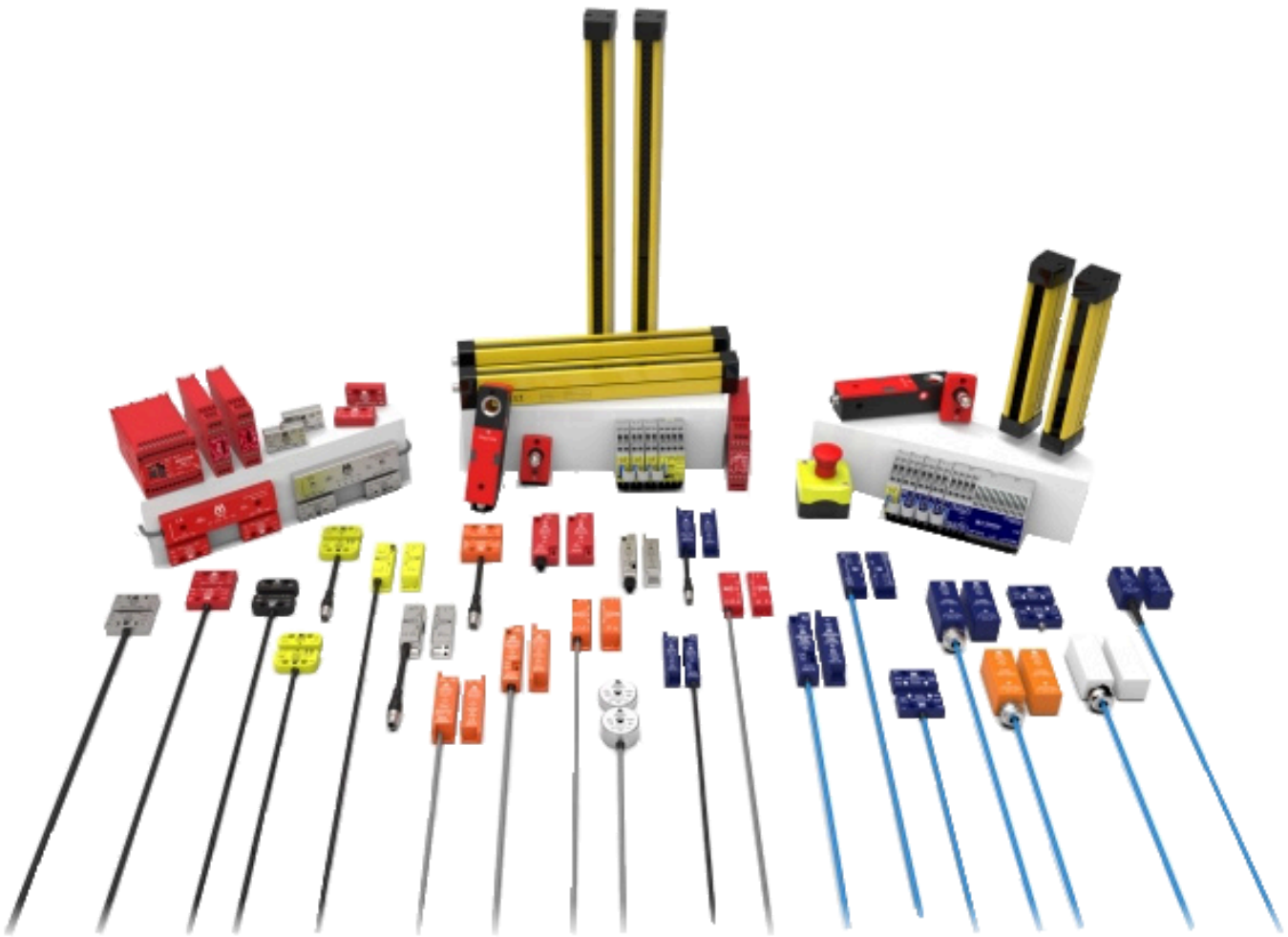

14/16 Seddon Place Stanley Industrial Estate Skelmersdale Lancashire WN8 8EB
Telephone: +44 (0) 1695 722264 Fax: +44 (0) 1695 729664 Email: sales@mechancontrols.co.uk
www.mechancontrols.com