

M MECHAN CONTROLS

O-Type Safety Switches

*OHE1 Coded Magnetic and ODNK / OSSG Uniquely Coded RFID with
OSSD Outputs*



O-Type Features and Benefits



- OHE1 Coded Magnetic
- ODNK / OSSG Uniquely Coded RFID
- Maintain PL-e when Connected in Series using OSSD Outputs
- Advanced LED Diagnostic Display
- External Device Monitoring (Advanced type)
- 2 Amp Safety Output Rating (Pre-Wired) 1Amp (Quick Disconnect)
- Multiple Operating Angles for Easy Installation (ODNK)
- Meets the Requirements for CAT4 and SIL3

The O-Type range combines 40+ years of experience designing and manufacturing machine guard safety products with the latest in safety technology. Their unique design means 30 O-Type switches can be connected in series maintaining PL-e status.

| OHE1 | ODNK / OSSG |
|---|--|
| <p>The OHE1 uses coded magnetic technology that meets the requirements of type 4 coding in accordance with EN ISO 14119. The OHE1 also includes misalignment indication to improved installation.</p> | <p>The ODNK / OSSG has individually coded RFID technology that meets the requirements of type 4 in accordance with EN ISO 14119. Due to the unique design, the switch can be mounted and operated on 4 sides making it incredibly versatile.</p> |

O-Type safety switches include two LEDs for indication. They are able to provide visual diagnostics for ALL states of the device. This means the user can easily fault find without needing to access the control panel.

The O-Type safety switches are available with a feature called EDM (external device monitoring, this means the outputs can be used to monitor the state of contactors without the need for a safety control unit.



Designed for Series Connection

The O-Type range features OSSD outputs designed to maintain a high level of functional safety even through series connection.



Overhanging LED Display

Our new LED design means you can see the indication when mounted on multiple faces.



Slim Line Design for Small Guards

The slim line design means the O-Type are suitable for applications with smaller guarding.

Technical Specification

| | ODNK / OSSG | OHE1 |
|--|---|---|
| Technology | RFID | Coded Magnetic |
| Coding | Individually Coded (4 Billion Codes) | Magnetically Coded (One Generic Code) |
| Electrical Data of Safety Outputs | | |
| Safety Contact Type | PNP type OSSD | PNP type OSSD |
| No. of OSSD Inputs (Max) | 2 | 2 |
| No. of OSSD Outputs | 2 | 2 |
| OSSD Pulse Width | 400 µs | 400 µs |
| Maximum Current per Output | 2 A, max.; Status ON (+24V DC) - Door Closed | 2 A, max.; Status ON (+24V DC) - Door Closed |
| Switching Characteristics | 10mm ON / 20mm OFF (Max) | 8mm ON / 17mm OFF (Max) |
| Misalignment Characteristics | A misalignment of +/- 4mm | A misalignment of +/- 4mm |
| Minimum gap between switch and actuator | 2mm | 1mm |
| Short Circuit Detection | YES | YES |
| Over Current Protection | YES | YES |
| External Protection Fuse | 1.8 A Fast Acting | 1.8 A Fast Acting |
| Electrical Data of Auxiliary Output | | |
| Output Type | PNP | PNP |
| Maximum Current per Aux Output | 2 A, max.; Status ON (+24V DC) - Door Open | 2 A, max.; Status ON (+24V DC) - Door Open |
| Over Current Protection | YES | YES |
| External Protection Fuse | 1.8 A Fast Acting | 1.8 A Fast Acting |
| Power Supply Electrical Data | | |
| Supply Voltage Options | 24VDC (+/- 15%) | 24VDC (+/- 15%) |
| Switch Power Consumption (Max) | 50mA | 50mA |
| Overvoltage Category | III | III |
| General Information | | |
| Construction | Yellow ABS | Black ABS |
| IP Rating | IP67 / IP69K | IP67 / IP69K |
| Operating Temperature | -10°C to +60°C | -10°C to +60°C |
| Fixing | 4 X M4 Security Screws | 4 X M4 Security Screws |
| Connection | Pre-Wired or M12 QD | Pre-Wired or M12 QD |

| Safety Related Data | | | |
|------------------------------|---|------|-------------------------|
| B10d | 10,000000 | PFH | 1.1 x 10 ⁻⁹ |
| TM (Mission Time) | >100 Years | PFHd | 1.12 x 10 ⁻⁹ |
| DC | 99% | SFF | 99.5% |
| MTTFd | High > 385 Years (Based on usage rate of 360 Days/Year, 24 Hours/Day, 10 Operations/Hour) | | |
| SIL up to | SIL 3 acc. to EN 62061 | | |
| Performance Level (PL) up to | PL-e acc. to EN ISO 13849-1 | | |
| Safety Category up to | CAT4 acc. to EN ISO 13849-1 | | |
| Coding | ODNK Type 4 acc. to EN ISO 14119 / OHE1 Type 2 acc. to EN ISO 14119 | | |

| Safety Standards | |
|--------------------------|---|
| Approvals | CE Complies with all relevant sections of the CE Marking Directive |
| | TUV Approved (Pending) |
| | cULus 508 Industrial Control |
| International Directives | Machinery Directive 2006/42/EC, Low Voltage Directive 2014/35/EU; EMC Directive 2014/30/EU, RoHS Directive 2011/65/EC |
| International Standards | EN 12100 Safety of Machinery. General principles for design. |
| | EN ISO 14119 Safety of Machinery. Interlocking devices associated with guards. Principles for design and selection. EN ISO 13849 Safety of Machinery. Safety related parts of control systems. |
| | EN ISO 62061 Safety of Machinery. Functional safety of safety related electrical, electronic and programmable electronic control systems |
| | EN 60204 Safety of Machinery. Electrical equipment of machines. |
| | EN 60947-5-1 Low-voltage switchgear and controlgear. EN 60947-5-3 Low-voltage switchgear and controlgear. |

Dimensions

ODNK/OHE1 SWITCH

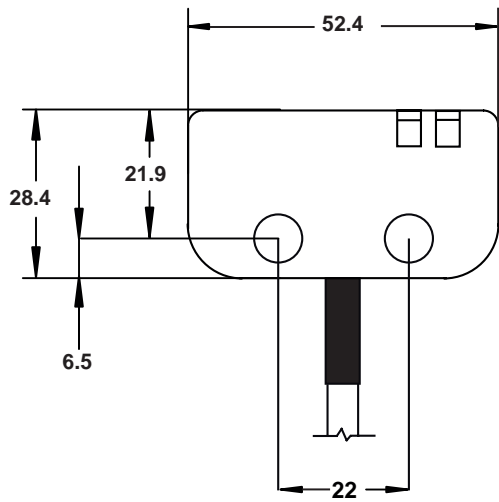

ODNK/OHE1 ACTUATOR

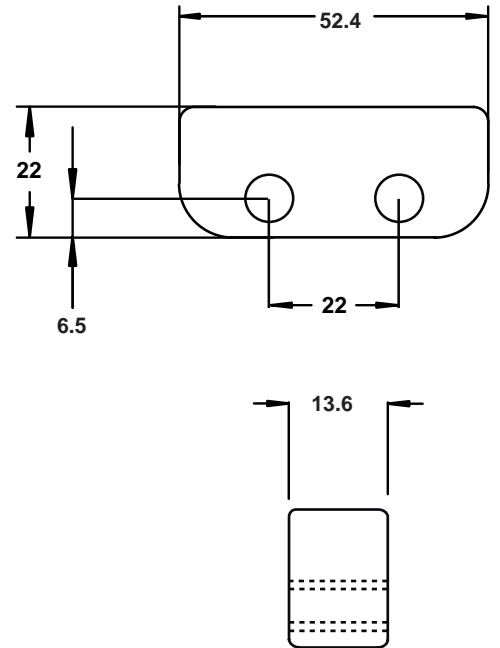

OSSG SWITCH

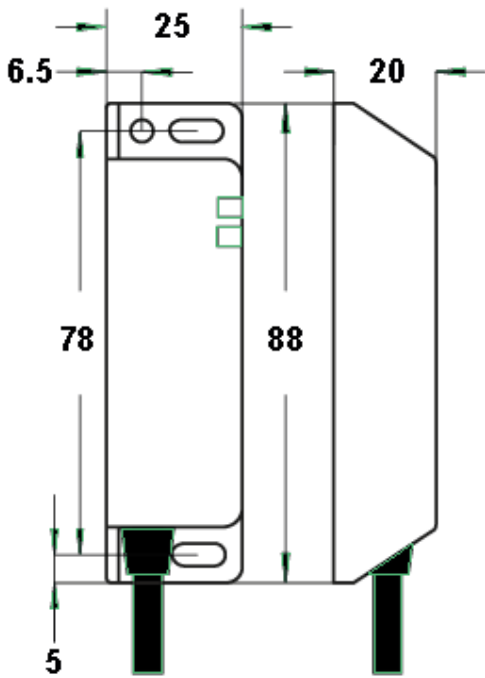

OSSG ACTUATOR

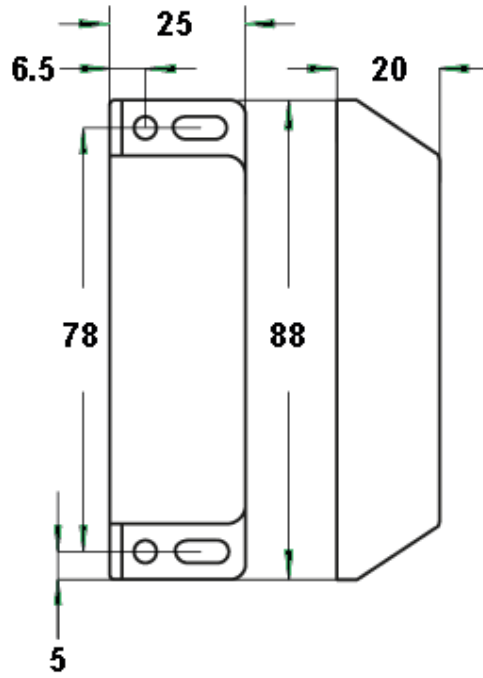

M12 Leaded Quick Disconnect

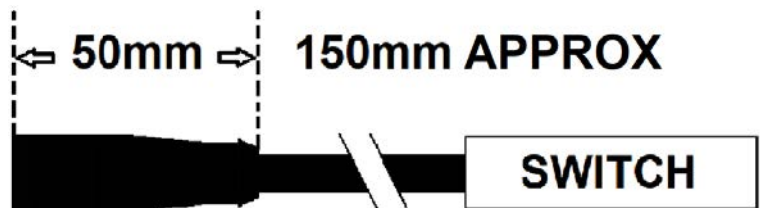

**All dimensions are in MM*

Lateral and Vertical Mounting

Mounting

Do not use safety switches as a stop.

Mount the switch on to the machine frame and the actuator on to the opening edge of the door.

Always try to mount the switch on non-ferrous material. (Ferrous materials may reduce the switching distance.)

NOTES:

Minimum separation 50mm between adjacent switches

DO NOT mount on hinged side of the guard.

Leave a minimum gap of 2mm between the switch and actuator.

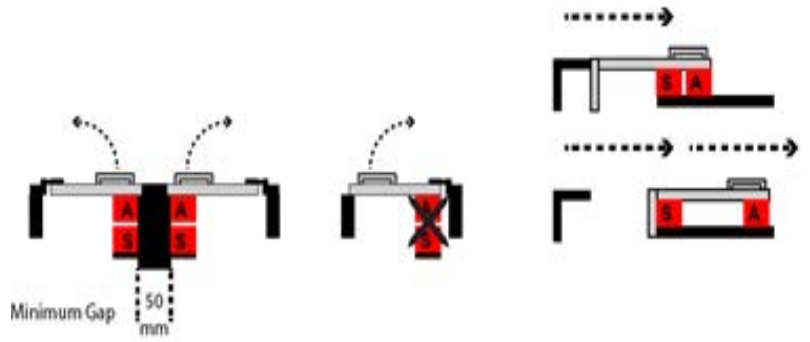

Operating Face and Misalignment

Operating Faces

Designed to operate on **ALL** guard positions. The ODNK and OSSG are extremely versatile.

The ODNK and OSSG will operate on two faces.

Whereas the OHE1 will only operate on the front face.

All O-Series switches have a +/- 4mm misalignment.



ODNK operates on two faces



OSSG operates on two faces

Misalignment indication

The OHE1 has a feature that will show the user if the switch is not aligned correctly. All O-Series switches have a +/- 4mm misalignment.



OHE1 operates on one face.

Installing an O-Type Safety Switch

- Drill holes or use a mounting plate to secure the switch and actuator
- Use the security screws provided in the packaging
- It is important that the switch and actuator are correctly alligned (See page 3 and 4)
- **Leave a minimum gap of 2mm between the switch and acuator**

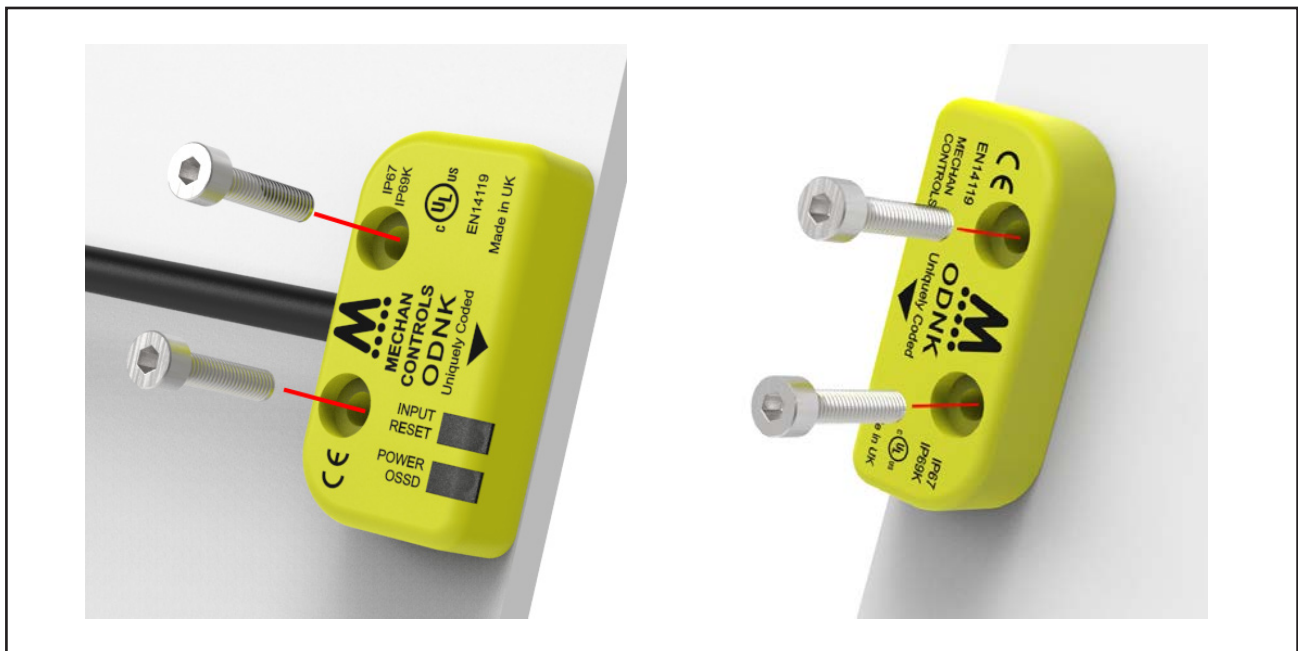

Teach Mode (ODNK / OSSG Only)

If during installation you lose or break the accompanying actuator, it is possible to re-teach a new part by following these steps:

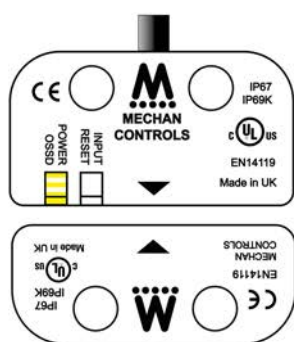

Step 1

Power/OSSD LED Flashing yellow indicates a incorrect coded actuator has been detected.

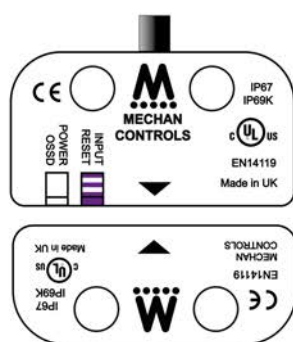

Step 2

Drop the supply to 0v then bring back up to 17v. Input/Reset LED will begin to flash purple meaning it is ready to accept a new code.

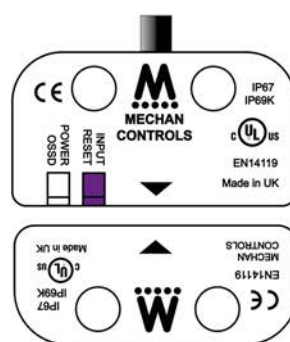

Step 3

Bring the new actuator with-in operating distance of the switch. Input/Reset LED will stop flashing and turn solid purple. This means the new code has been accepted.

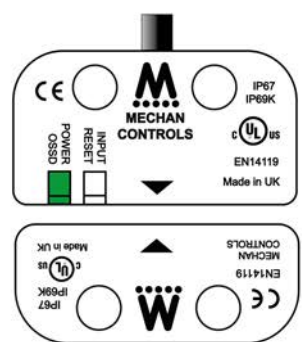

Step 4

Increase the supply to 24Vdc. Input/Reset LED will switch OFF or turn blue (If connected in monitored reset.) and Power/OSSD LED will change to green.

Wiring & Connection

M12 Connections

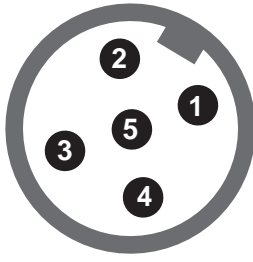

Simple Connection Type
(M12, 5 pins, Male)

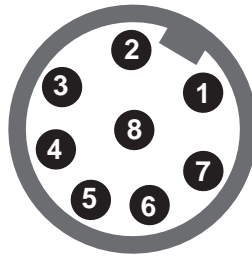

Standard Connection Type
(M12, 8 pins, Male)

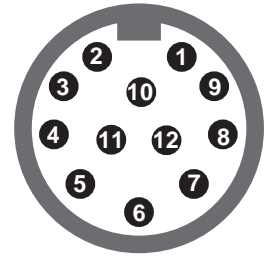

Advanced Connection Type
(M12, 12 pins, Male)

| PIN | Function | Wire Colour |
|-----|---------------|-------------|
| 1 | +24VDC | Brown |
| 2 | Auxiliary | White |
| 3 | 0V | Blue |
| 4 | OSSD 2 Output | Black |
| 5 | OSSD 1 Output | Grey |

| PIN | Function | Wire Colour |
|-----|---------------|-------------|
| 1 | Auxiliary | White |
| 2 | +24VDC | Brown |
| 3 | NOT USED | Green |
| 4 | OSSD 2 Input | Yellow |
| 5 | OSSD 1 Output | Grey |
| 6 | OSSD 2 Output | Pink |
| 7 | 0V | Blue |
| 8 | OSSD 1 Input | Red |

| PIN | Function | Wire Colour |
|-----|-------------------|-------------|
| 1 | Auxiliary | White |
| 2 | +24Vdc | Brown |
| 3 | NOT USED | Green |
| 4 | OSSD 2 Input | Yellow |
| 5 | OSSD 1 Output | Grey |
| 6 | OSSD 2 Output | Pink |
| 7 | 0V | Blue |
| 8 | OSSD 1 Input | Red |
| 9 | Reset / EDM Input | Black |
| 10 | A / M Select | Violet |
| 11 | NOT USED | Grey / Pink |
| 12 | NOT USED | Red / Blue |

Pre-Wired Connections

| Function | Standard | Advanced |
|---------------|-------------------|---------------------|
| +24VDC | Brown | Brown |
| 0V | Blue | Blue |
| OSSD 1 Output | Grey | Grey |
| OSSD 2 Output | Pink | Pink |
| Auxiliary | White | White |
| OSSD 1 Input | Red | Red |
| OSSD 2 Input | Yellow | Yellow |
| A/M Select | Orange (not used) | Orange (see note 1) |
| Reset / EDM | Green (not used) | Green (see note 1) |

Note 1: Advanced Connection

Orange Connect to 0v for automatic reset or +24Vdc for monitored reset. If multiple switches are wired in series, the reset will be controlled by the last connected switch.

Green Connect to a momentary push button if installed in monitored reset configuration or +24Vdc if wired for automatic reset. If multiple switches are wired in series, the reset will be controlled by the last connected switch.

Wiring Example

Series connection for ODNK, OSSG or OHE1 with automatic reset to a safety PLC or Mechan GM1

| | |
|-----------------------------------|------|
| Maximum Cable Length | 30 m |
| Maximum Number of Connected Units | 30 |

The O-Type can be connected, provided that compatibility is checked, to safety modules or safety PLCs with OSSD inputs.

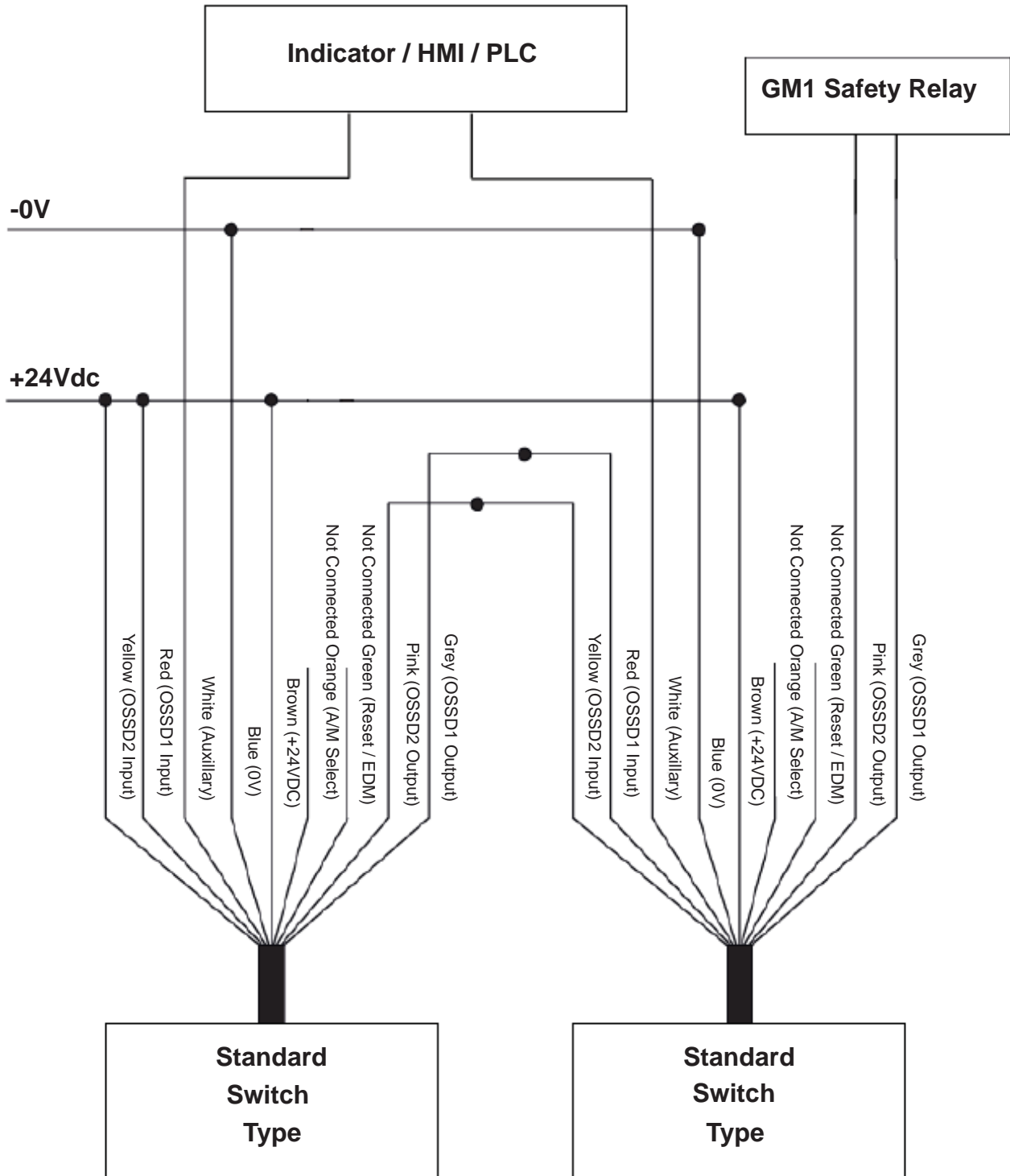

Typical connection example for ODNK, OSSG and OHE1

Wiring Example

Advanced series connection for ODNK, OHE1 and OSSG with EDM connection and cross monitoring

| | |
|-----------------------------------|------|
| Maximum Cable Length | 30 m |
| Maximum Number of Connected Units | 30 |

The contactors and relays must be force guided in order to safely monitor the external device.

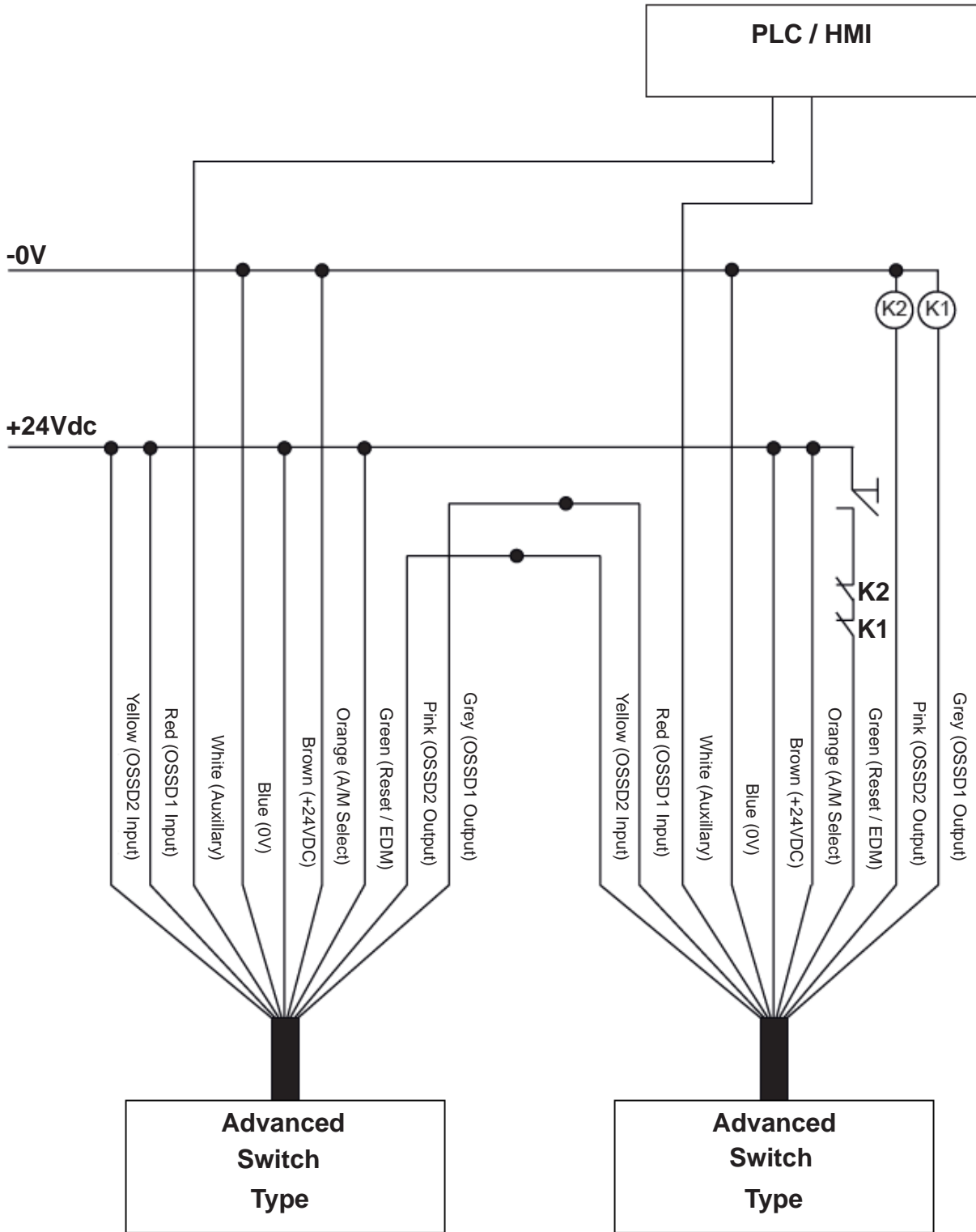

Advanced connection example for ODNK, OHE1 and OSSG with external device monitoring reset (EDM)

Note: The last switch is used to monitor the external device and control the reset function via a push button.

Indication

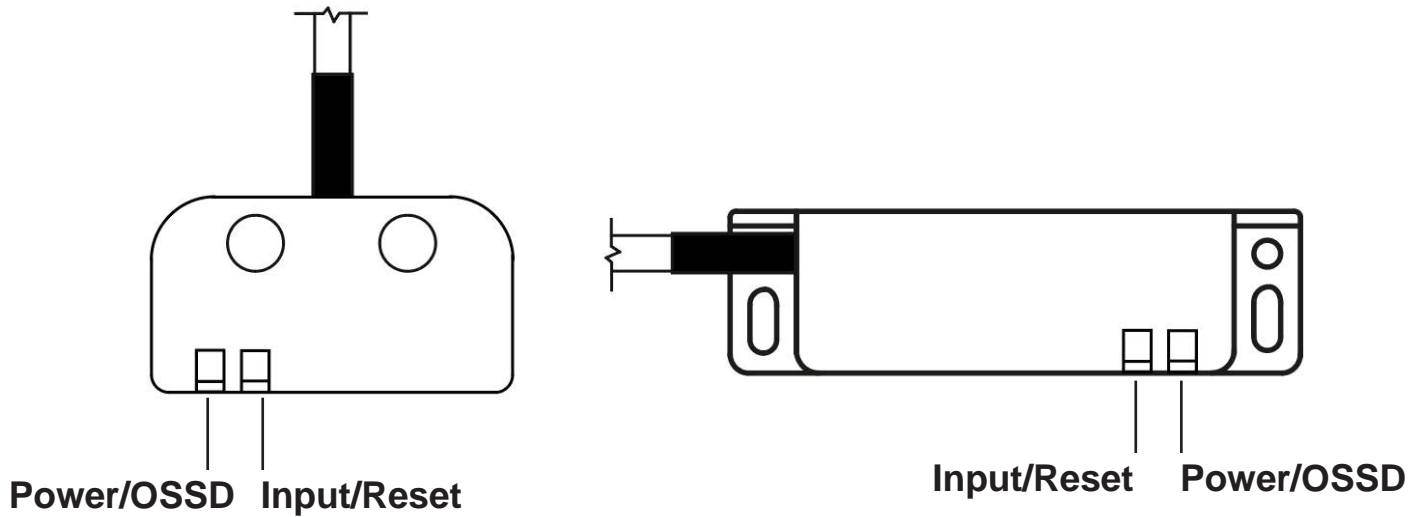

ODNK / OSSG LED Configuration

| Power/OSSD LED | Input/Reset LED | Description |
|-----------------|-----------------|--|
| | | No Power supplied to switch |
| Solid Red | | Power Supplied to switch, no actuator present |
| Flashing Red | | Output fault (turn power off and on to reset) |
| Flashing Red | Flashing Yellow | OSSD input fault (turn power off and on to reset) |
| Solid Green | | OSSD outputs are present and operating correctly |
| Flashing Green | Solid Yellow | Actuator present, OSSD inputs not detected |
| Flashing Green | Solid Blue | Actuator present, OSSD inputs present, external circuit needs resetting (EDM only) |
| Flashing Yellow | | No input, wrong actuator |
| | Solid Purple | Actuator has been taught |
| | Flashing Purple | No actuator present, voltage is at 17v ready to be taught |

OHE1 LED Configuration

| Power/OSSD LED | Input/Reset LED | Description |
|-----------------|-----------------|--|
| | | No Power supplied to switch |
| Solid Red | | Power Supplied to switch, no actuator present |
| Flashing Red | | Output fault (turn power off and on to reset) |
| Flashing Red | Flashing Yellow | OSSD input fault (turn power off and on to reset) |
| Solid Green | | OSSD outputs are present and operating correctly |
| Flashing Green | Solid Yellow | Actuator present, OSSD inputs not detected |
| Flashing Green | Solid Blue | Actuator present, OSSD inputs present, external circuit needs resetting (EDM only) |
| Flashing Yellow | | Actuator Misaligned to switch |

Solid Yellow (Input/Reset LED) Check previous connected safety switch is closed (operating) or check if inputs are connected correctly.

Flashing Yellow (Input/Reset LED) OSSD Input faults are due to different signals, one channel going high and the other low.

****-21-DC-EDM-03M

| | |
|---------|------------------|
| Version | |
| OHE1 | Coded Magnetic |
| ODNK | Unique Code RFID |
| OSSG | |

| | |
|----------------------|-----------|
| OSSD Safety Channels | |
| 2 | 2 Outputs |

| | |
|-------------------|--------------------|
| Signalling Output | |
| 1 | 1 Auxiliary Output |

| | |
|----------------|-------|
| Supply Voltage | |
| DC | 24Vdc |

| | |
|-----------------|----------------------------|
| Connection Type | |
| 03M | 3 Metre Pre-Wired |
| 06M | 6 Metre Pre-Wired |
| 10M | 10 Metre Pre-Wired |
| 5LQD | 5-Pin M12 150mm Leaded QD |
| 8LQD | 8-Pin M12 150mm Leaded QD |
| 12LQD | 12-Pin M12 150mm Leaded QD |

| | |
|----------|----------------------------|
| Function | |
| EDM | External Device Monitoring |

Example 1:

ODNK-21-DC-03M

Small type of O-Type housing

DC Voltage

Has 2 and 1 output contacts

3 Meter cable

Example 2:

OSSG-21-DC-EDM-03M

Large type of O-Type housing

DC Voltage

3 Meter cable

Has 2 and 1 output contacts

External device monitoring

Information

Safety Assessment

A risk assessment should take place to establish that the specifications of these safety switches are suitable for the application required. Please contact Mechan Controls for further information.

The products may only be installed, commissioned, operated, maintained by competent persons.

A competent person is a qualified and knowledgeable person who, because of their training, experience and current professional activity, has the specialist knowledge required. An understanding of European and International laws, directives and standards is recommended.

Maintenance

It is recommended to check the safe operation of the switches and look for signs of damage or excessive wear on a weekly basis. Damaged units should be replaced or returned to the manufacturer for repair where practical.

Disclaimer

In the interest of product development specifications are subject to change without notice. It is the responsibility of the user to ensure compliance with any acts or by-laws in place. All information regarding Mechan equipment is believed to be accurate at the time of printing. Responsibility cannot be accepted for errors or omissions.

Warranty

Warranty will be void if the following points are true:

- The product was not used for its intended purpose
- Damaged was caused by usage not stated in the manual
- Modifications have been made to the products (e.g exchanging components)
- Operating personnel are not suitably qualified
- Product is not fitted correctly according to install guide

Warning!



Removing the actuator from the guard may lead to loss of safety resulting in serious injury or death.

Security screws are provided with every O-Type safety switch.

M M E C H A N
..... C O N T R O L S