



**DATA SENSING**  
easing automation challenges



# Smart-VS

## AI-POWERED SMART SENSOR

AI-powered smart photoelectric sensor with machine learning algorithms. The smart solution for all presence, orientation and quality verification applications in industrial automation.

- No vision tool programming required
- No need of machine vision skills
- Deterministic response time
- Reduced cost of ownership and maintenance

- Electronic focus control
- Up to 400mm operating distance
- Bright and visible Red LED pointer
- Powerful white polarized light illuminator
- Green/Red LED Spot for GOOD/NO-GOOD part
- Ethernet TCP/IP communication
- Easy and Intuitive WEB Server GUI for maintenance and job setting



### CODE DESCRIPTION

**SMART-VS - MR - 5 - 150 - WH - 0 - AA**

series	<b>SMART-VS</b>	Smart-Vision sensor
type	<b>MR</b>	Metal housing radial optic STANDARD
	<b>PL</b>	Metal housing radial optic PLUS
	<b>EV</b>	Metal housing radial optic EVOLUTION
connection	<b>5</b>	M12 connectors Power I/O + Ethernet
	<b>6</b>	M12 8 pin connectors Power I/O + Ethernet
operating distance	<b>150</b>	Maximum operating distance 150 mm
	<b>400</b>	Maximum operating distance 400 mm
illuminator type	<b>WH</b>	Polarized white
output type	<b>0</b>	3 digital output
platform type	<b>AA</b>	Enhanced platform

# Smart-VS TECHNICAL SPECIFICATIONS

VISION SENSORS

	Smart-VS-MR-5-150-WH-0	Smart-VS-PL-5-150-WH-0	Smart-VS-EV-5-400-WH-0-AA
<b>GENERAL DATA</b>			
Operating principle	Object detection classification 2 classes	Object detection classification 3 classes	Object detection classification 6 classes + Anomaly detection
Imager	6 (total)	20 (total)	50 (total anomaly), 50 (total classifier)
<b>DETECTION CAPABILITIES</b>			
Nominal sensing distance	50 ... 150 mm	50 ... 400 mm	
<b>EMISSION DATA</b>			
Emission	LED white 4 polarized white H.P. LEDs + 2 LED red aim + 1 LED green spot + 1 LED green spot		
<b>FUNCTIONS</b>			
Sensitivity adjustment	TEACH-IN push button + WEB based GUI (through Ethernet)		
<b>INPUT/OUTPUT</b>			
Response time	0 ... 50 ms (deterministic)	15 ... 50 ms (deterministic)	15 ... 50 ms (deterministic classifier) 200 ms max (non det. anomaly)
Output type	3 NPN/PNP/PP, 1 Ethernet 10/100 (M12 8-pin X-coded)		4 NPN/PNP/PP, 1 Ethernet 10/100 (M12 8-pin X-coded)
<b>HMI/UI</b>			
LED indicators	6 LED yellow (output, run, trigger, good, bad, not used) + 2 on back (1 blue power, 1 yellow Ethernet)		
<b>ELECTRICAL DATA</b>			
Supply voltage	10 ... 30 Vdc		
Maximum residual ripple	1000%		
Leakage current	≤ 400 µA		
Maximum No-load absorption	0.14...0.4 mA@30V...10V (4W)		0.17...0.5 mA@30V...10V (5W)
Maximum DC output voltage drop	3 V @ IL=100mA		
Maximum DC load current	100 mA		
Short circuit protection	Yes		
Reverse polarity protection	Yes		
Impulsive overvoltage protections	Yes		
Protection to capacitive loads	Yes		
Insulation resistance	>20 MΩ 500 Vdc, between electronics and housing		
Ground resistivity	500 Vac 1 min., between electronics and housing		
<b>MECHANICAL DATA</b>			
Dimensions	47 x 58 x 38 mm Cubic		
Housing material	Aluminium / PMMA		
Active part material	PMMA		
Optical location	Radial 90°		
Weight	175.00 g Connector		
Connector material	Metal		
<b>CERTIFICATIONS</b>			
Certifications	CE, UKCA, CSA		
Electromagnetic compatibility	EN 60947-5-2		
<b>ENVIRONMENTAL DATA</b>			
Operating Temperature	0 ... 50 °C		
Mechanical Protection	IP67		
Storage temperature max.	-25 ... 70 °C		
Shocks and vibrations	0.5 mm amplitude, 10 ... 55 Hz frequency, for every axis (EN60068-2-6)		
Ambient light immunity	according to EN 60947-5-2 : 2020		

1 The embedded Ethernet interface is intended for configuration only through connection to the device IP. Point-to-Point connection is recommended.

2 High ambient temperature applications should use metal mounting bracket for heat dissipation.

3 When correctly connected (fully tightened) to IP67 cables with seals.

# AVAILABLE MODELS

Operating principle	Nominal sensing distance	Sensitivity adjustment	I/O	Connections	Output type	Model
Object detection classification 2 classes	50 ... 150 mm	TEACH-IN push button + WEB based GUI (through Ethernet)	3 Out + 2 In + ETH	M12 plug 17 pin	3 NPN/PNP/PP, 1 Ethernet 10/100 (M12 8-pin X-coded)	<b>Smart-VS-MR-5-150-WH-0</b> (959971320)
Object detection classification 3 classes	50 ... 400 mm					<b>Smart-VS-PL-5-150-WH-0</b> (959970005)
Object detection classification 6 classes + Anomaly detection			4 Out + 2 In + ETH	M12 plug 8 pin	4 NPN/PNP/PP, 1 Ethernet 10/100 (M12 8-pin X-coded)	<b>Smart-VS-EV-5-400-WH-0-AA</b> (959970009)

# RESPONSE DIAGRAMS

**Smart-VS-MR-5-150-WH-0 Inspection area**

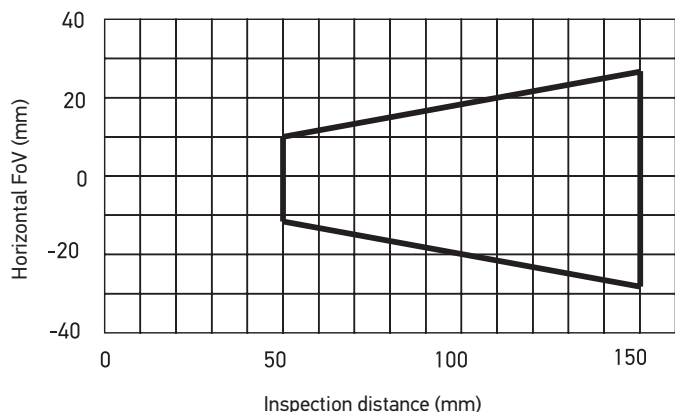

**SMART-VS-\*\*-5-\*\*\*-\*\*-0-\* Inspection area**

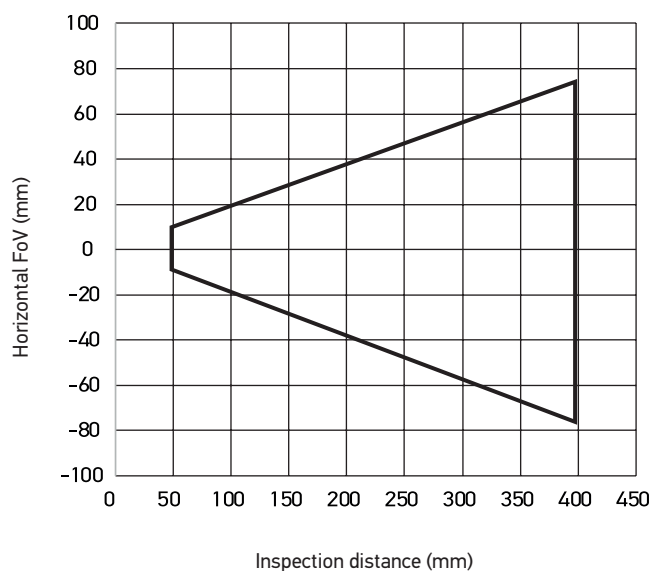

# CONNECTIONS

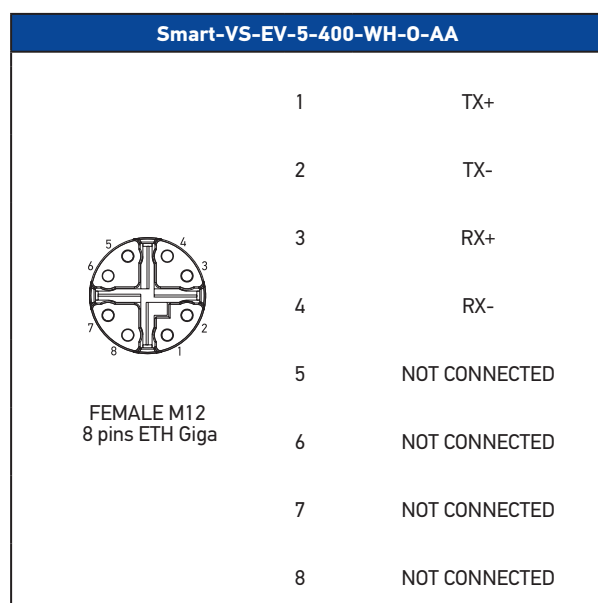
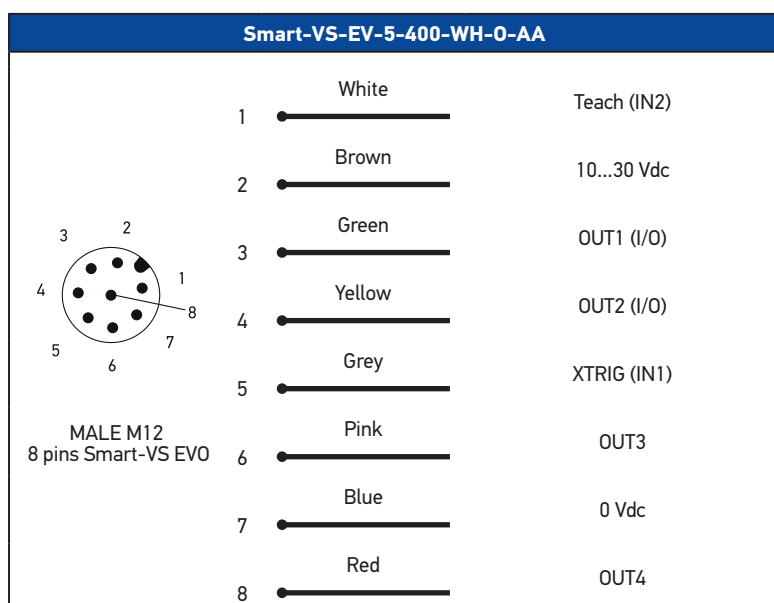

Smart-VS-**-5-150-WH-0		
1	Brown	+24 Vdc
2	Blue	0 Vdc
3	White	IN2-B REMOTE TEACH
4	Not Used	NOT CONNECTED
5	Pink	IN1-B TRIGGER INPUT
6	Yellow	IN1-A TRIGGER INPUT
7	Not Used	NOT CONNECTED
8	Gray	OUT GOOD PUSH PULL
9	Red	OUT DATA VALID PUSH PULL
10	Not Used	NOT CONNECTED
11	Not Used	NOT CONNECTED
12	Not Used	NOT CONNECTED
13	Green	IN2-A REMOTE TEACH
14	Not Used	NOT CONNECTED
15	Not Used	NOT CONNECTED
16	Black	OUT NO GOOD PUSH PULL

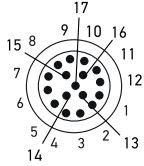

MALE M12  
17 pins Smart-VS  
Power I/O

\* The wire colors are referred to cables P/N 95A900052 and 95A900053

Smart-VS-**-5-150-WH-0		
1		TX+
2		TX-
3		RX+
4		RX-
5		NOT CONNECTED
6		NOT CONNECTED
7		NOT CONNECTED
8		NOT CONNECTED

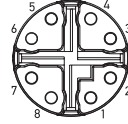

FEMALE M12  
8 pins ETH Giga

## INDICATORS AND SETTINGS



ITEM N.	DESCRIPTION
1	Illuminator with 4 powerful White LEDs with polaroid filter
2	7mm lens with automatic focus system
3	Aiming system with 2 powerful Red LEDs
4	Red Spot illuminator LED for NO GOOD detection object
5	Green Spot illuminator for GOOD detection object
6	2 holes for direct mounting or bracket
7	Blue Power Supply LED
8	Yellow Ethernet connection LED
9	M12 Ethernet X-coded female connector
10	Rotating connector block
11	M12-17 Pin Power Supply and I/O male connector
12	5 bright LED for User Interface signalization
13	Yellow TEACH-IN button for sensor set-up

# INDICATORS AND SETTINGS



## HMI CONFIGURATION



### NO GOOD object

- blinking: NO GOOD object teaching
- in Run phase: NO GOOD object detected



### For future use



### Trigger

- trigger received



### GOOD object

- blinking: GOOD object teaching
- in Run phase: GOOD object detected



### Run

- device in RUN phase

# MECHANICAL DRAWINGS

## Smart-VS-\*\*-5-\*\*\*-WH-\*\*

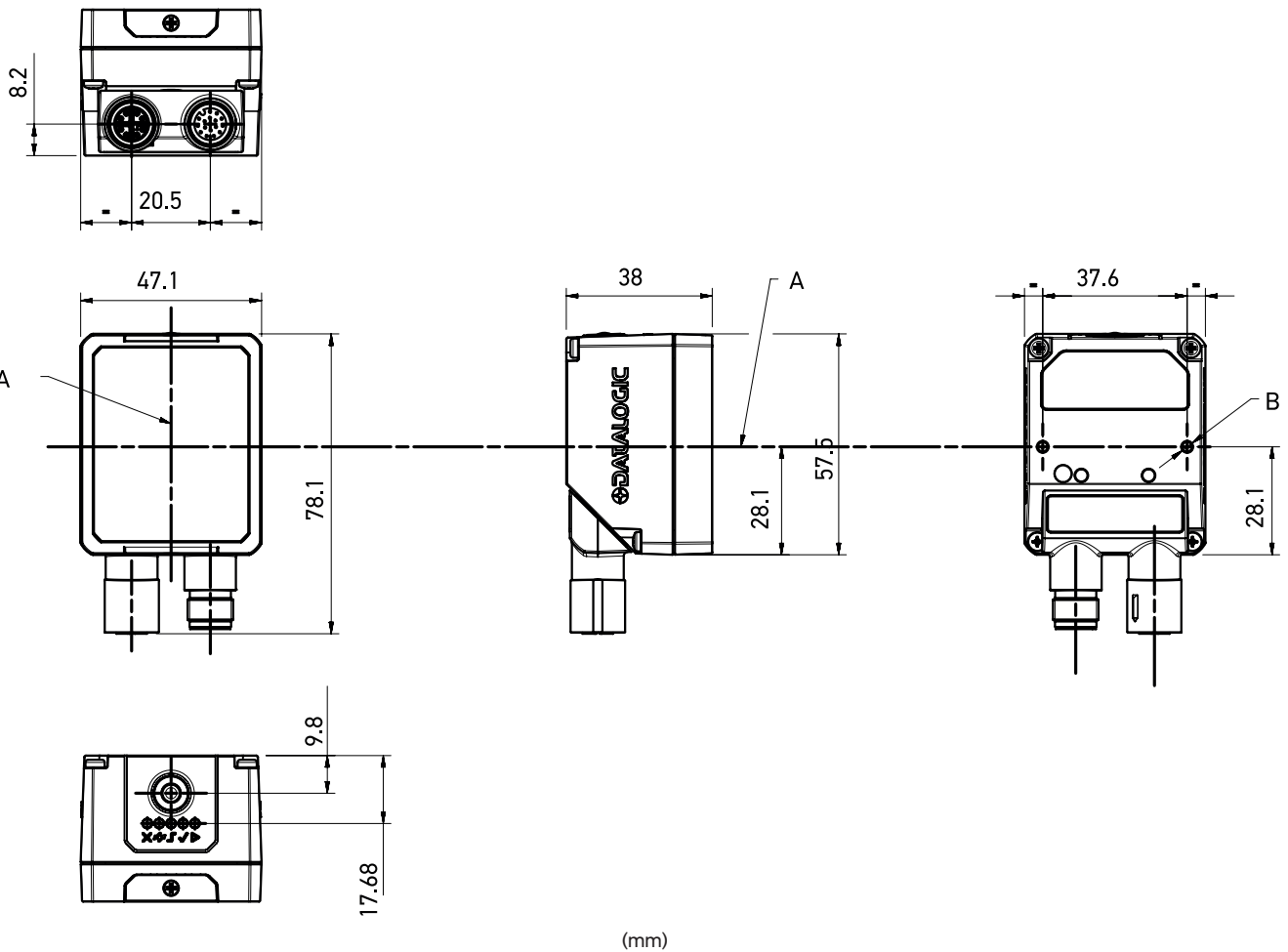

(mm)

Model	A	B
Smart-VS-**-5-***-WH-**	Optical Axis	M3 n°2 depth 4 mm

# Smart-VS FIELD OF VIEW Calculation

Use the data in the following table to calculate the FOV for your application, referring to the draw and the formula below.

$D_0$	View angle horizontal	View angle vertical	View angle diagonal	Min Reading Distance mm
11 mm	19°	14,5°	24°	50 mm

The viewing angle has a tolerance of  $\pm 1^\circ$  depending on the reading distance.

$$FOV_x = 2 [ (d + d_0) * \tan (\alpha/2) ]$$

where:

**FOV<sub>x</sub>** = horizontal, vertical or diagonal FOV

**$\alpha$**  = horizontal, vertical or diagonal viewing angles.

**d** = reading distance (in mm) from window surface to code surface

**$d_0$**  = offset (in mm) from center of lens to external window surface

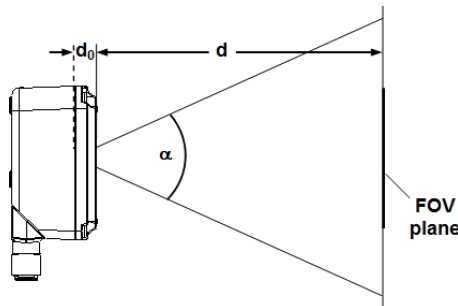

Example:

The FOV at a reading distance of 100 mm is:

$$FOV_H = 2[(100 \text{ mm} + 11 \text{ mm}) * \tan(19^\circ/2)] \cong 37 \text{ mm}$$

$$FOV_V = 2[(100 \text{ mm} + 11 \text{ mm}) * \tan(14,5^\circ/2)] \cong 28 \text{ mm}$$

## OPERATING PRINCIPLES AND APPLICATIONS

### Smart-VS simply clever

The Smart-VS is a Smart vision sensor simple and clever. It is simple outside since it can be handled and used like a standard photoelectric sensor but powerful and smart inside with a multiprocessor platform supporting and embedding the Artificial Intelligence technology. Its customized machine learning algorithms power the core of the detection system, enabling very complex and accurate object classification, while ensuring a very simple user setup procedure.

The user does not have to take care about programming or setting

threshold of different vision tools, all these complex functionalities are operated by the Smart-VS "brain".

The detection function is accomplished with three easy and fast steps: (1) GOOD condition teaching (2) NO-GOOD condition teaching (3) start learning and run! Ready to detect OK vs NG objects. All the user has to do is place the objects in front of the sensor and press the button to move through the configuration steps until the sensor starts to think and act.





The sensor is especially suited for all the applications where it is needed to solve detection between two well specified object condition classes, like presence or absence of a specific feature or object orientation respect two sides, teaching the sensor with OK vs NG condition.

This working principle makes the sensor setting easy and independent by the type, material, color of the object that needs to be detected.

Application name	Solved cases (OK / NOT OK)
Check label presence	
Cap orientation	
Cap presence	
Check printing on label	

# OPERATING PRINCIPLES AND APPLICATIONS

## Smart-VS simply clever

Application name	
Check label presence	
Cap orientation	
Cap presence	
Check printing on label	

The main application targeted for the best use of the Smart-VS is mainly related to print and apply where it is needed to detect presence or absence of labels or text printing.

Liquid filling machines where it is necessary to detect the presence/absence of any type of closure on any type of bottle, vial, flask, jar of any material, whether glass, plastic or with light/dark colored shiny/mat surfaces. Just make the sensor teach and learn the OK/NG condition and it will work. You do not need to set vision tools, sensitivity thresholds, image exposition, focus, sensor positioning or sensor sensitivity.

Bottling machines where it is needed to check if the label is present or not on the object making the sensor learning the presence/absence and then make it work immediately without additional settings, just pressing a push button or building up different recipes for different formats with an effective and easy WEB GUI interface.

## A great value for all the applications

The Smart-VS redefines the standards of detection eliminating all the concerns regarding the use of standard sensors about unstable detection or complex installation layouts to perform the presence/absence or orientation applications. A Smart-VS ensures:

- more stability in terms of different object materials and shape
- excellent stability on glass and metal parts
- easier system installation
- more flexibility and adaptability to different production formats
- easy setting avoiding more expensive and complex devices
- lower total cost of ownership and maintenance



## SMART-VS SETTING METHODS

### Easy and Comprehensive system integration

The Smart-VS is very easy and simple to integrate in any application, it can be implemented like a traditional sensor product, but it is much simpler than a smart camera or an ordinary smart sensor.

It is required to provide a trigger signal by machine electrical phase or an external simple sensor or encoder. The PC or Ethernet based terminal is an option needed to change configuration of the sensor or for more complex set-up where it is needed to change and/or add job setting through the web interface with a browser. The web interface can also be a useful tool in case of trouble shooting.

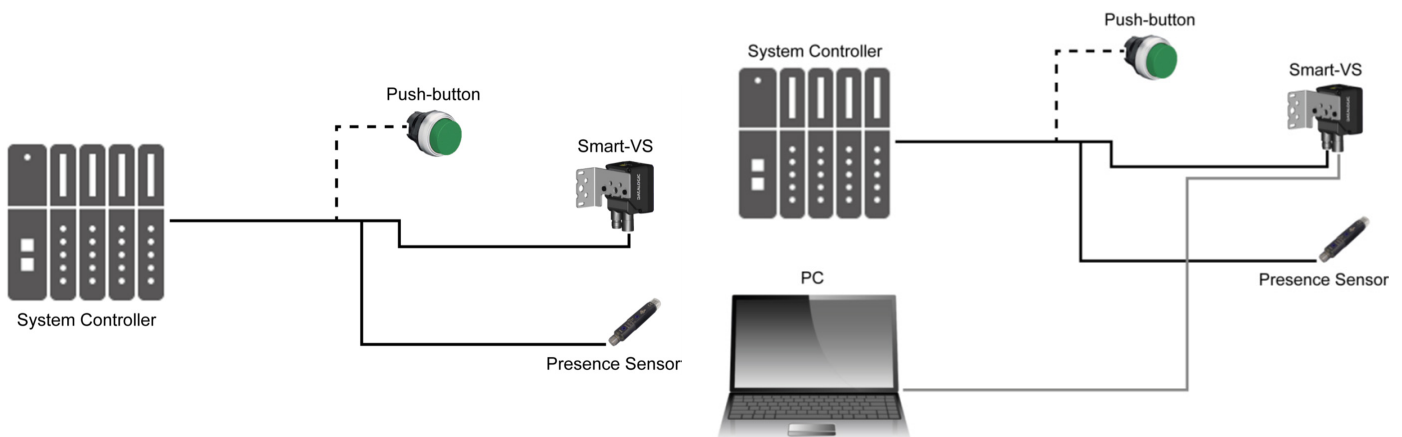

WEB INTERFACE  
SMART-VS-\*\*-5-150-\*\*-0

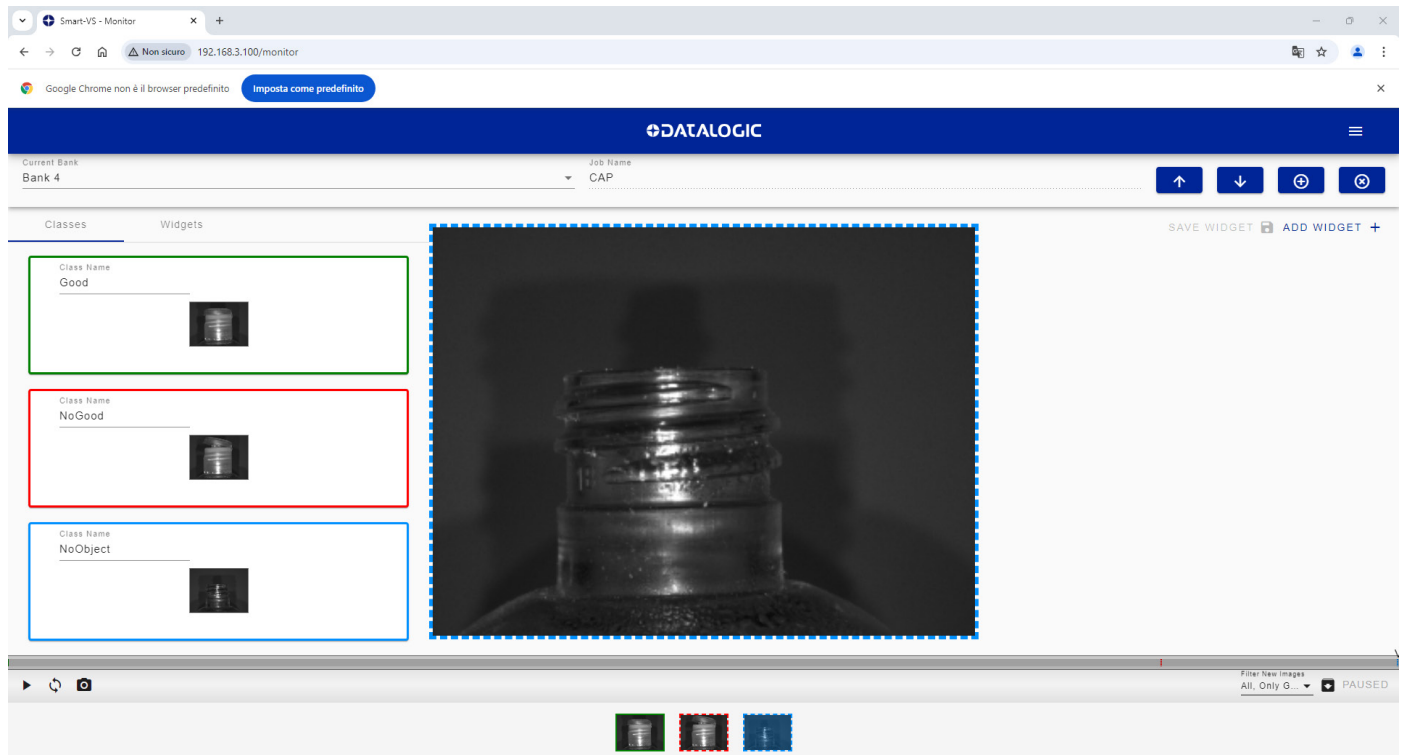
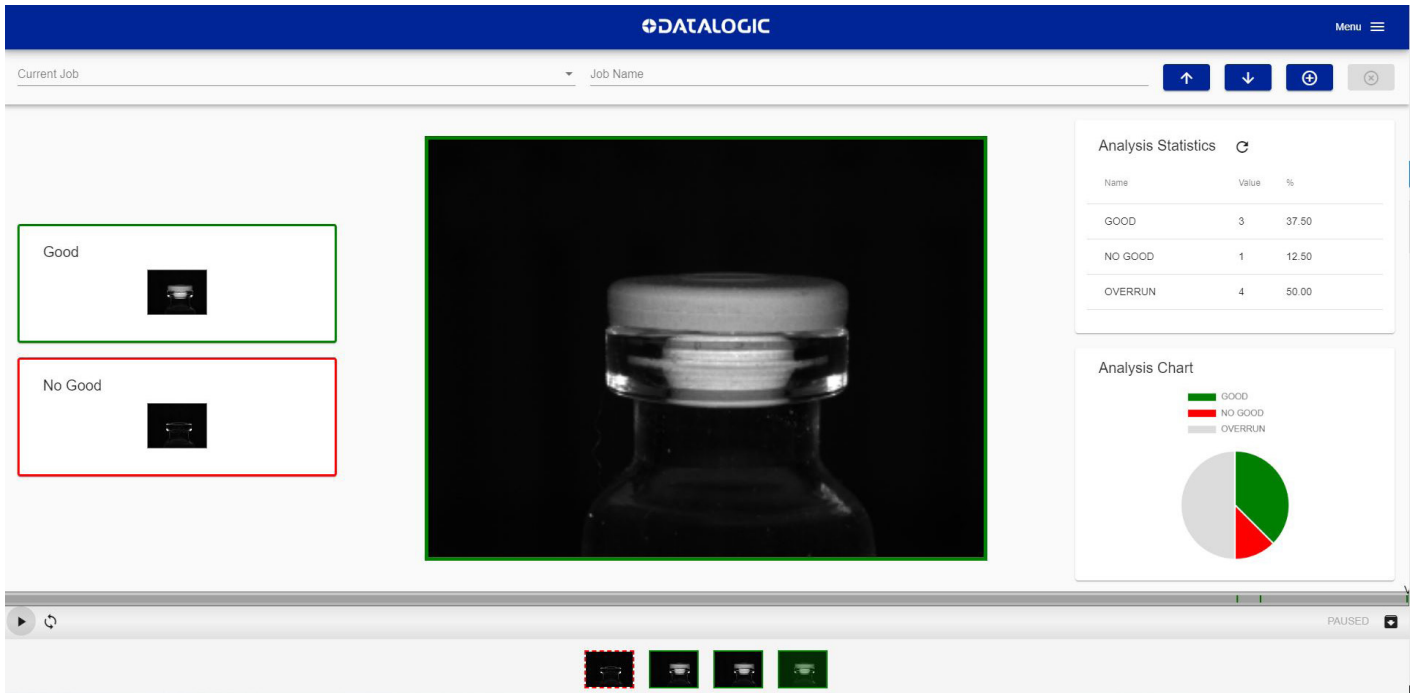

The Smart-VS is equipped with a WEB Server User interface for easy set-up and setting. This is an excellent tool when it is needed to setup and change different production configuration jobs depending on variable production format. The information are complete and shown in a clear layout.

# Smart-VS-EV-5-400-WH-0-AA ANOMALY DETECTION

☰
DATALOGIC

1 Image Setup
2 Select Inspection
3 Anomaly Detection
4 Learn



Anomaly Detection  
 Classification

### Anomaly Detection

GOOD



Learned

NO GOOD



Not Learned

Use **Anomaly Detection** when the good part is well known and defined and the no-good parts can have an unexpected or unknown status that can not be learned previously.

PREVIOUS
NEXT

Teach the OK object to detect any type of anomaly that may be present in the object for quality or integrity issues (NG).

# Smart-VS-EV-5-400-WH-0-AA CLASSIFICATION CLOSE SET

☰
DATALOGIC

1 Image Setup
2 Select Inspection
3 Classification Closed
4 Learn
5 Response Time



Anomaly Detection  
 Classification

### Classification

Open
  Closed

Object classification

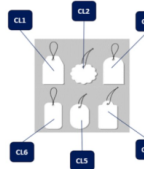

Classification of different «no good» status



Use **Classification** when the good and not parts are well known and defined or if you have to detect different object classes or different no-good type objects. **All the objects** that belong to good/no-good or different classes **must be learned** by the sensor. With the **Closed** set feature the sensor **does not give feedback for anomalies**, assigning in any case the detected object to one of the trained classes.

PREVIOUS
NEXT

Teach the sensor with all the objects that belong to all the different classes  
Closed set will assign in any case, the detected object, to one of the trained classes.

Smart-VS-EV-5-400-WH-0-AA  
CLASSIFICATION OPEN SET



- Anomaly Detection
- Classification

Classification

- Open
- Closed

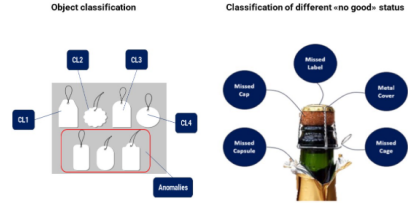

Use **Classification** when the good and not parts are well known and defined or if you have to detect different object classes or different no-good type objects. **All the objects** that belong to good/no-good or different classes **must be learned** by the sensor. With the **Open** set feature it is possible to get sensor **feedback for anomalies**, which is not referred to any of the trained classes.

PREVIOUS    NEXT

Teach the sensor with all the objects that belong to all the different classes  
Open set will find anomalies, which are not referred to any of the trained classes.

MANUALS

Smart-VS-**-5-**-WH-0-**-**		
806000510_SMART-VS_plus_prg_eng.pdf (4.02 Mb)	806000490_SMART-VS_PLUS_WebApp.pdf (1.43 Mb)	806000510_SMART-VS_plus_prg_ita.pdf (4.04 Mb)

SOFTWARE

Smart-VS-**-5-**-WH-0-**-**	
1.5.0.8_Package_For_SmartVS-Plus (22/08/2024). 1.5.0.8_Package_For_SVS-Plus.zip (22,36 Mb)	1.2.0_package for SMART-VS (22/08/2024) SMART-VS_1.2.0.zip

ACCESSORIES

	Model	Description	Article code
Cables	CS-A1-06-U-03	Cable M12 8 poles axial female unshielded 3m UL 2464	95ASE1220
	CS-A1-06-U-05	Cable M12 8 poles axial female unshielded 5m UL 2464	95ASE1230
	CAB-ETH-X-M01	CAB-ETH-X-M01 M12-IP67 GETH-X CAB 1 m	93A050122
	CAB-ETH-X-M03	CAB-ETH-X-M03 M12-IP67 GETH-X CAB 3 m	93A050123
	CAB-ETH-X-M05	CAB-ETH-X-M05 M12-IP67 GETH-X CAB 5 m	93A050124
	CAB-GD03	Cable, power and I/O for Smart-VS M12 17P 3 m stripped wires	95A900052
	CAB-GD05	Cable, power and I/O for Smart-VS M12 17P 5 m stripped wires	95A900053
Mounting brackets	BK-22-000	FIXING BRACKET M220 BODY	93A050230

The company endeavors to continuously improve and renew its products; for this reason the technical data and contents of this catalogue may undergo variations without prior notice. For correct installation and use, the company can guarantee only the data indicated in the instruction manual supplied with the products. Product and Company names and logos referenced may be either trademarks or registered trademarks of their respective companies. We reserve the right to make modifications and improvements. These products are NOT safety sensors and are NOT suitable for use in personnel safety application.