

Description

Operation mode and max sensing range:
 Thru-beam: 0-70 m
 Diffuse proximity: 0-5 m
 230 V ac, 115 V ac, 24 V ac or 24 V dc
 supply voltage

Manual sensitivity adjustment
Sensor LED-drive
Automatic sensor test
Adjustable on/off time delay
 1 relay and transistor output or 2 transistor outputs
Switch selectable light or dark function
Switch selectable long or short range
Power, output, sensor test and signal level indicators
11-pole DIN socket connection



The PA 11 is a 1-channel photoelectric amplifier, which is to be used in conjunction with a set of remote transmitter LT and receiver LR from the series 100, 110 and 120.

The microprocessor controlled sensor test ensures that the system will automatically detect and indicate a faulty transmitter or receiver – cable break or electrical failure – during operation, through the relevant LED located on the front panel. The sensor LED drive powers the optional monitor LEDs available on the remote sensors – output (LT) and power (LR).

This amplifier series offers manual sensitivity adjustment via integral potentiometers located on the front panel of the amplifier. Output can be

selected from either a relay and NPN or NPN and PNP transistor

outputs with or without a 0-10 sec on/off time delay. Light or dark function and

long or short range are switch selectable.

Technical Data		
Supply voltage		24 V dc, 24 V ac, 115 V ac or 230 V ac
Voltage tolerance		+/- 15 %
Current consumption		Max. 3,5 VA
Output	Relay	1 open / 1 close, 250 V ac / 3 A, 120 V ac / 5 A
	Transistor	60 mA / 30 V dc
Alarm output		-
Power on indicator		Green LED
Output indicator		Yellow LED
Signal level indicator		Green LED
LR receiver failure indicator		Red LED
LT transmitter failure indicator		Red LED
Sensor monitor LED drive		The green monitor LED on the receiver indicates 'Power ON' The yellow monitor LED on the transmitter indicates 'PA 11 output activated'
Hysteresis		Approx. 45 %
Operation frequency	Relay	14 Hz
	Transistor	20 Hz
Response time tON/ tOFF	Relay	35 ms / 35 ms
	Transistor	25 ms / 25 ms
Delay tON/ tOFF	PA 11 A	0-10 sec, adjustable
Housing material		Polycarbonate

Environmental Data		
Temperature, operation		-10 to +50 °C
Temperature, storage		-40 to +80 °C
Sealing class		IP 40
Approvals		a UK c RU US

Available Types

Model	Connection	Time Delay	Supply Voltage	24 V dc	24 V ac	115 V ac	230 V ac
			Output	Order Reference			
PA 11 A	11-pole DIN socket	On/Off delay	Relay and NPN	PA 11 A 303T	PA 11 A 302T	PA 11 A 301T	PA 11 A 300T
			NPN and PNP	PA 11 A 403T	PA 11 A 402T	PA 11 A 401T	PA 11 A 400T
-		Relay and NPN	PA 11 B 303T	PA 11 B 302T	PA 11 B 301T	PA 11 B 300T	
		NPN and PNP	PA 11 B 403T	PA 11 B 402T	PA 11 B 401T	PA 11 B 400T	

Note: Remote sensors and 11-pole DIN socket to be ordered separately.

Applicable Remote Sensors and Ranges

Series	Thru-beam	Diffuse Proximity
100 110 120	18 m	1,3 m
	40 m	2,7 m
	70 m	5,0 m

Wiring Diagrams

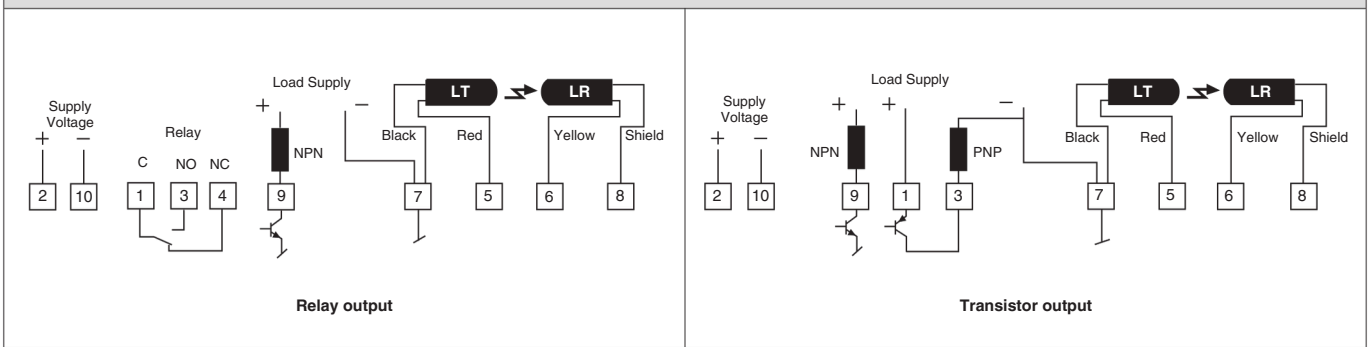

Dimensions and Descriptions

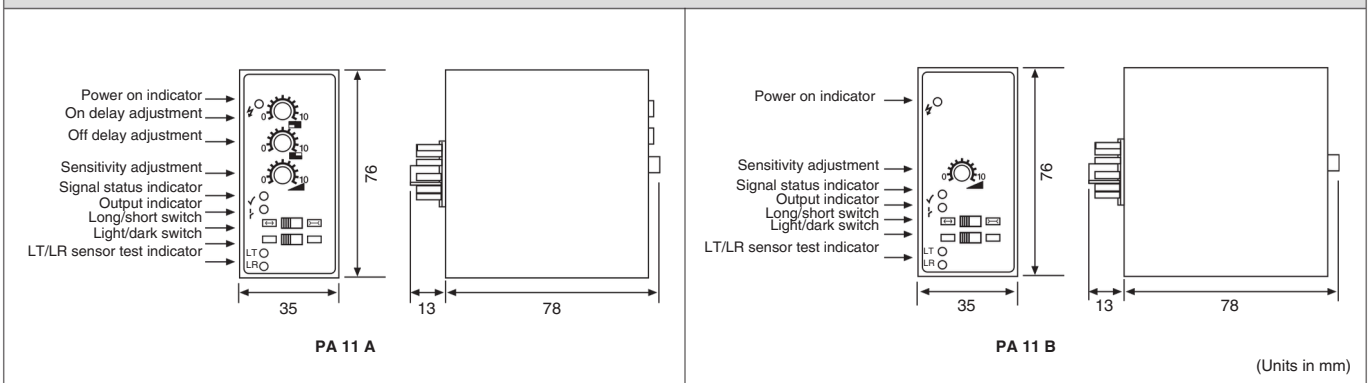

Telco reserves the right to change specifications without notice.

