



CONNECT AND PROTECT

Surge Protection Solutions

nVent ERICO Product Selection Guide



ERICO



Table of Content

The Need for Coordinated Protection.....	4	DT2 DIN Rail Surge Protection IEC Class II, 3+0 Mode.....	62
Facility Electrical Protection	6	DT2 DIN Rail Surge Protection IEC Class II, 4+0 Mode.....	63
nVent ERICO Expertise	8	DT2 DIN Rail Surge Protection Class II, 1+0 Mode, 100 kA....	64
Certified Surge Protection Devices	9	EDT2 Enhanced DIN Rail Surge Protection IEC Class II, 1+0 Mode	65
Transient Discriminating Technology	10	EDT2 Enhanced DIN Rail Surge Protection IEC Class II, 2+0 Mode	66
The Core of TD Technology	11	EDT2 Enhanced DIN Rail Surge Protection IEC Class II, 3+0 Mode	67
Selection and Application of AC Power System SPDs (IEC System).....	12	EDT2 Enhanced DIN Rail Surge Protection IEC Class II, 4+0 Mode	68
Selection and Application of AC Power System SPDs (IEC SYSTEM)	13	EDT2 Enhanced DIN Rail Surge Protection Class II, 1+0 Mode, 100 kA.....	69
Selection and Application of SPDs (AS 1768).....	14	PVT1 Photovoltaic Surge Protection Class I	70
A Guide to Common Power Distribution Systems.....	15	PVT2 Photovoltaic Surge Protection Class II.....	71
Selection and Application of AC Power System SPDs.....	16	Transient Discriminating Surge Diverter, 20 kA Three Mode.....	72
Data and Signal Line Protection.....	20	Surge Diverter, 24/48 DC	73
Products.....	23	Spark Gap Diverter, Type 1	74
Surge Protection Product Selection.....	25	Spark Gap Diverter, Type 2	75
SES 40P.....	28	DT2C Compact Surge Protection Class II, 1+1 Mode.....	76
SES 160/320/360/480 Series.....	29	DT2C Compact Surge Protection Class II, 2+0 Mode	77
Service Entrance Suppressor(B), 160 kA	30	Transient Surge Filter	78
Service Entrance Suppressor(F), 160 kA	31	Surge Reduction Filter N-Series, Single Phase.....	79
Service Entrance Suppressor(B), 320 kA.....	32	Surge Reduction Filter N-Series, Three Phase.....	80
Service Entrance Suppressor(F), 320 kA.....	33	High Speed Data Line Protector.....	81
Service Entrance Suppressor(BC), 320 kA	34	Subscriber Line Protector, Single Stage.....	82
Service Entrance Suppressor(FC), 320 kA.....	35	Telephone Line Protector.....	83
Service Entrance Suppressor(DB), 360 kA	36	Coaxial Surge Protector	84
Service Entrance Suppressor(DF), 360 kA	37	Closed Circuit Television Protector	85
Service Entrance Suppressor(DB), 480 kA.....	38	Ethernet and Power Over Ethernet Surge Protection	86
Service Entrance Suppressor(DF), 480 kA.....	39	LAN Surge Protector	87
SES Accessories	40	Data Equipment Protector.....	88
DT Panel Protector (B), 120 kA	41	Universal Transient Barrier, Single Pair.....	89
DT Panel Protector (F), 120 kA	42	Universal Transient Barrier, Dual Pair.....	90
DT Panel Protector, 120 kA, TT version.....	43	Universal Transient Barrier, Dual Pair Single Power.....	91
DT Panel Protector (B), 240 kA.....	44	Universal Transient Barrier, Single Pair Isolated Ground.....	92
DT Panel Protector (F), 240 kA.....	45	Universal Transient Barrier, Modem/Telephone.....	93
DT Panel Protector, 240 kA, TT Version	46	RTBN Rail Transient Barrier	94
Compact TDX Panel Protector, 50 kA.....	47	Remote Transmitter Protector.....	95
TDXM Modular Series	48	Load Cell Protector	96
DT and EDT SPD Features.....	54	Surge Counter, Digital Display	97
DT1M Din Rail Surge Protection Class I+II 25 kA	55	Potential Equalization Clamp.....	98
DT1 DIN Rail Surge Protection IEC Class I+II, 1+0 Mode.....	56	MOV/GDT/SAD Tester MGATESTER1	99
DT1 DIN Rail Surge Protection IEC Class I+II, 2+0 Mode.....	57	Glossary of Terminology.....	100
DT1 DIN Rail Surge Protection IEC Class I+II, 3+0 Mode.....	58		
DT1 DIN Rail Surge Protection IEC Class I+II, 4+0 Mode.....	59		
DT2 DIN Rail Surge Protection IEC Class II, 1+0 Mode	60		
DT2 DIN Rail Surge Protection IEC Class II, 2+0 Mode	61		

NOTE: Product application information given in this document is of a general nature. Installers of the product are cautioned to ensure product is always installed in accordance with any applicable National Standards, Codes, and Practices.

The Need for Coordinated Protection



CRITICAL FACTORS

Critical factors need to be considered when determining the need for facility protection. Many factors can be determined by answering the following questions:

- What is the risk to personnel?
- What is the risk of equipment damage?
- What are the consequences of equipment failure?
- Is the equipment associated with an essential service?
- How will equipment failure affect overall facility operation and revenue generation?
- What are the legal implications of providing inadequate protection?

The statistical nature of lightning and the broad spectrum of energy delivered by a lightning flash, the problems created by various power generation and distribution systems, and the continued trend to more sensitive and specialized electronics, requires careful selection of available technologies if adequate protection is to be provided.

WHAT ARE THE COSTS OF INADEQUATE PROTECTION?

The costs that can result from inadequate protection are many and varied. The type of equipment within a facility will have a direct impact on the damage that can occur. Robust equipment, such as lightning and air-conditioning systems, are often able to withstand impulses as high as 1500 volts and are not as sensitive to the rapid rate-of-rise exhibited by the pre-clamped surge waveform as are electronics.

These systems are often not critical to the continuing operation of the site and therefore usually do not require the premium level of protection that is essential for more sensitive equipment. However, significant damage

can occur, even to the more robust systems, as a result of lightning induced surges resulting within a radius of several kilometers, or from switching induced surges. Costs can range from degradation of electrical or electronic systems to data loss, equipment destruction or injury to personnel. Some of these costs can appear relatively minor but the loss of an essential service or revenues associated with a facility or plant shut down can be enormous.

SOURCES OF TRANSIENTS AND SURGES

Although lightning is the most spectacular form of externally generated surges, it is only one source of over-voltage. Other sources include the switching of power circuits, the operation of electrical equipment by neighboring industries, the operation of power factor correction devices, and the switching and clearing of faults on transmission lines. It is

important to note that lightning does not need to directly strike a power line for such damage to occur; a strike several hundred meters away can induce large damaging transients, even to underground cables.

It is estimated that 70 to 85% of all transients are generated internally within one's own facility by the switching of electrical loads such as lights, heating systems, motors and the operation of office equipment.

Modern industry is highly reliant on electronic equipment and automation to increase productivity and safety. The economic benefits of such devices are well accepted. Computers are commonplace and microprocessor-based controllers are used in most manufacturing facilities. Microprocessors can also be found embedded in many industrial machines, security & fire alarms, time clocks and inventory tracking tools. Given the wide range of transient sources and the potential cost of disruption, the initial installed cost of surge protection can readily be justified for any facility.

As a guide, the cost of protection should be approximately 10% of the cost of the facility's economic risk.

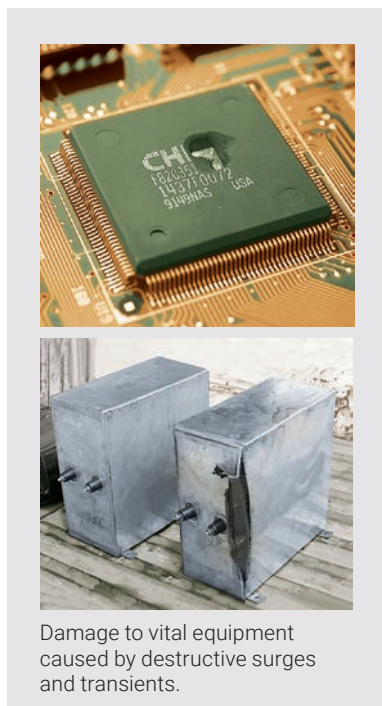

Damage to vital equipment caused by destructive surges and transients.

The Need for Coordinated Protection

Reliable protection of structures, industrial and commercial operations and personnel, demands a systematic and comprehensive approach to minimize the threats caused by transient over-voltages. Grounding, bonding, lightning protection and surge protection all need to be considered for comprehensive facility electrical protection. Each of these are interdependent disciplines that need a holistic design approach to ensure the facility is not left with a vulnerable "blind spot". The investment in surge protection can be wasted if "blind spots" exist. For example, installing a surge protection device on the power supply to a programmable logic controller is of little value if the I/O lines are not also protected. In addition, an air terminal on the facility may capture the lightning energy but without a dependable ground system, this energy cannot be safely dissipated.

Equally, even the most expensive Surge Protection Devices (SPDs) are poor performers if a low impedance equipotential ground is not provided. These interdependent disciplines are best applied when looking at a total facility rather than at an individual piece of equipment or portion of the facility.

It is for these reasons that the nVent ERICO Electrical Plan of Protection was created. The plan prompts the consideration of a coordinated approach to lightning protection, surge and transient protection and grounding, an approach that embraces all aspects of potential damage, from the more obvious direct strike to the more subtle mechanisms of differential earth potential rises and voltage induction at service entry points.

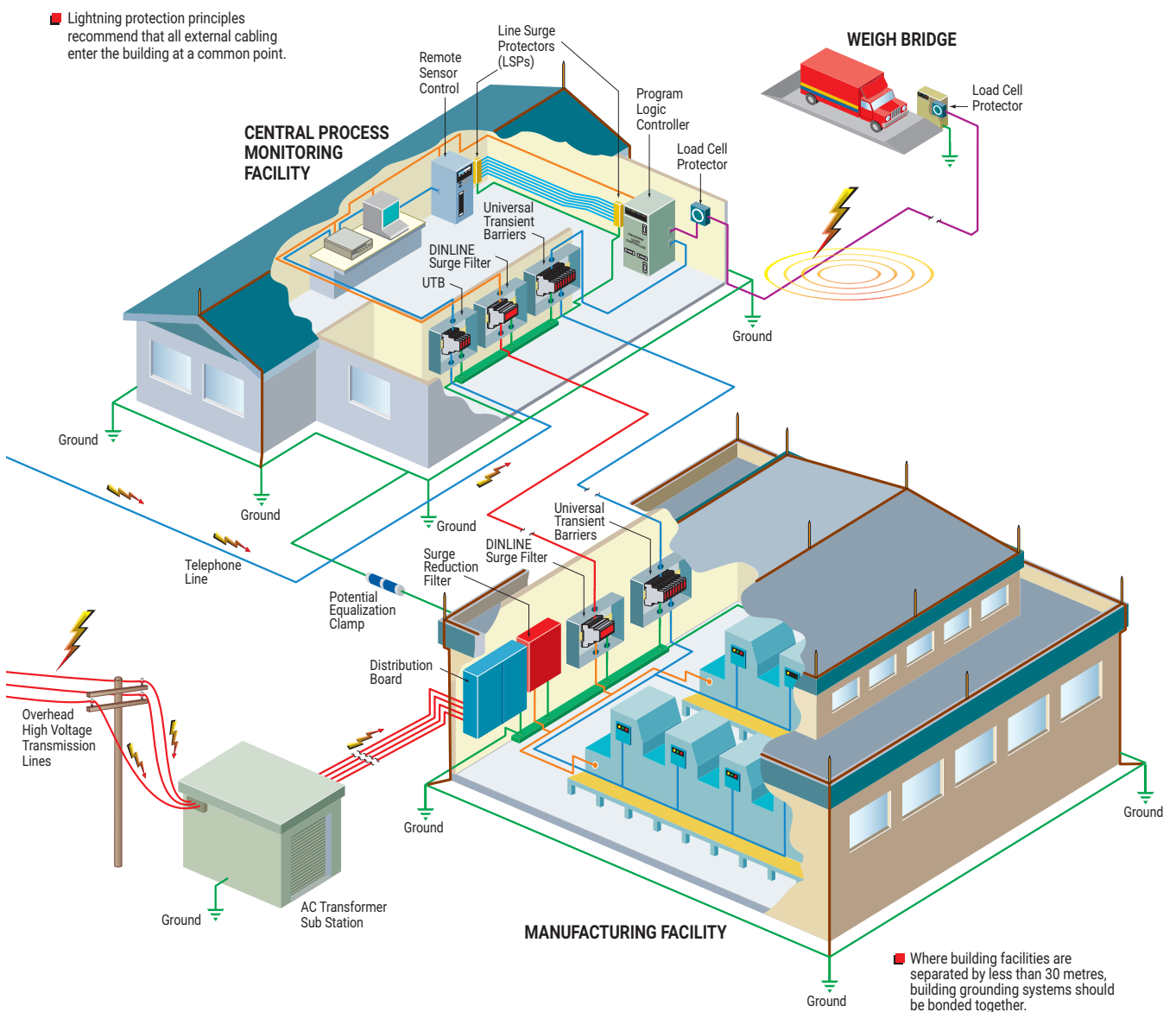

nVent ERICO Electrical Plan of Protection applied to a manufacturing facility. Surge and transient protection principles applied to an entire facility rather than individual pieces of equipment.

Facility Electrical Protection

NVENT ERICO ELECTRICAL PLAN OF PROTECTION

Lightning strikes and the dangerous over-voltage surges caused by lightning and man-made events represent a direct threat to people, buildings and sensitive electronic equipment.

Today, the consequences of an unexpected lightning strike or power surge can be catastrophic for a business. Proper protection can save thousands of dollars in damage, operational downtime and lost business opportunities.

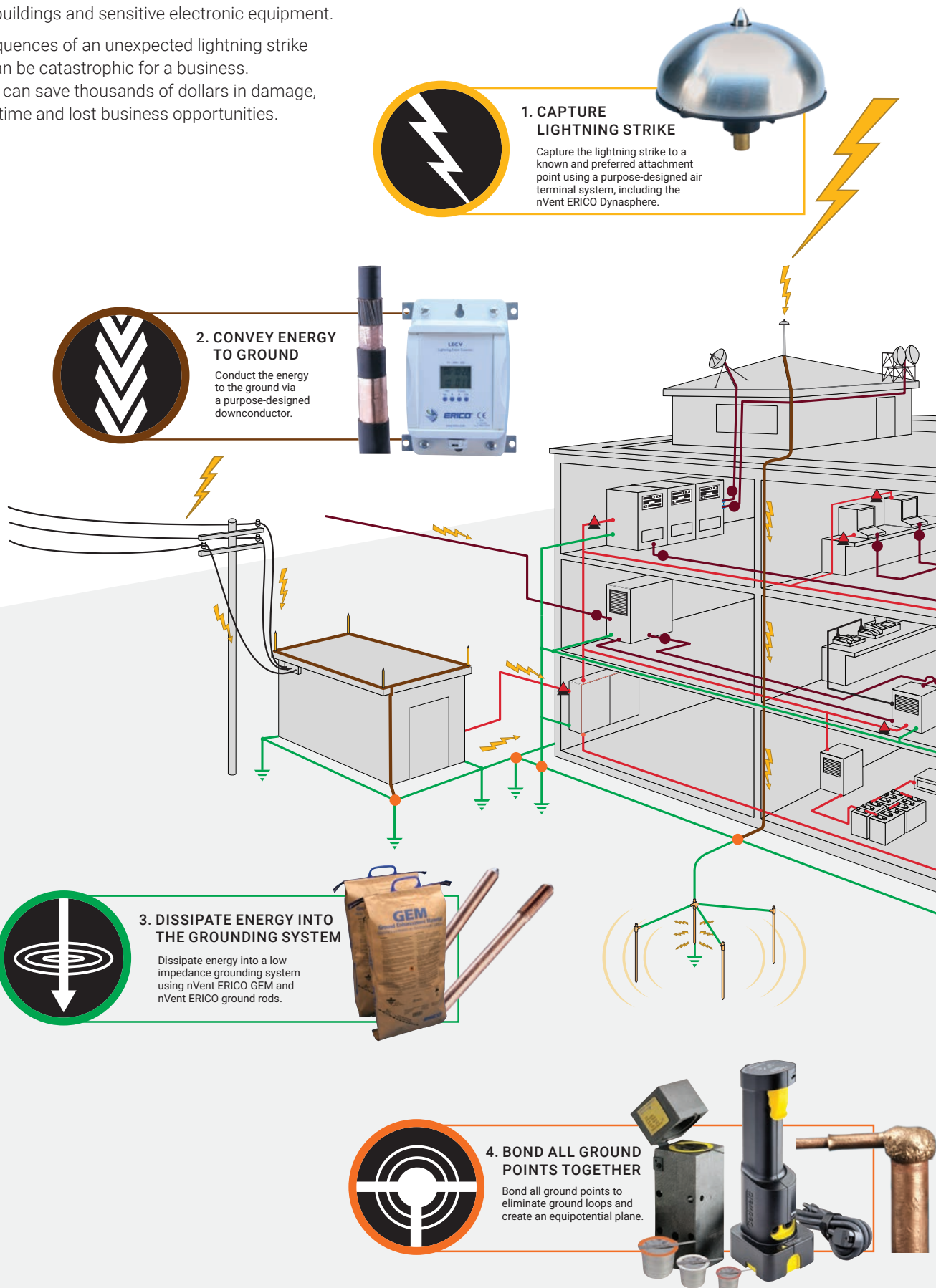

1. CAPTURE LIGHTNING STRIKE

Capture the lightning strike to a known and preferred attachment point using a purpose-designed air terminal system, including the nVent ERICO Dynasphere.



2. CONVEY ENERGY TO GROUND

Conduct the energy to the ground via a purpose-designed downconductor.



3. DISSIPATE ENERGY INTO THE GROUNDING SYSTEM

Dissipate energy into a low impedance grounding system using nVent ERICO GEM and nVent ERICO ground rods.



4. BOND ALL GROUND POINTS TOGETHER

Bond all ground points to eliminate ground loops and create an equipotential plane.



FACILITY PROTECTION

The consequences of an unexpected lightning strike or power surge can be catastrophic for a facility:

- Personnel are at risk
- Critical equipment may be damaged or destroyed
- Data can be corrupted
- The costs of operational downtime and lost revenue can be very substantial

As industries become more dependent on increasingly sensitive equipment, proper protection from lightning and dangerous over-voltage transients is necessary. With more than a century of research, testing and product development, nVent ERICO has acknowledged that no single technology can totally eliminate vulnerability to lightning and surges.

The nVent ERICO Electrical Plan of Protection is designed to provide facility protection by integrating several concepts.

The nVent Electrical Plan of Protection will minimize the risk of damage to facilities through:

- Direct lightning strike protection
- Grounding and bonding
- Surge and over-voltage transient protection

ABOUT NVENT ERICO

For more than 100 years, nVent ERICO has been an essential supplier of electrical protection for critical infrastructure around the world. Our engineered solutions, application expertise and quality products provide protection from the ground up through grounding and bonding, surge protection and lightning protection.



6. PROTECT LOW VOLTAGE DATA/ TELECOMMUNICATIONS CIRCUITS

Protect equipment from surges and transients on incoming telecommunications and signal lines to prevent equipment damage and costly operational downtime.

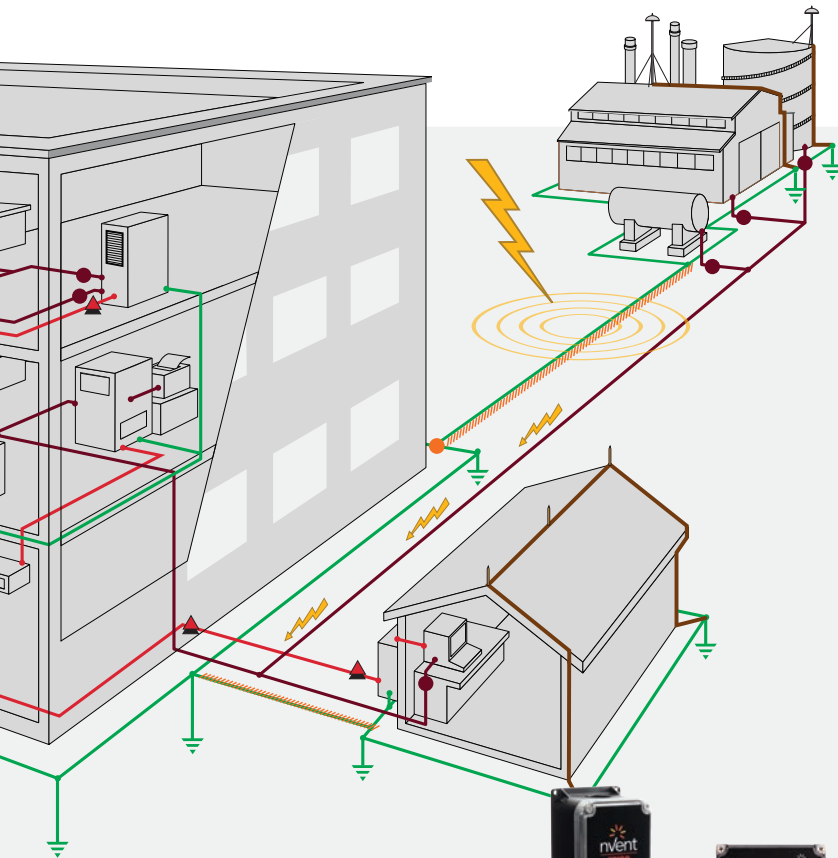
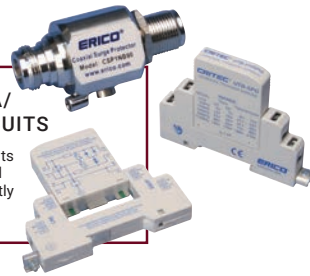

5. PROTECT INCOMING AC POWER FEEDERS

Protect equipment from surges and transients on incoming power lines to prevent equipment damage and costly operational downtime.



nVent ERICO Expertise

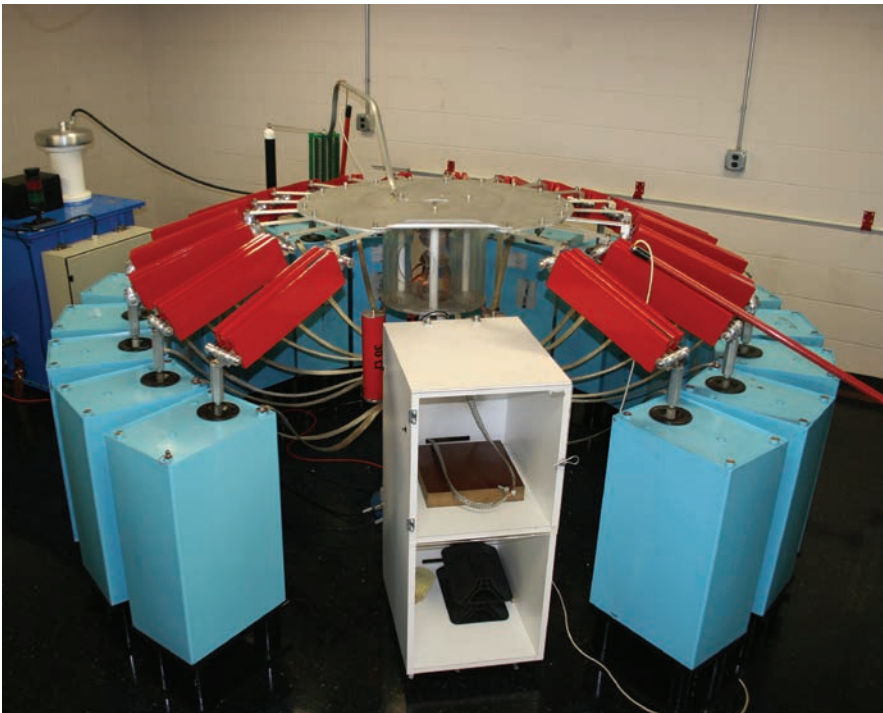

The nVent ERICO advantage is our approach to the complete Facility Electrical Protection Solution. Well designed and high quality surge protection is critical to a facility equipment's reliable operation, however it is only part of the solution.

nVent ERICO therefore offers the complete range and expertise in grounding, bonding, surge and lightning protection, providing the complete solution worldwide and across applications including Commercial, Industrial, Telecom, Utility and Railway. Our service and expertise encompasses more than just the product.

PRODUCT TESTING

To effectively meet market requirements and ensure our products are designed and tested to the highest of performance standards, nVent ERICO has invested in state of the art testing equipment that is able to:

- Support application testing for clients – to ensure your equipment is adequately protected.
- Participate in the UL Client Test Data Program.
- Support competitive product testing.
- Test and evaluate to a range of mechanical, electrical and environmental requirements.

HISTORY

nVent ERICO continues to be a pioneer in the low voltage surge protection industry, having been involved in grounding and bonding applications for over 100 years, and as a manufacturer of surge protective devices for over thirty years.

Our involvement in the industry predates the creation of the initial IEC and UL low voltage surge protection standards. We've been on the journey since the early days of Low Voltage AC surge protection, with the issuing of the IEEE587 standard in 1980, and we have been active on all major worldwide SPD standards committees and industry bodies (including IEEE, IEC, and UL)



since.

SEMINARS AND SITE AUDITS

Each year nVent ERICO conducts hundreds of seminars in numerous countries around the world, educating specifiers, engineers, and installers on Facility Electrical Protection, of which surge protection plays a key role.

Certified Surge Protection Devices



nVent ERICO surge protective devices (SPDs) provide the option for traditional construction or Transient Discriminating (TD) technology. For example, the DT product line features traditional construction, while the EDT product line features with TD technology. These product lines have been designed and independently tested and certified to the latest editions of both IEC 61643-11 and UL 1449

This provides the user of the product peace of mind that the products will perform safely in application, and also perform to the claimed ratings provided. Both these standards have stringent tests that are not easy to pass, but essential to ensure the product is designed well for safe behavior, and for effective protection performance to the product ratings.

Compliance to these standards are required by code in many countries, however still many countries around the world do not require compliance, leaving those countries vulnerable to poorly performing products.

An informed buyer will avoid non-compliant product, instead demanding compliance to one or both of these standards, factually verified by an independent third party test laboratory certificate. Compliance to these standards alone however should be



considered a benchmark or minimum requirement, as there are certain enhanced performance requirements that may be advantageous for some applications.

One example of this is how the SPD performs during an AC overvoltage event. In both standards referenced

above, the requirement is for the SPD to safely disconnect from service during these events, however a better solution is for the SPD to survive such an event, thereby continuing to provide protection to your valuable equipment being protected.

nVent ERICO's TD technology delivers just that, a true step-up in performance for SPDs. Our SPDs with TD technology have been designed to be unaffected by the AC overvoltages applied during testing, while not compromising the clamping performance. This provides them with the ability to survive extreme overvoltage conditions and still be operational afterwards to protect your valuable equipment from subsequent surges and transients.

This extends greatly the life expectancy of the SPD within the most extreme environments, saving maintenance work and reducing operational downtime.

Transient Discriminating Technology

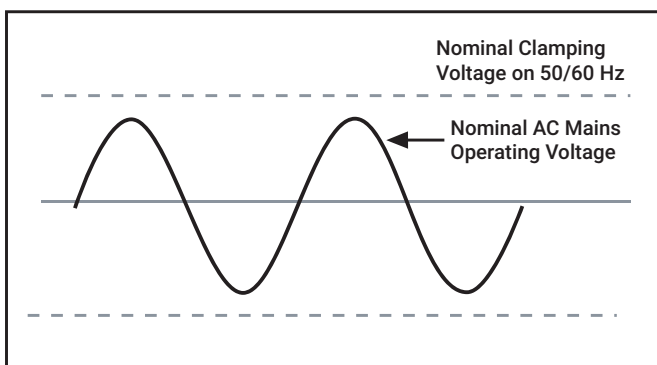

To meet the fundamental requirements of performance, longer service life and greater safety under real world conditions, nVent ERICO has developed Transient Discriminating (TD) Technology.

This quantum leap in technology adds a level of “intelligence” to the surge protection device enabling it to discriminate between sustained abnormal overvoltage conditions (Temporary Over Voltages – TOVs) and true transient or surge events. Not only does this help ensure safe operation under practical application, but it also prolongs the life of the protector since permanent disconnects are not required as a means of achieving internal over-voltage protection.

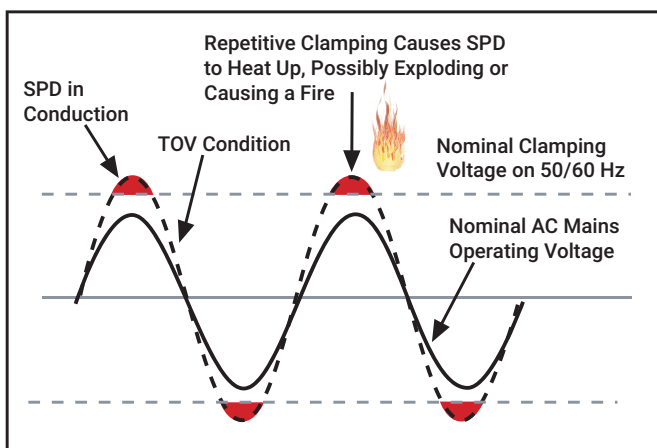

TRADITIONAL TECHNOLOGIES

Conventional SPD technologies utilizing metal oxide varistors and/or silicon avalanche diodes to clamp or limit transient events are susceptible to sustained 50/60 Hz mains over-voltage conditions (TOVs) which often occur during faults to the utility system. Such occurrences present a significant safety hazard when the suppression device attempts to clamp the peak of each half cycle on the mains overvoltage.

This condition can cause the device to rapidly accumulate heat and in turn fail with the possibility of inducing a fire hazard. The diagram shows how a traditional SPD is chosen to have a nominal clamping voltage that is above the peak of the nominal AC mains voltage. However, in the lower diagram, it can be seen that when the AC mains experiences a Temporary Over-Voltage (TOV), the SPD attempts to clamp the over-voltage, and rapidly heats up, resulting in failure, potentially accompanied by fire or explosion.

The Core of TD Technology



The secret to nVent ERICO's Transient Discriminating Technology is its active frequency discrimination circuit. This patented device can discriminate between a temporary over-voltage (TOV) condition and a very fast transient, which is associated with lightning or switching-induced surges. When the transient frequencies are detected, the patented Quick-Switch within TD activates to allow the robust protection to limit the incoming transient. The frequency discriminating circuit that controls the Quick-Switch helps ensure that the SPD device is immune to the effects of a sustained 50 or 60 Hz TOV. This allows the device to keep operating, in order to help provide safe and reliable transient protection, even after an abnormal over-voltage condition has occurred.

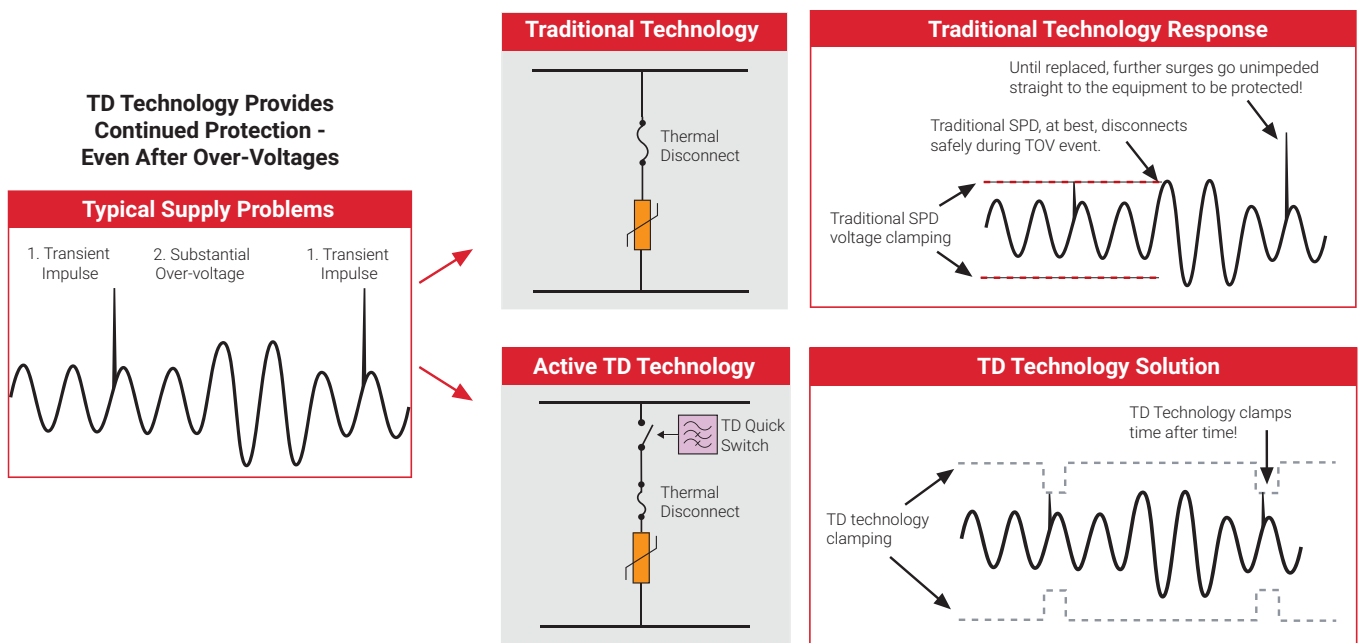

Effectively, TD Technology allows the SPD to have two clamping levels – one well above the peak of a TOV (up to twice its nominal AC voltage!), and the other much lower, to effectively and swiftly clamp lightning transients.

As the explanatory illustration shows, this allows the TD circuit to still remain operational after TOV events, thus continuing to clamp transients and providing a much longer operational life. For example, the IEC 61643-11 standard applies a test of 442 Vac for two hours from Line to Neutral for SPDs intended to operate at 230 Vac. While most SPDs fail safely during this test, nVent ERICO's EDT2 Series SPDs are unaffected by this stringent test, and remain completely operational. The IEC 61643-11 standard calls this Withstand mode, as opposed to Safe Failure mode.

nVent ERICO SPDs that incorporate TD Technology are especially recommended for any site where sustained over-voltages are known to occur, and where failure of traditional SPD technologies cannot be tolerated.

Selection and Application of AC Power System SPDs (IEC System)

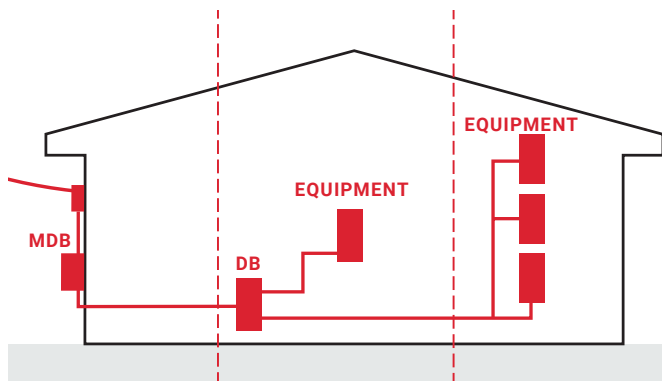

CLASS OF SPD

In the IEC system, SPDs are tested to various Test Classes, intended to assess and assure their suitability for use in different locations and circumstances. Strictly speaking, the Class refers to the type of test, not to the SPD. However, in common usage, SPDs are referred to by their Class, for example, a Class I SPD is an SPD that has been tested to Class I requirements (of a specified severity), and so on.

The Test Classes are as follows:

Class I – Tested with simulated partial conducted lightning current impulses. These SPDs would be used at points of high exposure, such as where the line close to the SPD might be directly struck by lightning, or at the point of entry to a building fitted with a direct strike Lightning Protection System (LPS).

Class II – Tested with shorter duration current impulses. These SPDs would be installed where the surge currents are expected to be less. This could be at the main power entry point of a building in a non-exposed location (surrounded by taller buildings, for example), or at sub-panels within the building.

Class III – Tested with voltage impulses. These SPDs would be installed at equipment to be protected, and are only expected to handle residual voltages surges that “got past” upstream Class I or II SPDs, and the associated small surge currents. Often, for convenience, Class II protectors are used at these locations as well.

In the illustration above, the type of SPDs installed at the Main Distribution Board, Distribution Boards, and the Equipment to be protected would be as follows:

Building Situation	MDB	DB	Equipment
Highly exposed, or fitted with LPS	Class I	Class II	Class III (or II)
Less exposed, no LPS	Class II	Class II	Class III (or II)

There are a number of IEC standards that work together to provide a system of classifying the power system, the over-voltages that can occur at different points in the system, the performance and application of SPDs, and the relative susceptibility of end use equipment to lightning surges. The most directly relevant are the IEC 62305 series standards dealing with both lightning protection and surge protection, and the IEC 61643 series standards covering testing, selection, and application of SPDs.

Fitting SPDs at all three locations may not be necessary, depending on the building size, and wiring length. Generally, SPDs are always fitted at the point of entry, and in smaller equipment rooms may just be, additionally, at the equipment. In larger buildings, spread over multiple floors or large areas, SPDs would usually be provided at the distribution boards, and additionally at sensitive or critical equipment.

SPDs are primarily rated according to how large a surge current magnitude they can handle, and how well they limit the voltage while conducting that surge current. These parameters are

Test Class	Parameter	Description
Class I	Impulse Current, I_{imp}	This current impulse has a 10/350 μ s waveform.
Class II	Nominal Discharge Current, I_n	This current impulse has a waveform of 8/20 μ s, and is nominal because the SPD has to successfully handle a sequence of 15 of these impulses.
	Maximum Discharge Current, I_{max}	This current impulse has a waveform of 8/20 μ s, and is the maximum 8/20 μ s impulse the SPD can handle. It is an optional parameter.
Class III	Open circuit voltage of the combination wave generator, U_{oc}	
All Classes	Voltage Protection Level, U_P	

It is possible to test one SPD type at more than one Test Class. SPDs are marked and specified with the parameters they have been successfully tested to.

Selection and Application of AC Power System SPDs (IEC SYSTEM)

RECOMMENDED SURGE RATINGS (8/20 μs)

ANSI/IEEE C62.41			CAT C	CAT B	CAT A
IEC 61643 Test Class	I		I, II	II	III
VDE Classification	A		B	C	D
	POINT-OF-ENTRY HIGHLY EXPOSED OR CRITICALLY IMPORTANT SITES	POINT-OF-ENTRY EXPOSED OR RURAL SITES	POINT-OF-ENTRY INNER CITY SITES	SUB CIRCUITS OR NEAR TO POINT-OF-ENTRY	DISTRIBUTED CIRCUITS, POWER OUTLETS, CIRCUITS REMOTE FROM POINT-OF-ENTRY
EXPOSURE					
HIGH Ng >2	100 kA	70 kA	40 kA	20kA	10 kA
MED. Ng 0.5-2	65 kA	40 kA	20 kA	20kA	5 kA
LOW Ng <0.5	65 kA	40 kA	15 kA	5kA	3 kA

Ng = strikes/km²/year.

Recommended Products

PRODUCT SERIES	SRF N SERIES				
	DTX 120, 240; TDX 300, 400				
	SES40, SES80, SES160, SES320, SES360, SES480				
	DT1 SERIES				
	DT2/EDT2 SERIES				
	TSF Series				
	TDS1301 Series				

Selection and Application of SPDs (AS 1768)

AS 1768 PROTECTION ZONES

- Lightning protection zones (LPZ) provide a categorization of locations within a typical structure. SPDs are placed at the boundaries of these zones to reduce the likelihood of damage to downstream equipment.
- Equipment will be protected if their impulse withstand voltage (U_w) \geq the voltage protection level (U_p) of the SPD.
- The protection zones help to determine the requirements for the installation of surge protection and applicable ratings of SPDs suitable for power and signal/data lines, depending on their installation location.

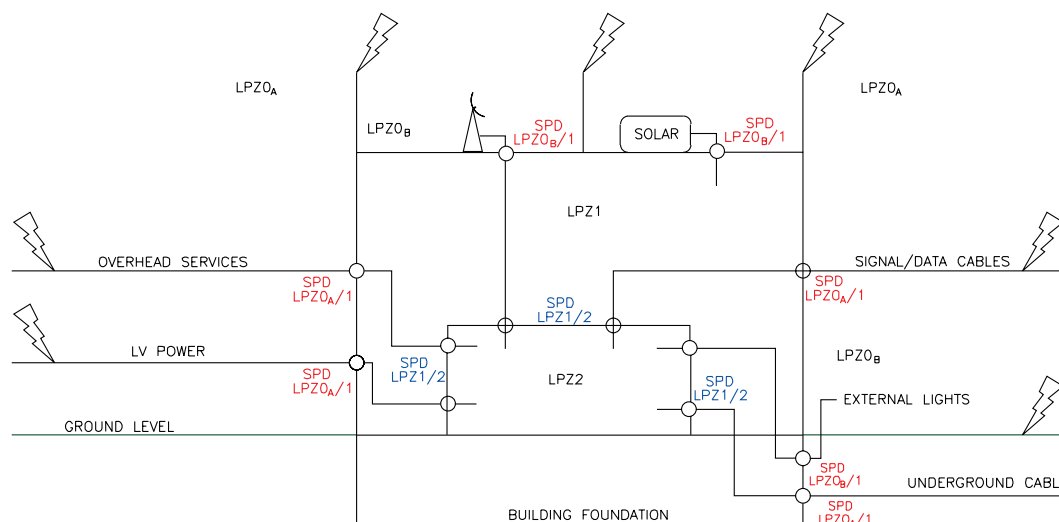

- **Primary SPDs**
(Main Switch Board or point of entry)
- **Secondary SPDs**
(Distribution Board or equipment location)

AS 1768 – SPD SELECTION, POWER CIRCUITS

Surge Ratings for A.C. Power Systems as per AS 1768 & IEC 62305

- Not all SPDs specify their I_{max} , I_n and I_{imp} ratings. An SPD conforming to any one of these ratings shall be deemed to conform.

LOW Lightning Threat Level HIGH	Zone Boundary	SPD Location	I_{max} rating, 8/20 μ s, kA	I_n rating, 8/20 μ s, kA	I_{imp} rating, 10/350 μ s, kA	nVent ERICO Products
		LPZ2/...n Secondary SPD	Long final subcircuits and supply outlets	3 to 10	2–5	–
	LPZ1/2 Secondary SPD	Major submains, short final subcircuits and load centers	40	20	–	DT2300xxR SES40
	LPZ0B/1 Primary SPD	Domestic service entrance or external services shielded from direct lightning strike	40	20	5	PVT2
	LPZ0A/1 Primary SPD	Industrial or commercial service entrance, building fed by long overhead or underground conductive services	100	40	10	DT1M275 DSD3100 DTX120 SES160
	LPZ0A/1 Primary SPD	Service entrance, building in a high lightning area (N_g greater than 2), or fitted with an LPS	100	40	10	TDX100M PVT1

In high lightning areas, it may be prudent to consider higher surge ratings for the primary SPD to provide a longer service life.

AS 1768 – SPD SELECTION, SIGNAL/DATA CIRCUITS

Surge Ratings for signal and data circuits as per AS 1768 & IEC 62305

- Not all SPDs specify their I_{TOT} and I_{imp} ratings. An SPD conforming to either of these ratings shall be deemed to conform.

LOW Lightning Threat Level HIGH	Zone Boundary	SPD Location	I_{TOT} rating, 8/20 μ s, kA	I_{imp} rating, 10/350 μ s, kA	nVent ERICO Products
		LPZ1/...n Secondary SPD	Internal marshalling cubicle or equipment cabinet	1 to 5	–
	LPZ0B/1 Secondary SPD	External signal cable shielded from direct lightning strike	5 to 10	0.5 to 1	LANRJ45 RTB
	LPZ0A/1 Primary SPD	Point of entry, long overhead or underground signal cables	10 to 20	1 to 2.5	CSP1 CCTV12
	LPZ0A/1 Primary SPD	Point of entry signal cables, building in a high lightning area (N_g greater than 2), or fitted with an LPS	10 to 20	1 to 2.5	HSP

In high lightning areas, it may be prudent to consider higher surge ratings for the primary SPD to provide a longer service life.

A Guide to Common Power Distribution Systems

Throughout the world a number of different power distribution systems are used. This guide identifies the more common of these systems. The individual product specification tables detail system suitability.

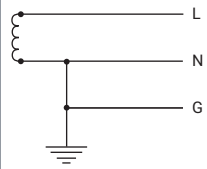
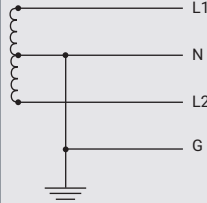
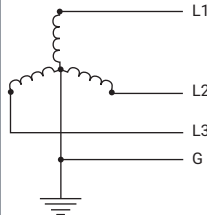
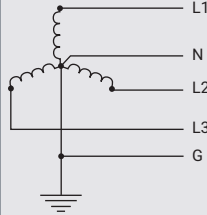
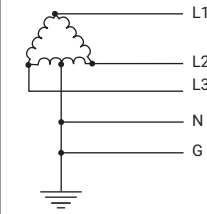
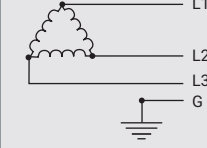
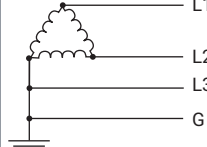
Description	Source Configuration	Typical Supply Voltages
Single Phase 1Ph, 2W+G		110 V 120 V 220 V 240 V (L-N)
Single Phase 1Ph, 3W+G Also known as Split phase or Edison system		120/240 V (L-N/L-L)
Three Phase WYE without neutral 3Ph Y, 3W+G		480 V (L-L)
Three Phase WYE with neutral 3Ph Y, 4W+G		120/208 V 220/380 V 230/400 V 240/415 V 277/480 V 347/600 V (L-N/L-L)
Delta High leg 3Ph Δ, 4W+G		120/240 V (L-N/L-L)
Delta Ungrounded 3Ph Δ, 3W+G		240 V 480 V (L-L)
Delta Grounded corner 3Ph Δ, 3W+G		240 V 480 V (L-L)

Selection and Application of AC Power System SPDs

Having determined the Class of SPD required, the correct voltage and configuration needs to be determined. The standard IEC 60364-1 details the following system configurations. In the descriptions that follow, U_0 is used for the nominal systems voltage, and U_c is used for the maximum continuous operating voltage (this is a parameter of an SPD).

TN-C System

In this system, the neutral and protective earth conductor are combined in a single conductor throughout the system. This conductor is referred to as a PEN, a "Protective Earth & Neutral". All exposed conductive equipment parts are connected to the PEN.

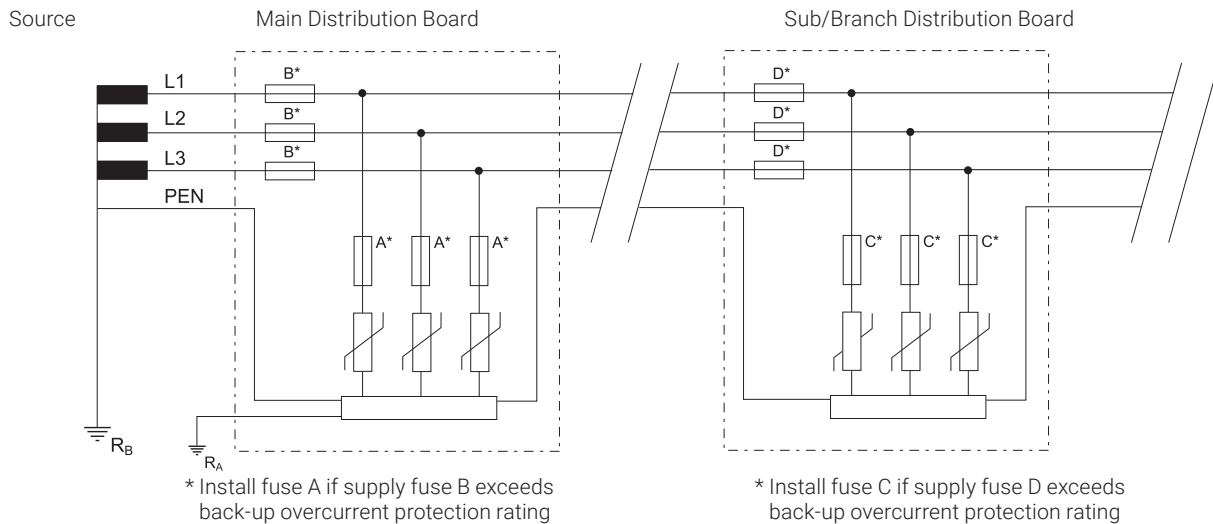

SPDs Installed	Description	Example Product
Phase to PEN ("3+0")	At least 1.1 x U_0	DT230030R

For example, on a 230 V Ph-N system, Ph-PEN protection should have a U_c rating of at least 255 V. Generally an SPD with a U_c rating of at least 275 V would be selected for 220 to 240 V systems. Often, to allow for power supply voltage fluctuations, a U_c of at least 1.3 x U_0 is recommended, such as a U_c of 300 V for a 230 V system, or nVent ERICO's TD technology would be chosen.

TN-S System

In this system, a separate neutral and protective earth conductor are run throughout. The Protective Earth (PE) conductor is normally a separate conductor, but can also be the metallic sheath of the power cable. All exposed conductive equipment parts are connected to the PE conductor.

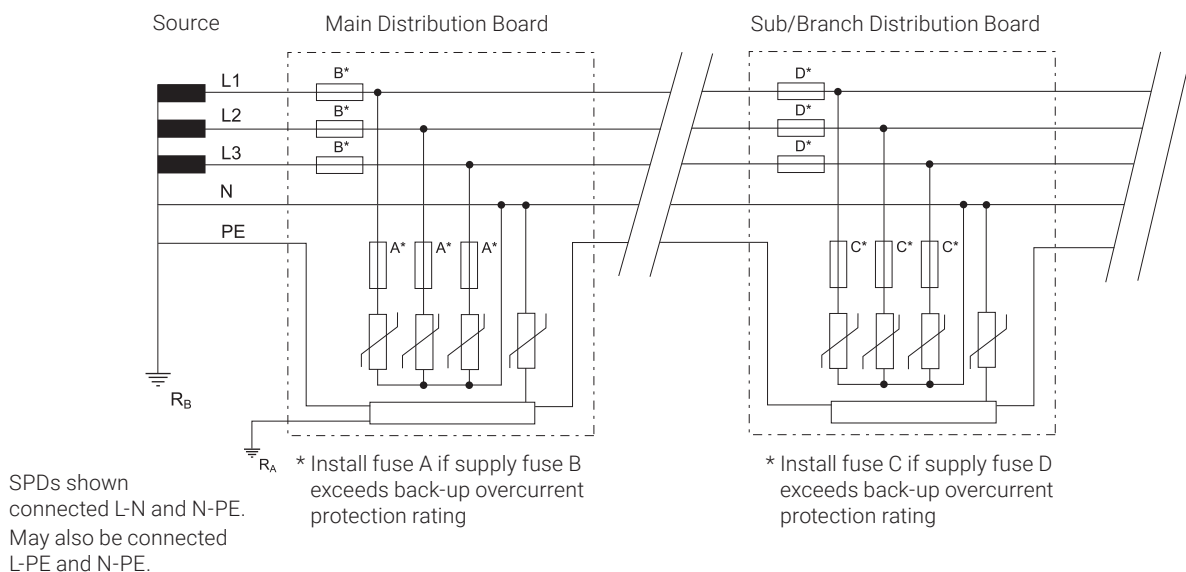

Selection and Application of AC Power System SPDs

SPDs Installed	Description	Example Product
Phase to PE ("4+0"), or Phase-N, and N-PE ("3+1")	At least 1.1 x U _{oc}	DT230040R DT230031R

For example, on a 230 V Ph-N system, Ph-PE (or Ph-N) protection should have a U_c rating of at least 255 V. Generally an SPD with a U_c rating of at least 275 V would be selected for 220 to 240 V systems. Often, to allow for power supply voltage fluctuations, a U_c of at least 1.3 x U_o is recommended, such as a U_c of 300 V for a 230 V system, or nVent ERICO's TD technology would be chosen.

TN-C-S System

In this system, the supply is configured as per TN-C, while the downstream installation is configured as per TN-S. The combined PEN conductor typically occurs between the substation and the entry point into the building, and earth and neutral are separated in the Main Distribution Board. This system is also known as Protective Multiple Earthing (PME) or Multiple Earthed Neutral (MEN). The supply PEN conductor is earthed at a number of points throughout the network and generally as close to the consumer's point-of-entry as possible.

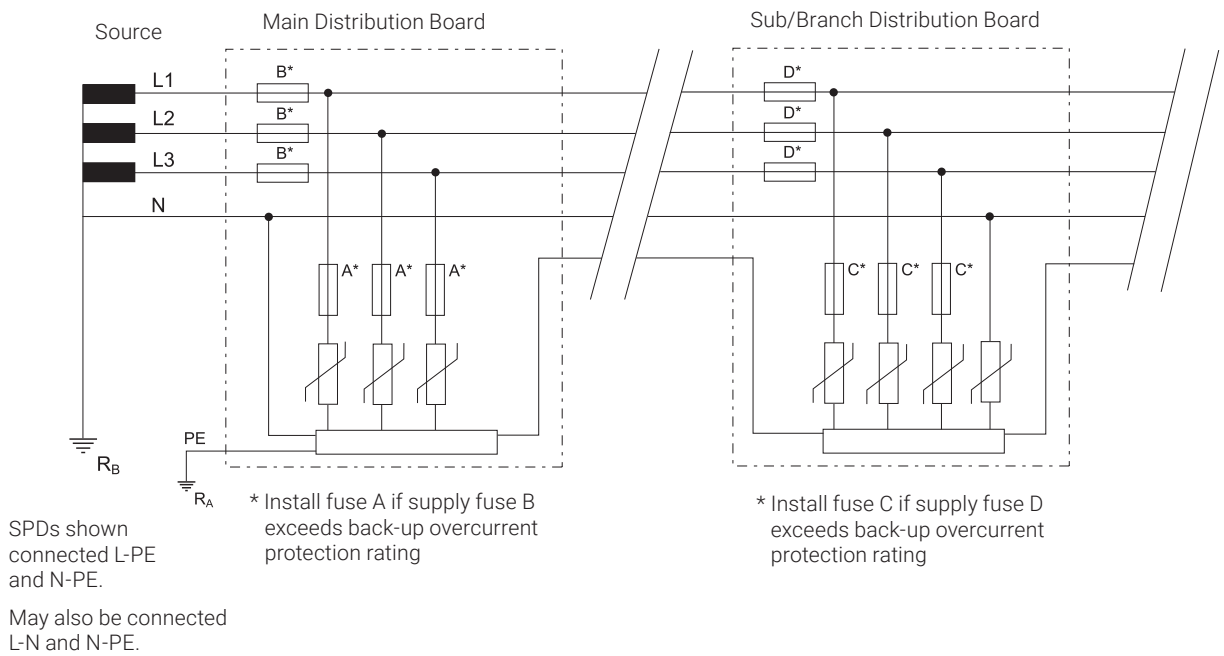

SPDs Installed	Description	Example Product
MDB: Phase to PEN ("3+0") DB: Phase to PEN ("4+0"), or Phase-N, and N-PE ("3+1")	At least 1.1 x U _o	DT130030R, DT230040R, DT230031R

For example, on a 230 V Ph-N system, Ph-PE (or Ph-N) protection should have a U_c rating of at least 255 V. Generally an SPD with a U_c rating of at least 275 V would be selected for 220 to 240 V systems. Often, to allow for power supply voltage fluctuations, a U_c of at least 1.3 x U_o is recommended, such as a U_c of 300 V for a 230 V system, or nVent ERICO's TD technology would be chosen.

Selection and Application of AC Power System SPDs

TT SYSTEM

A system having one point of the source of energy earthed and the exposed conductive parts of the installation connected to independent earthed electrodes. The incoming supply neutral is not earthed at the main distribution board.

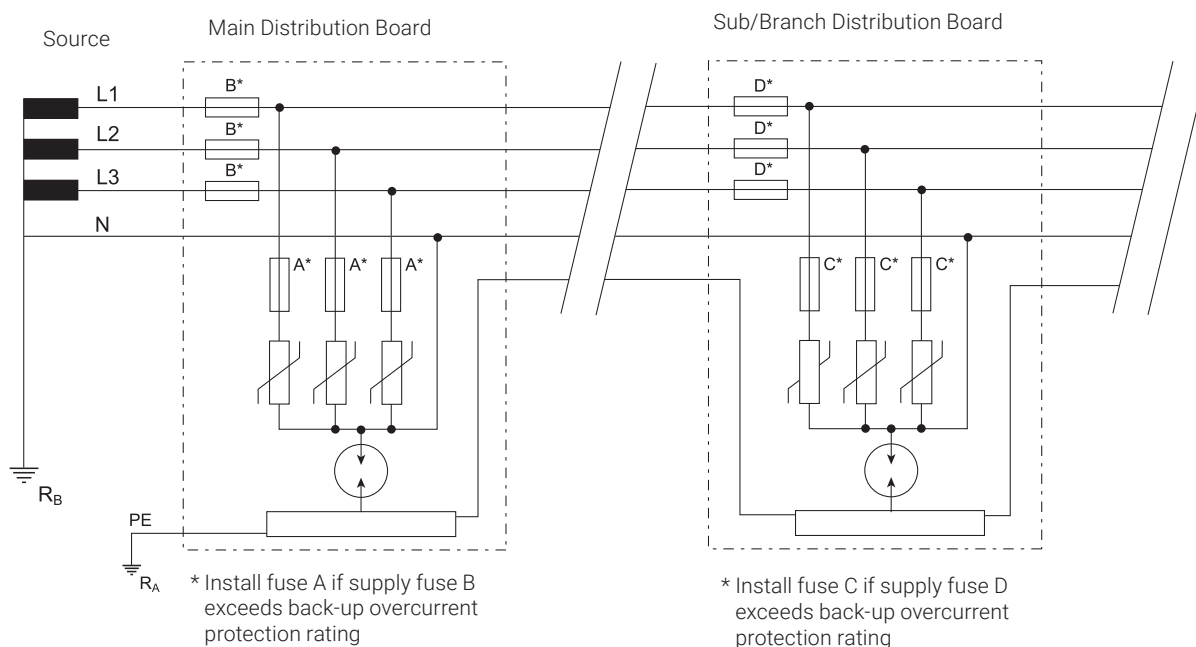

SPDs Installed	Description	Example Product
Phase to N, N-PE ("3+1")	At least 1.1 x U _{oc}	DT130031R, DT230031R

For example, on a 230 V Ph-N system, Ph-N protection should have a U_c rating of at least 255 V. Generally an SPD with a U_c rating of at least 275 V would be selected for 220 to 240 V systems. Often, to allow for power supply voltage fluctuations, a U_c of at least 1.3 x U_o is recommended, such as a U_c of 300 V for a 230 V system, or nVent ERICO's TD technology would be chosen.

In the TT system, in order for overcurrent protective devices (fuses and circuit breakers) to operate in the intended manner, it is important that SPDs must not connect directly from phase to protective ground, but from phase to neutral and neutral to ground. Therefore, the Neutral-to-PE SPD carries both the PE to neutral impulse current and the PE to phase impulse currents. This SPD is recommended to be a GDT (Gas Discharge Tube) due to their generally superior energy handling characteristics.

Selection and Application of AC Power System SPDs

IT SYSTEM

A system having no direct connection between live parts and earth, but all exposed conductive parts of the installation being connected to independent earthed electrodes. The source is either floating or earthed through a high impedance (to limit fault currents). This means that during a Phase to Earth fault, the systems continues to operate. This is detected, and maintenance efforts commenced to rectify the fault. However, during this time, the Phase to Earth voltage rises to the usual Line to Line voltage, and installed SPDs must withstand this during this time. Most installed IT systems do not utilise a neutral conductor - equipment is powered from line to line. The IT system is typically used in older installations in countries such as Norway and France. It is also used in special applications, such as intensive care wards of hospitals and special industrial applications.

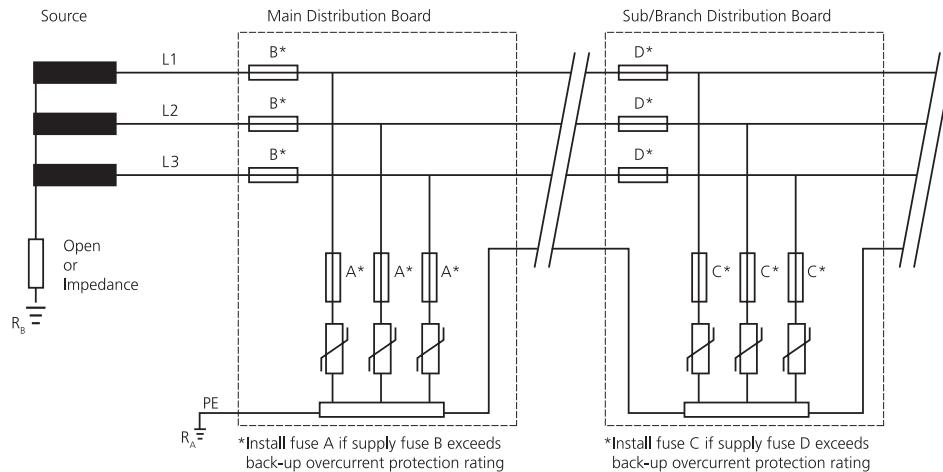

SPDs Installed	Description	Example Product
Phase to PEN ("3+0")	At least $1.73 \times U_0$	DT230030R

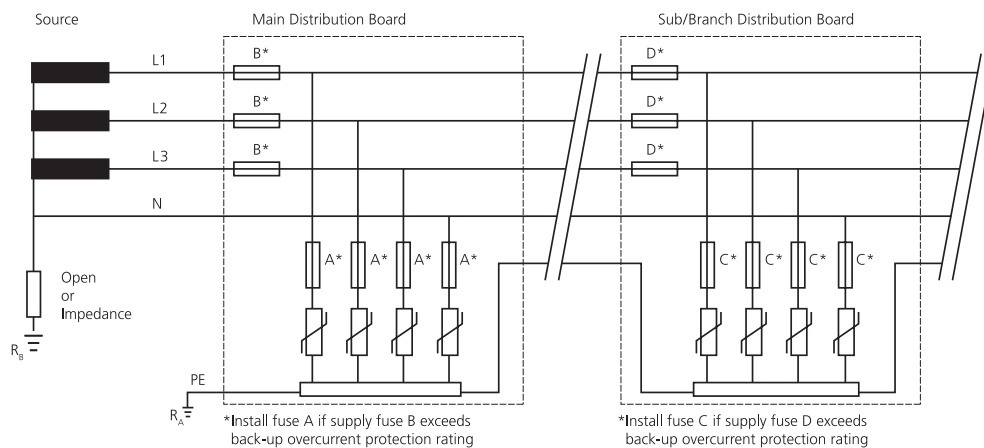

SPDs Installed	Description	Example Product
Phase to PEN ("4+0")	At least $1.73 \times U_0$	DT130040R, DT230040R

For example, on a 230 V Ph-N system, Ph-PE and N-PE protection should have a U_c rating of 440 V (allowing for the L-L voltage and a 10% tolerance). Often an additional safety margin is applied, to allow for instabilities that can occur in the ungrounded IT system, such as a U_c of 480 V.

Data and Signal Line Protection

HOW TO SELECT SURGE PROTECTION FOR DATA, SIGNALLING AND CONTROL CIRCUITS

Knowing where to install surge protection can be difficult. To ensure cost-effective protection is provided for data, signalling and control circuits, two issues need to be considered:

- Where should the SPDs be installed?
- What type of SPD is appropriate for each circuit type and location?

WHERE SHOULD THE SPD(S) BE INSTALLED?

Communications devices are at risk from transients being induced onto the interconnecting signal lines. The use of surge protection barriers, installed at either end of the lines, provides cost effective protection. Communication or signal lines that enter or exit the building pose the highest risk. In such circumstances, protection devices should be installed at the point-of-entry or at the equipment termination itself. Internal wiring which extends more than 10 to 15 m should also be protected. Twisting or shielding of cables provides a level of protection, however this should not be regarded as sufficient for the sensitive interfaces that characterize today's communication devices.

HOW TO SELECT AN SPD FOR A GIVEN LOCATION

Five parameters must be considered to ensure that surge protection devices for use on data, signalling or control circuits are effective and do not adversely affect operation of the circuit.

1. SPDs are designed to clamp the excess transient voltage to safe levels sustainable by the equipment, yet should not interfere with the normal signalling voltages. As a guide, the SPD clamping voltage should be selected to be approximately 20% higher than peak working voltage of the circuit.
2. The line current rating of the SPD should be sufficient to handle the maximum expected signalling current.
3. The SPD bandwidth should be sufficient to allow correct operation of the system without adverse attenuation. This ensures that the attenuation of the SPD at the nominal operating frequency of the system does not exceed the stated limit. For most SPDs, frequency attenuation data or a maximum recommended baud rate is generally specified.
4. The connection termination, mounting method, number of lines to be protected and other physical aspects must be considered.
5. The SPD surge rating should be appropriate for the intended location. For circuits internal to the building, surge ratings of 1–5 kA are generally sufficient. For the protection of circuits that connect to exposed lines entering or exiting the facility, 10–20 kA is recommended. Alternatively a protocol or standard may be specified that defines the above parameters. All UTB products are rated 20 kA for higher exposure areas.

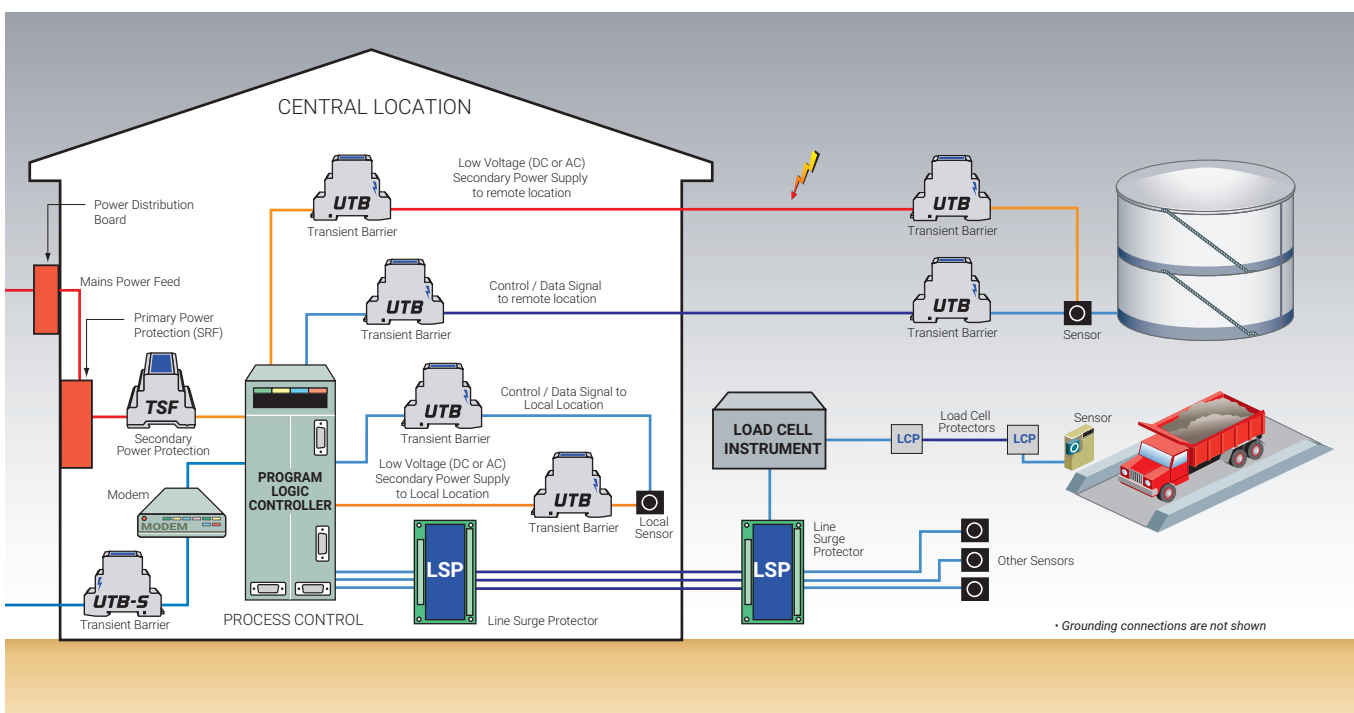

Data and Signal Line Protection

SAMPLE APPLICATIONS

2-Wire Isolated Ground Transducers/Sensors

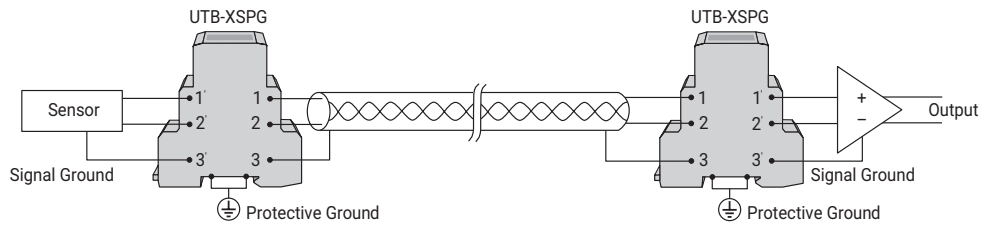

2-Wire Sensors

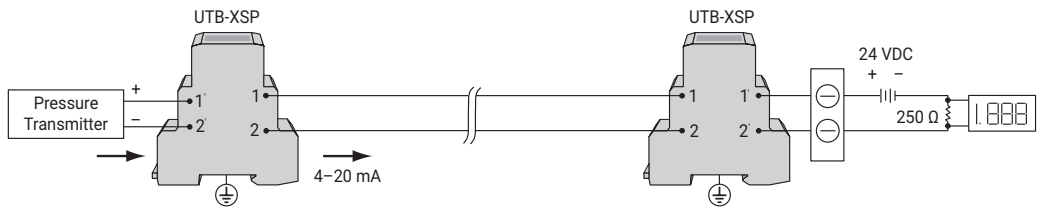

Powered Sensor Protection

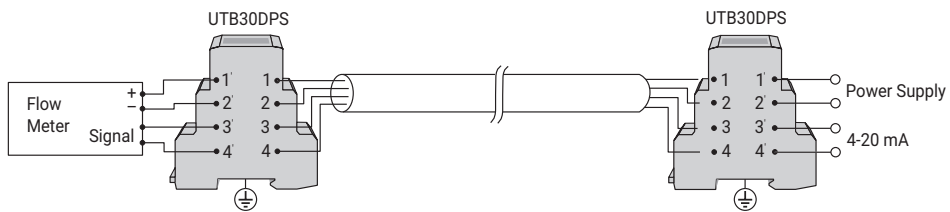

Multiple Sensor or up to 4-Wire Sensor

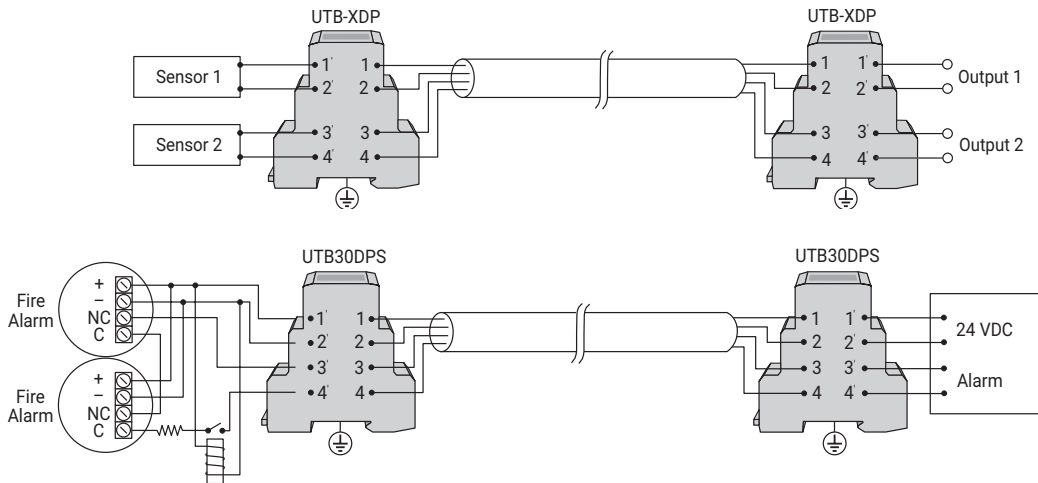

Protecting Sensors in Hazardous Locations

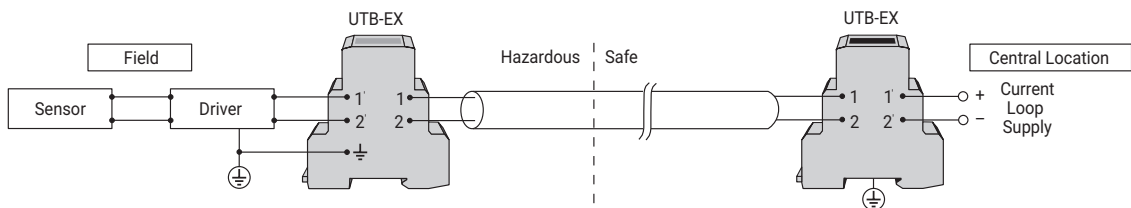

Data and Signal Line Protection

GUIDE TO DATA AND SIGNALING CIRCUITS

The selection of an SPD for communication and signalling circuits requires knowledge of the:

1. Maximum Continuous Operating Voltage (U_c)
2. Maximum line current (I_L)
3. Frequency
4. Termination (connector type and/or impedance)

Where a protocol is known, this often eliminates the need to verify product selection criteria 1–3, and occasionally 4. A number of different SPDs often meet the requirements

as defined by the protocol, so the final choice of which SPD to use is often determined by its type of physical connection, number of lines to be protected, or its surge rating. Some protocols do not define the actual connector or pin configuration, and in some cases, not all lines defined by the protocol will be used. Please refer to the documentation provided with the equipment requiring protection to ensure the proposed protection modes are adequate and that the SPD's characteristics will not interfere with normal system operation.

Protocol/Standard	Description	Applicable SPD Series
RS-232 (V.24)	Unbalanced, bi-directional communication circuit. Although standard allows +/-25 V signaling, use of more than +/-12 V is uncommon	UTB 15 SP ⁽¹⁾ , UTB 15DP ⁽²⁾ UTB 5 ⁽¹⁾
RS-422 (V.11)	Industrial version of RS-232. 0-5 V balanced signaling	UTB 5 ⁽¹⁾
RS-423	Similar to RS-232 but +/-5 V signaling used	UTB 5 ⁽¹⁾
RS-485	Similar to RS-422 but allows multiple devices to communicate. DB-9 connector is common	UTB 15
Ethernet Cat 4 Cat 5 Cat 6 10BaseT 100BaseT PoE	Ethernet is the term used to describe a family of communication protocols. *10BaseT is a 10 MHz system using twisted pair of coax cables *100BaseT is a 100 MHz system using twisted pair cables *10GBaseT is a 250 MHz system using twisted pair cables Cat 4 is a cable specification that allows operation up to 10BaseT, while Cat 5 allows operation up to 100BaseT frequencies. Power Over Ethernet	LANRJ45C6P
Telephone Lines		UTB SA ⁽²⁾ , UTB TA ⁽²⁾
4-20 mA current loop (with HART)	Common industrial communications protocol used to interface with transducers etc	UTB xDP, UTB 30DPS, UTB xSP
Binary Signals		UTB xSP ⁽¹⁾ , UTB xDP ⁽¹⁾
Bitbus (IEEE 1118)	Digital communications network based on RS-485 and SDLC allowing communication between PLCs and controllers	
CAN-Bus (data signal line)	Differential serial communications protocol defined in ISO 11898 standard	UTB 5 ⁽¹⁾
DeviceNet (data signal line)	Communication protocol used to connect industrial devices such as limit switches, motor starters to PLCs and controllers	
M-Bus	Communication protocol for networking and remote reading of heat, gas, water, and energy meters	UTB 60 ⁽¹⁾
Ex (I) - HART, 4–20 mA circuit, measurement circuits	Hazardous locations	UTB15 Ex, UTB30 Ex
Profibus - PA	Process field bus - process automation. Ideal for explosion - hazardous areas	UTB30 Ex
Strain gauge/Load cells	As used in weigh bridges etc.	LCP01A
ASDL	Asymmetric Digital Subscriber Line. Protocol for data communication over copper telephone lines. Uses single copper wire pair.	UTB TA ⁽²⁾ , UTIntegrated Service Digital Network. Protocol for voice and data over copper telephone linesB SA ⁽²⁾
HDSL	High bit rate Digital Subscriber Line. Protocol for data communication over copper telephone lines. Uses two copper wire pairs.	
ISDN	Integrated Service Digital Network. Protocol for voice and data over copper telephone lines	

1. The number of UTB's required is dependent on the number of wires being used in the signalling circuit. UTBs are designed for balanced circuits and each UTB will protect one pair of wires. The UTB can also be used to protect two unbalanced circuits.
2. The UBT TA is rated to 500 A 8/20 us and intended to meet US NEC requirements. The UTB SA are rated to 20 kA 8/20 μs and specifically designed and approved for use on the Australian telecommunication network.

Products

AC POWER SURGE PROTECTION

DT1M

The DIN rail mounted DT1M family provides reliable and effective protection against voltage transients in IEC Class I (25kA) environments. It is tested and certified to IEC standards with compact, safe and high-performance features. It could be used in a wide range of applications. The innovative and unique technological design allow DT1M series to save 50% space comparing competitor products. It could coordinate with nVent ERICO Class II or Class III SPD products.

DT2

The DIN Rail mounted DT2 family provides many of the same benefits as the DT1 Series but is specifically designed to fit within the parameters of IEC Class II environments and is certified to UL Type 1 CA. Targeting the Class II/Type 1 CA classification allows the system designer to effectively select the correct coordinated protection while keeping total project costs in check.

EDT2

The DIN Rail mounted EDT2 family of SPDs provide reliable protection against voltage transients within the IEC Class II environments and is certified to UL Type 1 CA. In addition, nVent ERICO's Transient Discriminating (TD) technology ensures continued operation during and after sustained and abnormal over-voltage events. Tested and independently certified to the IEC (via VDE) and UL standards, the EDT2 Series provides a range of safety and performance features for the harshest environments and suitable for protection within a wide range of applications. The EDT2 Series provides extended service life in the harshest of environments, ensuring your equipment and systems are kept safe and operational through extreme abnormal voltage conditions.

DTX Panel Protector

The nVent ERICO DTX120 and DTX240 Series of Surge Protective Devices (SPD) features a cUL 1449 listing and provides premium protection against damaging transients and surge currents, particularly in Type 1 and Type 2 locations. The innovative design is Field Serviceable and also includes RS-485 Connectivity for integration into Building Automation Systems. With a 120–240 kA per phase surge rating, nVent ERICO DTX120 and DTX240 are well suited for category C locations and is typically used in applications including service entrances, distribution, branch panels, MCC, lighting panels, HVAC, and more. The nVent ERICO DTX120 also features a NEMA®-4X enclosure rating, making it suitable for outdoor applications.

SES40P

The nVent ERICO SES40P Series of Surge Protective Devices (SPD) provide economical protection against damaging transients and surge events. These Type 1 devices are UL® Listed to UL 1449 Edition 5 and CSA C22.2 No. 291.1-17. This allows installations on the line or load side (Type 1 or Type 2) of the service panel in accordance with the NEC® CSA C22.2 No. 291.1-17 without the requirement for additional circuit breakers or fuses. Primary applications are service entrance, branch, commercial, industrial, and residential. Other applications include OEM panels, solar combiner boxes, UL 96A lightning protection installations and light pole applications. The housing is constructed of UV-stabilized thermoplastic and meets the UL 50 Type 4X rating, making it ideal for both indoor and outdoor applications. All of the models have a 20 kA nominal discharge current rating, the highest level recognized under the UL 1449 Edition 5 standard.



Products

AC POWER SURGE PROTECTION

SES360/480

The nVent ERICO SES360 and SES480 Series of Surge Protective Devices (SPD) provides economical protection against damaging transients and surge currents. The SES360 and SES480 Series is a cUL 1449 listed SPD for Type 1 or Type 2 locations, allowing for installation either on the line or load of service panels without requiring circuit breakers (DB models only). With a 360–480 kA per phase surge rating, the SES360 and SES480 are well suited for category C locations. Typical applications for the nVent ERICO SES360 and SES480 Series include service entrances, distribution, branch panels, MCC, lighting panels, HVAC and more. Featuring a NEMA 4 enclosure rating, the DB and DF series are also appropriate for use in outdoor applications.



SES160 / SES320

The nVent ERICO SES 160 and SES320 Series is a compact and robust design, with many features being standard. The standard features for this 160 kA or 320 kA per phase SPD include an audible alarm, pre-wired relay contacts, LED indicators and a NEMA 4X enclosure. The SES160 and SES320 F models include a UL 1283 listed filter, tested to Mil-Std 220 A; an additional Status LED; and, Ground Ref. Monitoring (GRM.) The SES320 C models include a surge counter. The SES160 and SES320 Series is well suited for service entrance, distribution, branch panels, MCC, lighting panels, HVAC, A/V systems, IT equipment and more.



SURGE FILTERS

SRF

The SRF (Surge Reduction Filters) product family combines high-energy surge diversion with surge filtering, making them ideal for primary service protection applications. Their efficient low pass filtering stage dramatically reduces the rate-of-voltage rise and the let-through voltage thereby substantially reducing the risk of physical equipment damage. They incorporate TD technology making them robust against AC power system temporary overvoltages, and their standards compliance to IEC 61643-11 Class I & Class II ensure maximum product performance with maximum product safety.



TSF

The Transient Surge Filter (TSF) product family combines nVent ERICO's Transient Discriminating (TD) technology with a low pass filter to protect against transient events and attenuate small signal RFI/EMI noise problems. Perfect for PLC controllers, SCADA systems, motor control centers, and other similar applications, the TSF also features serviceable surge modules and a compact form factor. The TSF range of products are certified to UL 1449 5th Edition, UL 1283 5th Edition (EMI Filtering), and IEC 61643-11 Class II.







DATA/SIGNAL PROTECTION

Lightning or induced surges can destroy or compromise signal communications systems and data. nVent ERICO offers multiple series of data and signal surge protection devices designed to provide transient protection for equipment from induced surges. These are also well-suited to the protection of industrial equipment and are compact in size, while offering high surge carrying capacity. nVent ERICO data and signal surge protection offers a complete solution to eliminate damage, downtime, and power disruption.



Surge Protection Product Selection



The various product solutions available are listed below. The basic division is into power protection and signal protection. Power protectors are further divided into shunt protection and series (filtering) protection. Signal protectors are generally divided by connectors types and application.

Power Protection – Non-DIN Rail					
Shunt protection for Power Circuits					
TDX YYY V ZZZ 	TDX = PRODUCT FAMILY		YYY = SURGE RATING 50 KA 100 KA 200 KA 300 KA 400 KA	V = PRODUCT VERSION M = MODULAR S = MODULAR WITH SURGE COUNTER & FILTER (100 KA & 200 KA) C = COMPACT	ZZZ = VOLTAGE CONFIGURATION 120 120/208 120/240 120/240D 240 240D 277/480 277/480TT 347/600 480D
DTX YYY V ZZZ 	DTX = PRODUCT FAMILY		YYY = SURGE RATING 120 KA 240 KA	V = PRODUCT VERSION B = BASIC F = FILTER	ZZZ = VOLTAGE CONFIGURATION 208Y 120240SP 120240HD 240D 480Y 400TT 400TTS 480D
SES40P XXX YY 	SES = PRODUCT FAMILY		XXXX = VOLTAGE CONFIGURATION 120 120/240 208 240 480 300	YY = CONFIGURATION 1P = SINGLE PHASE SP = SPLIT PHASE 3P = THREE PHASE DC = DIRECT CURRENT	
SES160/ SES320 	SES = PRODUCT FAMILY	XXXX = I_{MAX} AND TYPE 160B = 160 KA, BASIC 160F = 160 KA, FILTER 320B = 320 KA, BASIC 320F = 320 KA, FILTER 320BC = 320 kA, Counter, Basic 320FC = 320 kA, Counter, Filter	YYYY = VOLTAGE CONFIGURATION 120 120240 208 240 480 600	ZZ = CONFIGURATION V = SINGLE PHASE S OR SP = SPLIT PHASE Y = WYE D = DELTA	
SES360/ SES480 	SES = PRODUCT FAMILY	XXXX = I_{MAX} AND TYPE 360DB = 360 kA, Disconnect, Basic 360DF = 360 kA, Disconnect, Filter 480DB = 480 kA, Disconnect, Basic 480DF = 480 kA, Disconnect, Filter	YYYY = VOLTAGE CONFIGURATION 120240 480 600 240480 208	ZZ = CONFIGURATION S = SPLIT PHASE D = DELTA Y = WYE	

Surge Protection Product Selection

Power Protection – DIN Rail IEC Class 1 & Class 2 Protectors

Shunt protection for power circuits

DT1(M) YYY ZZ (R) 	DT1(M)= PRODUCT FAMILY DT1M = Dinrail IEC test Class I 25 kA DT1 = Dinrail IEC test Class I		YYY = VOLTAGE 75 = 75 V 150 = 150 V 300 = 300 V 350 = 350 V 480 = 480 V 550 = 550 V 750 = 750 V	ZZ = MODE/ VARIANT 10 = 1 + 0 20 = 2 + 0 30 = 3 + 0 40 = 4 + 0 11 = 1 + 1 31 = 3 + 1 100 = 100 kA	R = REMOTE CONTACTS
(E)DT2 YYY ZZ (R) 	(E)DT2= PRODUCT FAMILY DT2 = Dinrail IEC test Class II EDT2 = Enhanced Dinrail IEC test Class II		YYY = VOLTAGE 75 = 75 V 150 = 150 V 300 = 300 V 350 = 350 V 480 = 480 V 550 = 550 V 750 = 750 V	ZZ = MODE/ VARIANT 10 = 1 + 0 20 = 2 + 0 30 = 3 + 0 40 = 4 + 0 11 = 1 + 1 31 = 3 + 1 100 = 100 kA	R = REMOTE CONTACTS
SGTX YY (R) 	SGTX = PRODUCT FAMILY SGT1 = Spark Gap Test Class 1 SGT2 = Spark Gap Test Class 2		YY = SURGE RATING 40 = 40 kA I _n [T2] 50 = 50kA I _{imp} [T1]		R = REMOTE CONTACTS (SGT240R only)

Power Protection – Transient Surge Filters

Series protection for power circuits (6 A to 20 A)

TSF XXA YYYY 	TSF = PRODUCT FAMILY		XX = LINE CURRENT 6 = 6 A 20 = 20 A	YYY = VOLTAGE 24 = 24 V (6 A only) 120 = 120 V 240 = 240 V
--	-----------------------------	--	--	--

Power Protection – Surge Reduction Filters

Series protection for power circuits (63 A to 800 A)

SRF XXXA N 	SRF = PRODUCT FAMILY		XXX = LINE CURRENT 63 = 63 A 125 = 125 A 250 = 250 A 500 = 500 A 800 = 800 A	N = N SERIES
--	-----------------------------	--	--	---------------------

Signal Protection – Universal Transient Barriers

General purpose signal protection

UTB XXX SP 	UTB = PRODUCT FAMILY		XXX = VOLTAGE 5 = 5 V 15 = 15 V 30 = 30 V 60 = 60 V 110 = 110 V	SP = SINGLE PAIR DP = DUAL PAIR
--	-----------------------------	--	---	--

Telephone line protection

UTBSA 	UTB = PRODUCT FAMILY		SA = TELEPHONE TA = TELEPHONE, UL LISTED
---	-----------------------------	--	---

Surge Protection Product Selection

Signal Protection – Coaxial Surge Protection

General purpose coaxial cable protection

CSP1 XXX YYY



CSP1 = PRODUCT FAMILY

XXX = CONNECTOR

NB = N type, F-F bulkhead
 NMF = N type, male-female
 BNC = BNC type, male-female
 SMA = SMA type, male-female
 F = F Type male-female

YYY = MODE

90 = 90 V
 600 = 600 V

Signal Protection – High Speed & Subscriber Line Protection

High Speed twisted pair Krone block protection

HSP 10 K XXX



HSP = PRODUCT FAMILY

10 = 10 PAIR

K = KRONE BLOCK

XXX = VOLTAGE

12 = 12 V
 36 = 36 V
 72 = 72 V
 230 = 230 V

General twisted pair Krone block protection

SLP 1 RJ11



SLP = PRODUCT FAMILY

1 = 1 PAIR

RJ11A = RJ11 CONNECTOR

RJ11 = RJ11 CONNECTOR, UL LISTED

SLP 10 K1F



SLP = product family

10 = 10 pair

K = Krone block

Signal Protection – Closed Circuit & Cable TV

Coaxial Cable CCTV

CCTV 12



CCTV = PRODUCT FAMILY

12 = voltage

Signal Protection – Local Area Network

General Purpose RJ45 protection

LAN RJ45 C6P



LAN = PRODUCT FAMILY

RJ45 = connector

C6P = Category 6 Protection

SES 40P

Service Entrance Suppressor

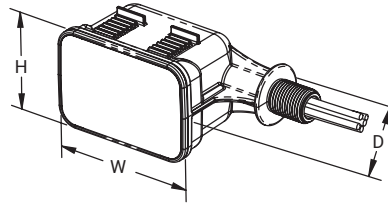

SES40P shown with optional Flush Plate (SES40PPF)

The nVent ERICO SES40P Series of Surge Protective Devices (SPD) provide economical protection against damaging transients and surge events. These Type 1 devices are UL® Listed to UL 1449 Edition 5 and CSA C22.2 No. 291.1-17. This allows installations on the line or load side (Type 1 or Type 2) of the service panel in accordance with the NEC® CSA C22.2 No. 291.1-17 without the requirement for additional circuit breakers or fuses. Primary applications are service

entrance, branch, commercial, industrial, and residential. Other applications include OEM panels, solar combiner boxes, UL 96A lightning protection installations and light pole applications. The housing is constructed of UV-stabilized thermoplastic and meets the UL 50 Type 4X rating, making it ideal for both indoor and outdoor applications. All of the models have a 20kA nominal discharge current rating, the highest level recognized under the UL 1449 Edition 5 standard.

Features

- Compact NEMA®-4X enclosure design can be flush mounted or installed in a small space
- LED status indication flag for status monitoring
- 40 kA 8/20 μ s maximum surge rating per mode protection suitable for service entrance and distribution panels
- CE, UL® 1449 Edition 5 Listed, CSA-22.2
- Optional Flush Plate and L-Bracket available
- 5-Year Warranty

Part Number	SES40P120/240SP	SES40P1201P	SES40P2083P	SES40P2401P	SES40P4801P	SES40P4803P	SES40P300DC
Nominal System Voltage (U _n)	120/240 VAC	120 VAC	120/208 VAC	240 VAC	277/480 VAC	277/480 VAC	300 VDC
Distribution System	1Ph 2W+G		3Ph 4W+G 3Ph Δ 3W+G	1Ph 2W+G		3Ph 4W+G 3Ph Δ 3W+G	DC 2W+G
Max Continuous Operating Voltage (U _c)	150/300 VAC	150 VAC	150/300 VAC	300 VAC	340/590 VAC	340/590 VAC	360 VDC
Frequency	0–100 Hz						–
Short Circuit Current Rating (SCCR)	200 kA						100 kA
Nominal Discharge Current (I _n), Per Mode	20 kA 8/20 μ s				10 kA 8/20 μ s	20 kA 8/20 μ s	
Max Discharge Current (I _{max}), Per Mode	40 kA 8/20 μ s						
Voltage Protection Rating (VPR),	L-L 1,800 V L-N 900 V	L-N 1,800 V L-PE 900 V N-PE 900 V	L-L 1,800 V L-N 800 V L-PE 1,800 V N-PE 800 V	L-N 2,500 V L-PE 1,500 V N-PE 1,200 V	L-L 4000 V L-G 2000 V	L-L 2,500 V L-N 1,500 V L-PE 2,500 V N-PE 1,500 V	DC+ - DC- 2,500 V PE - DC- 1,500 V PE - DC+ 1,500 V
Status Indication	Blue LED						
Technology	MOV with thermal disconnect						
Lead Length	91.4 cm						76.2 cm
Lead Size	4 mm ²						
Temperature	–40 to 80°C						
Enclosure Material	UL® 94 V-0 Thermoplastic, UL 50 Type 4X						
Enclosure Rating	UL 50E Type 4X, NEMA 4X, IP65						NEMA®-4X
Mounting	½" straight nipple						¾" straight nipple
Unit Weight	0.25 kg		0.39 kg	0.25 kg		0.39 kg	0.25 kg
Certification Details	UL® 1449 Edition 5 Type ½, 20 kA Mode CSA C22.2 No. 269.1-17, 2017-02						UL® 1449 Edition 5 for DC General Use, Solar PV
Complies With	ANSI®/IEEE® C62.41.2-2002 Cat A, Cat B, Cat C						
Dimensions H x D x W	6.9 cm x 7.6 cm x 12.0 cm						

SES 160/320/360/480 Series





Protect your facility with the latest from nVent ERICO Surge Protective Devices.

- ✔ Up to 480 kA per phase surge rating in a new compact design
- ✔ Optional filter with up to 64 dB attenuation
- ✔ LED indicators, audible alarms and Form C contacts
- ✔ cUL 1449 Ed. 5 and UL 1283 Ed. 7

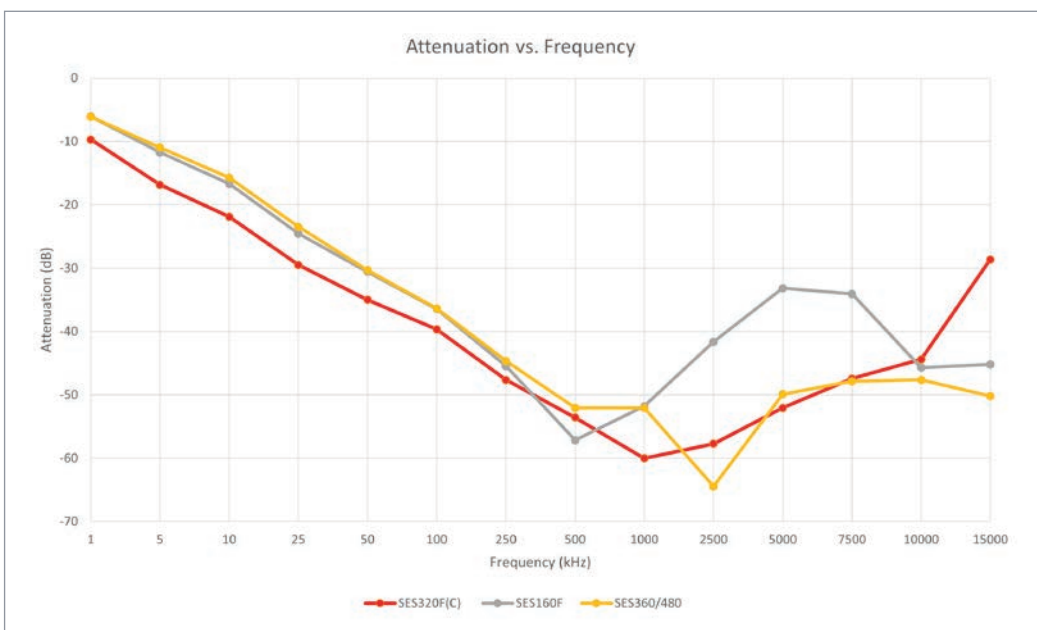

In this test (MIL-STD 220 A), the filter is effective at reducing the amplitude of AC voltage signals, especially as a frequency of 500 kHz is approached. Attenuation across a range of frequencies appears to be consistent within the voltage range tested. Frequencies greater than 15 MHz resulted in the sinusoidal signal becoming distorted beyond recognition and the Vpp unable to be measured.

nVent ERICO has a range of specialized devices that are unmatched in capabilities and performance, including surge diversion, surge filtering and TD technology.

nVent ERICO product development creates innovative products backed with 100 years of industry experience. Our products go through rigorous testing and research to validate they are ready to protect your facility.

Service Entrance Suppressor(B), 160 kA

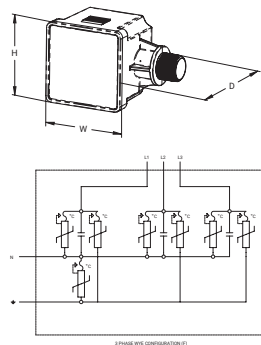

Features

- 160 kA 8/20 μ s maximum surge rating per phase
- Excellent clamping, low UL voltage protection ratings
- Relay alarming for power/phase loss and surge protection device health
- Compact design can be directly mounted to panel or installed in a small space
- Optional Flush Plate and L-Bracket available
- 10 year limited warranty

The nVent ERICO SES160B Series of Surge Protective Devices (SPD) provide economical protection against damaging transients and surge currents. cUL® 1449 Listed SPD for Type 1 or Type 2 locations. Allows for installation on the line or load of the service panels, circuit breakers not required.

With a 160 kA per phase surge rating, the SES160B is well suited for category C locations. Applications include service entrance, distribution, branch panels, MMC, lighting panels, HVAC, and more. With a NEMA® 4X enclosure rating this product series is also well suited for outdoor applications.

Part Number	SES160 B120240SP	SES160 B120V	SES160 B208Y	SES160 B240D	SES160 B240V	SES160 B480D	SES160 B480Y	SES160B 120240D	SES160B 600Y
Nominal System Voltage (U_n)	120/240 V	120 V	120/208 V	240 V	240 V	480 V	277/480 V	120/240 V	347/600 V
Distribution System	1Ph 3W+G	1Ph 2W+G	3Ph Y 4W+G	3Ph Δ 3W+G	1Ph 2W+G	3Ph Δ 3W+G	3Ph Y 4W+G	3Ph Δ 4W+G	3Ph Y 4W+G
Max Continuous Operating Voltage (U_c)	180/360 V	180 V	150/300 V	275 V	350 V	550 V	350/700 V	180/275 V	440/880 V
Frequency	0–600 Hz								
Short Circuit Current Rating (SCCR)	200 kA								
Nominal Discharge Current (I_n), Per Mode	20 kA 8/20 μ s								
Max Discharge Current (I_{max}), Per Phase	160 kA 8/20 μ s								
Voltage Protection Rating (VPR), L-L	1,200 V	–	1,000 V	1,200 V	–	1,800 V	2,000 V	1,200 V 1,500 V	2,500 V
Voltage Protection Rating (VPR), L-N	700 V	700 V	600 V	–	1,200 V	–	1,200 V	700 V 900 V	1,500 V
Voltage Protection Rating (VPR), L-PE	700 V	700 V	700 V	1,000 V	1,000 V	1,800 V	1,000 V	700 V 1,000 V	1,500 V
Voltage Protection Rating (VPR), N-PE	600 V	600 V	500 V	–	1,000 V	–	1,000 V	700 V 1,000 V	1,500 V
Protection Modes	All modes protected								
Status Indication	1 green LED per line; Audible alarm; Change-over contact (Form C dry), 240 VAC/2A								
Remote Contact Switching Capacity	2.0 A @ 240 V								
Remote Contacts	Yes								
Lead Length	45.7 cm								
Lead Size	4 mm ²								
Temperature	–40 to 85°C								
Enclosure Material	Polycarbonate								
Enclosure Rating	NEMA®-4X; UL® 50E Type 4								
Mounting	¾" straight nipple								
Unit Weight	0.53 kg								
Certification Details	CSA C22.2 No. 269.1; UL® 1449 Edition 5 Type ½, 20 kA Mode								
Complies With	ANSI®/IEEE® C62.41.2-2002 Cat A, Cat B, Cat C; ANSI®/IEEE® C62.41.1-2002 Cat A, Cat B, Cat C; ANSI®/IEEE® C62.45-2002 Cat A, Cat B, Cat C								
Dimensions H x D x W	10.7 cm x 7.4 cm x 8.3 cm								

Service Entrance Suppressor(F), 160 kA

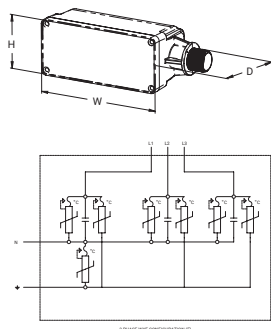

Features

- Compact design can be directly mounted to panel or installed in a small space
- Front-facing design eases installation and performance monitoring
- 160 kA 8/20 μ s maximum surge rating per phase
- Up to 57 dB attenuation (10 kHz to 100 MHz)
- Optional Flush Mounting Plate
- Ground reference monitoring triggers an alarm when N-PE mode exceeds 20 volts
- 10 year limited warranty

The nVent ERICO SES160F Series is an enhanced version of the SES160B Series. The SES160F Surge-Filter is robust, with a 160 kA per phase surge rating. The high surge rating increases both survivability and life cycle. With the addition of a filter nuisance high frequency transients on the power

distribution system are attenuated, protecting sensitive equipment. cUL® 1449 Listed SPD for Type 2 locations. Applications include service entrance, distribution, branch panels, MMC, lighting panels, HVAC, A/V systems, IT equipment, and more.

Part Number	SES160 F120240SP	SES160 F120V	SES160 F208Y	SES160 F240D	SES160 F240V	SES160 F480D	SES160 F480Y	SES160F 120240D	SES160F 600Y
Nominal System Voltage (U _n)	120/240 V	120 V	120/208 V	240 V	240 V	480 V	277/480 V	120/240 V	347/600 V
Distribution System	1Ph 3W+G	1Ph 2W+G	3Ph Y 4W+G	3Ph Δ 3W+G	1Ph 2W+G	3Ph Δ 3W+G	3Ph Y 4W+G	3Ph Δ 4W+G	3Ph Y 4W+G
Max Continuous Operating Voltage (U _c)	180/360 V	180 V	150/300 V	275 V	350 V	550 V	350/700 V	180/275 V	440/880 V
Filtering	-40 dB @ 100 kHz								
Frequency	0-600 Hz								
Short Circuit Current Rating (SCCR)	200 kA								
Nominal Discharge Current (I _n), Per Mode	20 kA 8/20 μ s								
Max Discharge Current (I _{max}), Per Phase	160 kA 8/20 μ s								
Voltage Protection Rating (VPR), L-L	1,200 V	-	1,200 V	1,200 V	-	1,800 V	2,500 V	1,500 V 1,500 V	2,500 V
Voltage Protection Rating (VPR), L-N	700 V	700 V	700 V	-	1,200 V	-	1,200 V	8,00 V 1,000 V	1,500 V
Voltage Protection Rating (VPR), L-PE	700 V	700 V	700 V	1,000 V	1,200 V	1,800 V	1,200 V	700 V 1,000 V	1,500 V
Voltage Protection Rating (VPR), N-PE	600 V	700 V	600 V	-	1,000 V	-	1,000 V	700 V 1,000 V	1,500 V
Protection Modes	All modes protected								
Status Indication	1 green LED per line; Audible alarm; Change-over contact (Form C dry), 240 VAC/2A								
Remote Contact Switching Capacity	2.0 A @ 240 V								
Remote Contacts	Yes								
Lead Length	45.7 cm								
Lead Size	4 mm ²								
Temperature	-40 to 85°C								
Enclosure Material	Polycarbonate								
Enclosure Rating	NEMA®-4X; UL® 50E Type 4								
Mounting	¾" straight nipple								
Unit Weight	0.63 kg								
Certification Details	CSA C22.2 No. 269.2; UL® 1283 Edition 7; UL® 1449 Edition 5 Type 2, 20 kA Mode"								
Complies With	ANSI®/IEEE® C62.41.2-2002 Cat A, Cat B, Cat C; ANSI®/IEEE® C62.41.1-2002 Cat A, Cat B, Cat C; ANSI®/IEEE® C62.45-2002 Cat A, Cat B, Cat C								
Dimensions H x D x W	20.2 cm x 7.8 cm x 7 cm								

Service Entrance Suppressor(B), 320 kA

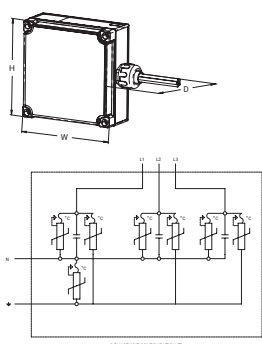

Features

- 320 kA 8/20 μ s maximum surge rating per phase
- Excellent clamping, low UL voltage protection ratings
- Relay alarming for power/phase loss and surge protection device health
- Compact design can be directly mounted to panel or installed in a small space
- Ground reference monitoring triggers an alarm when N-PE mode exceeds 20 volts
- Optional Flush Mounting Plate
- 10-year limited warranty



The nVent ERICO SES320 B Series of Surge Protective Devices (SPD) provides economical protection against damaging transients and surge currents. The B Series is a cUL 1449 listed SPD for Type 1 and Type 2 locations allowing for installation either on the line or load of service panels without requiring circuit breakers. With a 320 kA per phase surge

rating, the SES320 B is well suited for category C locations. Typical applications for the nVent ERICO SES320 B Series include service entrances, distribution, branch panels, MCC, lighting panels, HVAC, and more. Featuring a NEMA 4X enclosure rating, the B series is also appropriate for use in outdoor applications.

Part Number	SES320B 120240D	SES320B 120240SP	SES320B 120V	SES320B 208Y	SES320B 240D	SES320B 240V	SES320B 480D	SES320B 480Y	SES320B 600Y
Nominal System Voltage (U_n)	120/240 V		120 V	120/208 V	240 V		480 V	277/480 V	347/600 V
Max Continuous Operating Voltage (U_c)	180/275 V	180/360 V	180 V	150/300 V	275 V	350 V	550 V	350/700 V	440/880 V
Distribution System	3Ph Δ 4W+G	1Ph 3W+G	1Ph 2W+G	3Ph Y 4W+G	3Ph Δ 3W+G	1Ph 2W+G	3Ph Δ 3W+G	3Ph Y 4W+G	3Ph Y 4W+G
Frequency	0–600 Hz								
Short Circuit Current Rating (SCCR)	200 kA								
Voltage Protection Rating (VPR), L-G	800/900 V	800 V		700 V	900 V	1,200 V	1,800 V	1,200 V	1500 V
Voltage Protection Rating (VPR), L-L	1,200 V 1,500 V	1,200 V	–	1,000 V	1,200 V	–	1,800 V	2,000 V	2500 V
Voltage Protection Rating (VPR), L-N	800 V 1,000 V	700 V		600 V	–	1,200 V	–	1,200 V	1500 V
Voltage Protection Rating (VPR), N-G	700 V	600 V		700 V	–	1,000 V	–	1,000 V	1500 V
Nominal Discharge Current (I_n), Per Mode	20 kA 8/20 μ s								
Max Discharge Current (I_{max}), Per Phase	320 kA 8/20 μ s								
Protection Modes	All modes protected								
Status Indication	1 green LED per line; Dual color status LED, flashing red for faults; Audible alarm								
Remote Contact Switching Capacity	2.0 A @ 240 V								
Remote Contacts	Yes								
Lead Length	91.4 cm								
Lead Size	6 mm ²								
Temperature	–40 to 85°C								
Enclosure Material	Polycarbonate								
Enclosure Rating	NEMA [®] -4X; UL [®] 50E Type 4								
Mounting	¾" straight nipple								
Unit Weight	0.63 kg								
Certification Details	CSA C22.2 No. 269.1; UL [®] 1449 Edition 5 Type ½, 20 kA Mode								
Complies With	ANSI [®] /IEEE [®] C62.41.2-2002 Cat A, Cat B, Cat C; ANSI [®] /IEEE [®] C62.41.1-2002 Cat A, Cat B, Cat C ANSI [®] /IEEE [®] C62.45-2002 Cat A, Cat B, Cat C								
Dimensions H x D x W	17.5 cm x 7.6 cm x 21.29 cm								

Service Entrance Suppressor(F), 320 kA

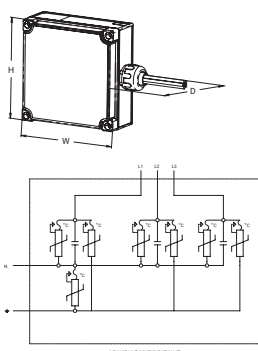

Features

- Compact design can be directly mounted to panel or installed in a small space
- Front-facing design eases installation and performance monitoring
- 320 kA 8/20 μ s maximum surge rating per phase
- Up to 60 dB attenuation (10 kHz to 100 MHz)
- Ground reference monitoring triggers an alarm when N-PE mode exceeds 20 volts
- Optional Flush Mounting Plate
- 10-year limited warranty

The nVent ERICO SES320 F Series of Surge Protective Devices (SPD) is an enhanced version of our nVent ERICO SES320B Series. The SES320 F Surge-Filter is robust and features a 320 kA per phase surge rating, increasing both survivability and overall life cycle. With the addition of a filter, bothersome high frequency transients on the power distribution system are

attenuated, therefore protecting sensitive equipment. The F Series is a cUL 1449 Listed SPD for Type 2 locations. Typical applications for the nVent ERICO SES320 F Series service entrances, distribution, branch panels, MCC, lighting panels, HVAC, A/V systems, IT equipment, and more.

Part Number	SES320F 120240D	SES320F 120240SP	SES320F 120V	SES320F 208Y	SES320F 240D	SES320F 240V	SES320F 480D	SES320F 480Y	SES320F 600Y
Nominal System Voltage (U_n)	120/240 V		120 V	120/208 V	240 V		480 V	277/480 V	347/600 V
Max Continuous Operating Voltage (U_c)	180/275 V	180/360 V	180 V	150/300 V	275 V	350 V	550 V	350/700 V	440/880 V
Distribution System	3Ph Δ 4W+G	1Ph 3W+G	1Ph 2W+G	3Ph Y 4W+G	3Ph Δ 3W+G	1Ph 2W+G	3Ph Δ 3W+G	3Ph Y 4W+G	3Ph Y 4W+G
Filtering	-40 dB @ 100 kHz								
Frequency	0-600 Hz								
Short Circuit Current Rating (SCCR)	200 kA								
Voltage Protection Rating (VPR), L-G	800 V 900 V	800 V		700 V	900 V	1,200 V	1,800 V	1,200 V	1500 V
Voltage Protection Rating (VPR), L-L	1,200 V 1,500 V	1,200 V	-	1,000 V	1,200 V	-	1,800 V	2,000 V	2500 V
Voltage Protection Rating (VPR), L-N	800 V 1,000 V	700 V		600 V	-	1,200 V	-	1,200 V	1500 V
Voltage Protection Rating (VPR), N-G	700 V	600 V		700 V	-	1,000 V	-	1,000 V	1500 V
Nominal Discharge Current (I_n), Per Mode	20 kA 8/20 μ s								
Max Discharge Current (I_{max}), Per Phase	320 kA 8/20 μ s								
Protection Modes	All modes protected								
Status Indication	1 green LED per line; Dual color status LED, flashing red for faults; Audible alarm								
Remote Contact Switching Capacity	2.0 A @ 240 V								
Remote Contacts	Yes								
Lead Length	91.4 cm								
Lead Size	6 mm ²								
Temperature	-40 to 85°C								
Enclosure Material	Polycarbonate								
Enclosure Rating	NEMA®-4X; UL® 50E Type 4								
Mounting	¾" straight nipple								
Unit Weight	0.63 kg								
Certification Details	CSA C22.2 No. 269.2; UL® 1283 Edition 7; UL® 1449 Edition 5 Type 2, 20 kA Mode								
Complies With	ANSI®/IEEE® C62.41.2-2002 Cat A, Cat B, Cat C; ANSI®/IEEE® C62.41.1-2002 Cat A, Cat B, Cat C ANSI®/IEEE® C62.45-2002 Cat A, Cat B, Cat C; Mil-Std 220A								
Dimensions H x D x W	17.5 cm x 7.6 cm x 21.29 cm								

Service Entrance Suppressor(BC), 320 kA

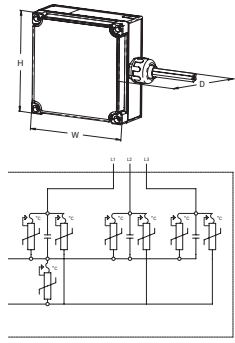

Features

- 320 kA 8/20 μ s maximum surge rating per phase
- Excellent clamping and low UL voltage protection ratings
- Features relay alarming for power/phase loss and status of SPD health
- Compact design can be directly mounted to panel or installed in a small space
- Ground reference monitoring triggers an alarm when N-PE mode exceeds 20 volts
- Optional Flush Mounting Plate
- 10-year limited warranty
- Digital Surge Counter Utilizing Non-volatile Memory

The nVent ERICO SES320 BC Series of Surge Protective Devices (SPD) provides economical protection against damaging transients and surge currents. The BC Series is a cUL 1449 listed SPD for Type 1 and Type 2 locations, allowing for installation either on the line or load of service panels without requiring circuit breakers. With a 320 kA per phase

surge rating, the SES320 BC is well suited for category C locations. Typical applications for the nVent ERICO SES320 BC Series include service entrances, distribution, branch panels, MCC, lighting panels, HVAC and more. Featuring a NEMA 4X enclosure rating, the B series is also appropriate for use in outdoor applications.

Part Number	SES320 BC208Y	SES320 BC120V	SES320 BC120240S	SES320 BC120240D	SES320 BC240D	SES320 BC240V	SES320 BC480Y	SES320 BC480D
Nominal System Voltage (U_n)	120/208 V	120 V	120/240 V	120/240 V	240 V	240 V	277/480 V	480 V
Max Continuous Operating Voltage (U_c)	150/300 V	180 V	180/360 V	180/275 V	275 V	350 V	350/700 V	550 V
Distribution System	3Ph 4W+G	1Ph 2W+G	1Ph 3W+G	3Ph Δ 4W+G	3Ph Δ 3W+G	1Ph 2W+G	3Ph Y 4W+G	3Ph Δ 3W+G
Frequency	0–600 Hz							
Short Circuit Current Rating (SCCR)	200 kA							
Voltage Protection Rating (VPR), L-G	700 V	800 V	800 V	800 V, 900 V	900 V	1,200 V	1,200 V	1,800 V
Voltage Protection Rating (VPR), L-L	1,000 V		1,200 V	1,200 V, 1,500 V	1,200 V		2,000 V	1,800 V
Voltage Protection Rating (VPR), L-N	600 V	700 V	700 V	800 V, 1,000 V		1,200 V	1,200 V	
Voltage Protection Rating (VPR), N-G	600 V	600 V	600 V	700 V		1,000 V	1,000 V	
Nominal Discharge Current (I_n), Per Mode	20 kA 8/20 μ s							
Max Discharge Current (I_{max}), Per Phase	320							
Status Indication	1 green LED per line, Dual color status LED, flashing red for faults, Audible alarm, Surge counter							
Remote Contacts	Yes							
Remote Contact Switching Capacity	2.0 A @ 240 V A							
Lead Size	6 mm ²							
Lead Length	91.4 cm							
Temperature	–40 to 85°C							
Mounting	¾" straight nipple							
Enclosure Rating	NEMA®-4X, UL® 50E Type 4							
Enclosure Material	Polycarbonate							
Unit Weight	0.63 kg	0.63 kg	0.63 kg	0.63 kg	0.63 kg	0.63 kg	0.63 kg	0.63 kg
Certification Details	CSA C22.2 No. 269.1, UL® 1449 Edition 5 Type ½, 20 kA Mode							
Complies With	ANSI®/IEEE® C62.41.1-2002 Cat A, Cat B, Cat C, ANSI®/IEEE® C62.41.1-2002 Cat A, Cat B, Cat C, ANSI®/IEEE® C62.45-2002 Cat A, Cat B, Cat C							
Dimensions H x D x W	17.5 cm x 7.6 cm x 21.29 cm							

Service Entrance Suppressor(FC), 320 kA

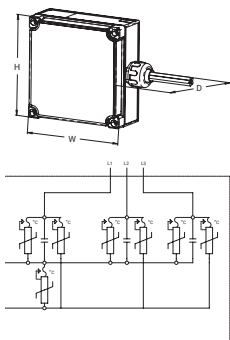

Features

- Compact design can be directly mounted to panel or installed in a small space
- Front-facing design simplifies installation and performance monitoring
- 320 kA 8/20 μ s maximum surge rating per phase
- Up to 60 dB attenuation (10 kHz to 100 MHz)
- Ground reference monitoring triggers an alarm when N-PE mode exceeds 20 volts
- Optional Flush Mounting Plate
- 10-year limited warranty
- Digital Surge Counter Utilizing Non-volatile Memory

The nVent ERICO SES320 FC Series of Surge Protective Devices (SPD) is an enhanced version of our nVent ERICO SES320BC Series. The robust SES320 FC Surge-Filter features a 320 kA per phase surge rating, increasing both survivability and overall life cycle. With the addition of a filter, bothersome high frequency transients on the power

distribution system are attenuated, ultimately protecting sensitive equipment. The FC Series is a cUL 1449 Listed SPD for Type 2 locations.

Typical applications for the nVent ERICO SES320 FC Series service entrances, distribution, branch panels, MCC, lighting panels, HVAC, A/V systems, IT equipment and more.

Part Number	SES320 FC208Y	SES320 FC120V	SES320 FC120240S	SES320 FC120240D	SES320 FC240D	SES320 FC240V	SES320 FC480Y	SES320 FC480D
Nominal System Voltage (U_n)	120/208 V	120 V	120/240 V	120/240 V	240 V	240 V	277/480 V	480 V
Max Continuous Operating Voltage (U_c)	150/300 V	180 V	180/360 V	180/275 V	275 V	350 V	350/700 V	550 V
Distribution System	3Ph Y 4W+G	1Ph 2W+G	1Ph 3W+G	3Ph Δ 4W+G	3Ph Δ 3W+G	1Ph 2W+G	3Ph Y 4W+G	3Ph Δ 3W+G
Frequency	0–600 Hz							
Filtering	-40 dB @ 100 kHz dB	-40 dB @ 100 kHz dB	-40 dB @ 100 kHz dB	-40 dB @ 100 kHz dB	-40 dB @ 100 kHz dB	-40 dB @ 100 kHz dB	-40 dB @ 100 kHz dB	-40 dB @ 100 kHz dB
Short Circuit Current Rating (SCCR)	200 kA							
Voltage Protection Rating (VPR), L-G	700 V	800 V	800 V	800 V, 900 V	900 V	1,200 V	1,200 V	1,800 V
Voltage Protection Rating (VPR), L-L	1,000 V		1,200 V	1,200 V, 1,500 V	1200 V		2,000 V	1,800 V
Voltage Protection Rating (VPR), L-N	600 V	700 V	700 V	800 V, 1,000 V		1,200 V	1,200 V	
Voltage Protection Rating (VPR), N-G	600 V	600 V	600 V	700 V		1,000 V	1,000 V	
Nominal Discharge Current (I_n), Per Mode	20 kA 8/20 μ s							
Max Discharge Current (I_{max}), Per Phase	320							
Status Indication	1 green LED per line, Dual color status LED, flashing red for faults, Audible alarm, Surge counter							
Remote Contacts	Yes							
Remote Contact Switching Capacity	2.0 A @ 240 V A							
Lead Size	6 mm ²							
Lead Length	91.4 cm							
Temperature	-40 to 85°C							
Mounting	3/4" straight nipple							
Enclosure Rating	NEMA [®] -4X, UL [®] 50E Type 4							
Enclosure Material	Polycarbonate							
Certification Details	CSA C22.2 No. 269.1, UL [®] 1449 Edition 5 Type 2, 20 kA Mode UL [®] 1283 Edition 7							
Complies With	ANSI [®] /IEEE [®] C62.41.1-2002 Cat A, Cat B, Cat C, ANSI [®] /IEEE [®] C62.41.1-2002 Cat A, Cat B, Cat C, ANSI [®] /IEEE [®] C62.45-2002 Cat A, Cat B, Cat C							
Dimensions H x D x W	17.5 cm x 7.6 cm x 21.29 cm							
Unit Weight	0.63 kg							

Service Entrance Suppressor(DB), 360 kA

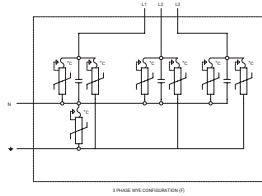

Features

- Front-facing design simplifies installation and performance monitoring
- 360 kA 8/20 μ s maximum surge rating per phase
- Advanced monitoring includes Surge and TOV Counters with time and date stamping
- Rotatable, full color graphics-based LCD utilizing a PIC Micro Controller
- Repetitive impulse tested to 10,000 strikes per mode
- Rotary Disconnect included, standard for safe servicing
- 10-year limited warranty

The nVent ERICO SES360 DB Series of Surge Protective Devices (SPD) provides economical protection against damaging transients and surge currents. The DB Series is a cUL 1449 listed SPD for Type 1 and Type 2 locations, allowing for installation either on the line or load of service panels without requiring circuit breakers. With a 360 kA per phase

surge rating, the SES360 DB is well suited for category C locations. Typical applications for the nVent ERICO SES360 DB Series include service entrances, distribution, branch panels, MCC, lighting panels, HVAC and more. Featuring a NEMA 4 enclosure rating, the DB series is also appropriate for use in outdoor applications.

Part Number	SES360 DB208Y	SES360 DB120240S	SES360 DB120240D	SES360 DB240480S	SES360 DB240480D	SES360 DB480Y	SES360 DB600Y	SES360 DB480D
Nominal System Voltage (U_n)	120/208 V	120/240 V	120/240 V	240/480 V	240/480 V	277/480 V	347/600 V	480 V
Max Continuous Operating Voltage (U_c)	150/300 V	175/350 V	175/275 V	320/550 V	350/550 V	320/700 V	420/880 V	550 V
Distribution System	3Ph Y 4W+G	1Ph 3W+G	3Ph Δ 4W+G	1Ph 3W+G	3Ph Δ 4W+G	3Ph Y 4W+G	3Ph Y 4W+G	3Ph Δ 3W+G
Frequency	0–600 Hz							
Short Circuit Current Rating (SCCR)	200 kA							
Voltage Protection Rating (VPR), L-G	800 V	800 V	1,000 V, 1,000 V	1,200 V	1,800 V, 1,800 V	1,200 V	1,500 V	1,800 V
Voltage Protection Rating (VPR), L-L	1,000 V	1,800 V	1,200 V, 1,500 V	2,500 V	2,000 V, 2,500 V	2,000 V	2,500 V	1,800 V
Voltage Protection Rating (VPR), L-N	800 V	800 V	800 V, 1,000 V	1,200 V	1,200 V, 1,800 V	1,200 V	1,500 V	–
Voltage Protection Rating (VPR), N-G	800 V	800 V	800 V	1,200 V	1,200 V	1,200 V	1,500 V	–
Nominal Discharge Current (I_n), Per Mode	20 kA 8/20 μ s							
Max Discharge Current (I_{max}), Per Phase	360 kA 8/20 μ s							
Status Indication	2 Tri Color LEDs per phase, Audible alarm with silence switch, Graphics-based LCD with Resettable Surge and TOV Counter with Time/Date Stamp							
Remote Contacts	Yes							
Remote Contact Switching Capacity	5.0 A @ 240 V A							
Lead Size	6 mm ² –25 mm ²							
Temperature	–35 to 75°C							
Mounting	Flange Mount							
Enclosure Rating	NEMA [®] -4, UL [®] 50E Type 4							
Enclosure Material	Metal							
Complies With	ANSI [®] /IEEE [®] C62.41.1-2002 Cat A, Cat B, Cat C, ANSI [®] /IEEE [®] C62.41.1-2002 Cat A, Cat B, Cat C, ANSI [®] /IEEE [®] C62.45-2002 Cat A, Cat B, Cat C, UL [®] 96A and NEC [®] Article 285							
Unit Weight	8.26 kg							
Certification Details	CSA C22.2 No. 269.1, UL [®] 1449 Edition 5 Type ½, 20 kA Mode							
Impulse Life	10,000 Impulses at 10 kA 8/20 μ s							
Dimensions H x D x W	42.6 cm x 33.5 cm x 18.4 cm							

Service Entrance Suppressor(DF), 360 kA

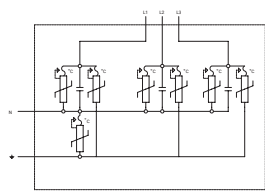

Features

- Front-facing design simplifies installation and performance monitoring
- 360 kA 8/20 μ s maximum surge rating per phase
- Up to 64 dB attenuation (10 kHz to 100 MHz)
- Advanced monitoring includes Surge and TOV Counters with time and date stamping
- Rotatable, full color graphics-based LCD utilizing a PIC Micro Controller
- Repetitive impulse tested to 10,000 strikes per mode
- Rotary Disconnect included, standard for safe servicing
- 10-year limited warranty

The nVent ERICO SES360 DF Series of Surge Protective Devices (SPD) is an enhanced version of our nVent ERICO SES360 DB Series. The robust SES360 DF Surge-Filter features a 360 kA per phase surge rating, increasing both survivability and overall life cycle. With the addition of a filter, bothersome high frequency transients on the power distribution system

are attenuated, ultimately protecting sensitive equipment. The DF Series is a cUL 1449 Listed SPD for Type 2 locations. Typical applications for the nVent ERICO SES360 DF Series service entrances, distribution, branch panels, MCC, lighting panels, HVAC, A/V systems, IT equipment and more.

Part Number	SES360 DF208Y	SES360 DF120240S	SES360 DF120240D	SES360 DF240480S	SES360 DF240480D	SES360 DF480Y	SES360 DF600Y	SES360 DF480D
Nominal System Voltage (U_n)	120/208 V	120/240 V	120/240 V	240/480 V	240/480 V	277/480 V	347/600 V	480 V
Max Continuous Operating Voltage (U_c)	150/300 V	175/350 V	175/275 V	320/550 V	350/550 V	320/700 V	420/880 V	550 V
Distribution System	3Ph Y 4W+G	3Ph Δ 3W+G	3Ph Δ 4W+G	1Ph 3W+G	3Ph Δ 4W+G	3Ph Y 4W+G	3Ph Y 4W+G	3Ph Δ 3W+G
Frequency	0–600 Hz							
Filtering	–64 dB from 10 kHz to 100 MHz							
Short Circuit Current Rating (SCCR)	200 kA							
Voltage Protection Rating (VPR), L-G	800 V	800 V	1,000 V, 1,000 V	1,200 V	1,800 V, 1,800 V	1,200 V	1,500 V	1,800 V
Voltage Protection Rating (VPR), L-L	1,000 V	1,800 V	1,200 V, 1,500 V	2,000 V	2,000 V, 2,500 V	2,000 V	2,500 V	1,800 V
Voltage Protection Rating (VPR), L-N	800 V	800 V	800 V, 1,000 V	1,200 V	1,200 V, 1,800 V	1,200 V	1,500 V	–
Voltage Protection Rating (VPR), N-G	800 V	800 V	800 V, 800 V	1,200 V	1,200 V	1,200 V	1,500 V	–
Nominal Discharge Current (I_n), Per Mode	20 kA 8/20 μ s							
Max Discharge Current (I_{max}), Per Phase	360 kA 8/20 μ s							
Status Indication	2 Tri Color LEDs per phase, Audible alarm with silence switch, Graphics-based LCD with Resettable Surge and TOV Counter with Time / Date Stamp							
Remote Contacts	Yes							
Remote Contact Switching Capacity	5.0 A @ 240 V							
Lead Size	6 mm ² –25 mm ²							
Temperature	–35 to 75°C							
Mounting	Flange Mount							
Enclosure Rating	NEMA [®] -4; UL 50E Type 4							
Enclosure Material	Metal							
Unit Weight	8.26 kg							
Complies With	ANSI [®] /IEEE [®] C62.41.2-2002 Cat A, Cat B, Cat C, ANSI [®] /IEEE [®] C62.41.1-2002 Cat A, Cat B, Cat C, ANSI [®] /IEEE [®] C62.45-2002 Cat A, Cat B, Cat C, UL [®] 96A and NEC [®] Article 285							
Certification Details	CSA C22.2 No. 269.1, UL [®] 1449 Edition 5 Type 2, 20 kA Mode, UL [®] 1283 Edition 7							
Impulse Life	10,000 Impulses at 10 kA 8/20 μ s							
Dimensions H x D x W	42.6 cm x 33.5 cm x 18.4 cm							

Service Entrance Suppressor(DB), 480 kA

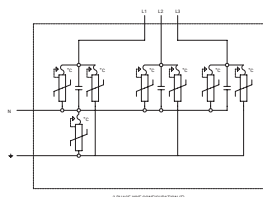

The nVent ERICO SES480 DB Series of Surge Protective Devices (SPD) provides economical protection against damaging transients and surge currents. The DB Series is a cUL 1449 listed SPD for Type 1 and Type 2 locations allowing for installation either on the line or load of service panels without requiring circuit breakers. With a 480 kA per phase

Features

- Front-facing design simplifies installation and performance monitoring
- 480 kA 8/20 μ s maximum surge rating per phase
- Advanced monitoring includes Surge and TOV Counters with time and date stamping
- Rotatable, full color graphics-based LCD utilizing a PIC Micro Controller
- Repetitive impulse tested to 10,000 strikes per mode
- Rotary Disconnect included, standard for safe servicing
- 10-year limited warranty

surge rating, the SES480 DB is well suited for category C locations. Typical applications for the nVent ERICO SES480 DB Series include service entrances, distribution, branch panels, MCC, lighting panels, HVAC and more. Featuring a NEMA 4 enclosure rating, the DB series is also appropriate for use in outdoor applications.

Part Number	SES480 DB208Y	SES480 DB240480S	SES480 DB480Y	SES480 DB240480D	SES480 DB600Y	SES480 DB480D	SES480 DB600D
Nominal System Voltage (U_n)	120/208 V	240/480 V	277/480 V	240/480 V	347/600 V	480 V	600 V
Max Continuous Operating Voltage (U_c)	150/300 V	320/550 V	320/700 V	320/550 V	420/880 V	550 V	680 V
Distribution System	3Ph Y 4W+G	1Ph 3W+G	3Ph Y 4W+G	3Ph Δ 4W+G	3Ph Y 4W+G	3Ph Δ 3W+G	3Ph Δ 3W+G
Frequency	0–600 Hz						
Short Circuit Current Rating (SCCR)	200 kA						
Voltage Protection Rating (VPR), L-G	800 V	1,200 V	1,200 V	1,800 V, 1,800 V	1,500 V	1,800 V	2,000 V
Voltage Protection Rating (VPR), L-L	1,000 V	2,500 V	2,000 V	2,000 V, 2,500 V	2,500 V	1,800 V	1,800 V
Voltage Protection Rating (VPR), L-N	800 V	1,200 V	1,200 V	1,200 V, 1,800 V	1,500 V	–	–
Voltage Protection Rating (VPR), N-G	800 V	1,200 V	1,200 V	1,200 V	1,500 V	–	–
Nominal Discharge Current (I_n), Per Mode	20 kA 8/20 μ s						
Max Discharge Current (I_{max}), Per Phase	480 kA 8/20 μ s						
Status Indication	2 Tri Color LEDs per phase, Audible alarm with silence switch, Graphics-based LCD with Resettable Surge and TOV Counter with Time / Date Stamp						
Remote Contacts	Yes						
Remote Contact Switching Capacity	5.0 A @ 240 V						
Lead Size	6 mm ² – 25 mm ²						
Temperature	–35 to 75°C						
Mounting	Flange Mount						
Enclosure Rating	NEMA [®] -4, UL [®] 50E Type 4						
Enclosure Material	Metal						
Complies With	ANSI [®] /IEEE [®] C62.41.2-2002 Cat A, Cat B, Cat C, ANSI [®] /IEEE [®] C62.41.1-2002 Cat A, Cat B, Cat C, ANSI [®] /IEEE [®] C62.45-2002 Cat A, Cat B, Cat C						
Unit Weight	8.26 kg						
Certification Details	CSA C22.2 No. 269.1, UL [®] 1449 Edition 5 Type ½, 20 kA Mode						
Impulse Life	10,000 Impulses at 10 kA 8/20 μ s						
Dimensions H x D x W	42.6 cm x 33.5 cm x 18.4 cm						

Service Entrance Suppressor(DF), 480 kA

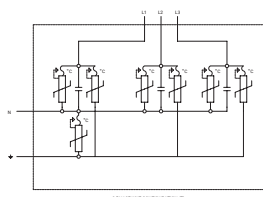

Features

- Front-facing design eases installation and performance monitoring
- 480 kA 8/20 μ s maximum surge rating per phase
- Up to 64 dB attenuation (10 kHz to 100 MHz)
- Advanced monitoring includes Surge and TOV Counters with time and date stamping
- Rotatable, full color graphics-based LCD utilizing a PIC Micro Controller
- Repetitive impulse tested to 10,000 strikes per mode
- Rotary Disconnect included, standard for safe servicing
- 10-year limited warranty

The nVent ERICO SES480 DF Series of Surge Protective Devices (SPD) is an enhanced version of our nVent ERICO SES480 DB Series. The robust SES480 DF Surge-Filter features a 480 kA per phase surge rating, increasing both survivability and overall life cycle. With the addition of a filter, bothersome high frequency transients on the power distribution system are

attenuated, ultimately protecting sensitive equipment. The DF Series is a cUL 1449 Listed SPD for Type 2 locations. Typical applications for the nVent ERICO SES480 DF Series service entrances, distribution, branch panels, MCC, lighting panels, HVAC, A/V systems, IT equipment and more.

Part Number	SES480 DF600D	SES480 DF240480S	SES480 DF240480D	SES480 DF208Y	SES480 DF480Y	SES480 DF600Y	SES480 DF480D
Nominal System Voltage (U_n)	600 V	240/480 V	240/480 V	120/208 V	277/480 V	347/600 V	480 V
Distribution System	3Ph Δ 3W+G	1Ph 3W+G	3Ph Δ 4W+G	3Ph Y 4W+G	3Ph Y 4W+G	3Ph Y 4W+G	3Ph Δ 3W+G
Frequency	0–600 Hz						
Filtering	–64 dB from 10 kHz to 100 MHz						
Short Circuit Current Rating (SCCR)	200 kA						
Voltage Protection Rating (VPR), L-G	2,000 V	1,200 V	1,800 V, 1,800 V	800 V	1,200 V	1,500 V	1,800 V
Voltage Protection Rating (VPR), L-L	2,000 V	2,000 V	2,000 V, 2,500 V	1,000 V	2,000 V	2,500 V	1,800 V
Voltage Protection Rating (VPR), L-N	–	1,200 V	1,200 V, 1,800 V	800 V	1,200 V	1,500 V	–
Voltage Protection Rating (VPR), N-G	–	1,200 V	1,800 V, 1,800 V	800 V	1,200 V	1,500 V	–
Nominal Discharge Current (I_n), Per Mode	20 kA 8/20 μ s						
Max Discharge Current (I_{max}), Per Phase	480 kA 8/20 μ s						
Status Indication	2 Tri Color LEDs per phase, Audible alarm with silence switch, Graphics-based LCD with Resettable Surge and TOV Counter with Time/Date Stamp						
Remote Contacts	Yes						
Remote Contact Switching Capacity	5.0 A @ 240 V						
Lead Size	6 mm ² – 25 mm ²						
Temperature	–35 to 75°C						
Mounting	Flange Mount						
Enclosure Rating	NEMA [®] -4, UL [®] 50E Type 4						
Enclosure Material	Metal						
Certification Details	CSA C22.2 No. 269.1, UL [®] 1449 Edition 5 Type 2, 20 kA Mode, UL [®] 1283 Edition 7						
Complies With	ANSI [®] /IEEE [®] C62.41.2-2002 Cat A, Cat B, Cat C, ANSI [®] /IEEE [®] C62.41.1-2002 Cat A, Cat B, Cat C, ANSI [®] /IEEE [®] C62.45-2002 Cat A, Cat B, Cat C						
Unit Weight	8.26 kg						
Impulse Life	10,000 Impulses at 10 kA 8/20 μ s						
Dimensions H x D x W	42.6 cm x 33.5 cm x 18.4 cm						

SES Accessories



SES40P Accessories



SES40PBRK
Mounting L-Bracket for SES40P Series



SES40PFP
SES40P flush plate kit for mounting behind drywall

SES160 Accessories



SES160BFP
SES160B flush plate kit for mounting behind drywall



SES160FFP
SES160F flush plate kit for mounting behind drywall



SES160LBRACKET
Mounting L-Bracket for SES160 B & F Series

SES320 Accessories



SES320FP
SES320 Series flush plate kit for mounting behind drywall

DT Panel Protector (B), 120 kA

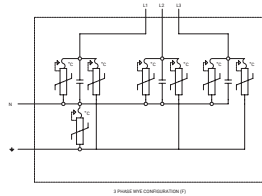

Features

- Excellent clamping and low UL voltage protection ratings
- Features relay alarming for power/phase loss and status of SPD health
- Design allows for easy removal and replacement of surge modules via lever assist
- RS-485 Interface Standard
- 10 Year Warranty



The nVent ERICO DTX120 Series of Surge Protective Devices (SPD) features a cUL 1449 listing and provides premium protection against damaging transients and surge currents, particularly in Type 1 and Type 2 locations. The innovative design allows for installation either on the line or load of the service panels and removes the need for circuit breakers (B Version Only). With a 120 kA per phase surge rating,

nVent ERICO DTX120 is well suited for category C locations and is typically used in applications including service entrances, distribution, branch panels, MCC, lighting panels, HVAC, and more. The nVent ERICO DTX120 also features a NEMA®-4X enclosure rating, making it suitable for outdoor applications.

Part Number	DTX120 B120240SP	DTX120 B120240HD	DTX120 B208Y	DTX120 B240D	DTX120 B480D	DTX120 B480Y
Nominal System Voltage (U _n)	120/240 V	120/240 V	120/208 V	240 VAC	480 V	277/480 V
Max Continuous Operating Voltage (U _c)	150/300 VAC	150/275 VAC	150/300 VAC	275 VAC	510 VAC	350/700 VAC
Distribution System	1Ph 3W+G	3PhΔ 4W+G	3Ph 4W+G	3PhΔ 3W+G	3PhΔ 3W+G	3Ph 4W+G
Protection Modes	L-N, L-PE, N-PE	L-N, L-PE, N-PE	L-N, L-PE, N-PE	L-PE	L-PE	L-N, L-PE, N-PE
Frequency	50–60 Hz					
Short Circuit Current Rating (SCCR)	200 kA					
Nominal Discharge Current (I _n), UL	20 kA 8/20 μs					
Max Discharge Current (I _{max}), Per Phase	120 kA 8/20 μs					
Impulse Current (I _{imp}), Per Mode	12.5 kA 10/350 μs					
Voltage Protection Rating (VPR), L-G	700 V	1,200 V	700 V	1,000 V	1,800 V	1,200 V
Voltage Protection Rating (VPR), L-L	1,000 V	1,500 V	1,200 V	1,000 V	1,800 V	2,000 V
Voltage Protection Rating (VPR), L-N	700 V	800 V	700 V	–	–	1,200 V
Voltage Protection Rating (VPR), N-G	700 V	1,500 V	600 V	–	–	1,200 V
Status Indication	Audible alarm with silence switch. Dual color status LED, Mechanical flag, OLED Display, Resettable Surge/TOV Counter					
Technology	Hybrid technology utilizing thermal disconnects					
Remote Contacts	Yes (Form C)					
Temperature	–40 to 80°C					
Mounting	4 Screw Locations					
Enclosure Rating	NEMA 4X; UL 50E Type 4					
Enclosure Material	Metal with PC Lid					
Certification Details	CSA C22.2 No. 269.2; UL® 1449 Edition 5 Type ½, 20 kA Mode					
Complies With	ANSI®/IEEE® C62.41.2-2002 Cat A, Cat B, Cat C; ANSI®/IEEE® C62.41.1-2002 Cat A, Cat B, Cat C; ANSI®/IEEE® C62.45-2002 Cat A, Cat B, Cat C					
Unit Weight	2.70 kg	2.90 kg	2.86 kg	2.80 kg	2.88 kg	3.07 kg
Dimensions H x D x W	33.1 cm x 9.8 cm x 10.2 cm					
Lead Size	2.5 mm ² –16 mm ²					
Replacement Module	DT2180DTXM	DT2180DTXM DT2275DTXM	DT2150DTXM	DT2275DTXM	DT2510DTXM	DT2350M

DT Panel Protector (F), 120 kA

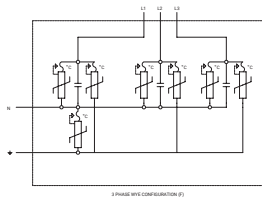

The nVent ERICO DTX120 Series of Surge Protective Devices (SPD) features a cUL 1449 listing and provides premium protection against damaging transients and surge currents, particularly in Type 1 and Type 2 locations. The innovative design allows for installation either on the line or load of the service panels and removes the need for circuit breakers (B Version Only). With a 120 kA per phase surge rating,

Features

- Excellent clamping and low UL voltage protection ratings
- Features relay alarming for power/phase loss and status of SPD health
- Design allows for easy removal and replacement of surge modules via lever assist
- RS-485 Interface Standard
- Up to 53 dB attenuation (10 kHz to 100 MHz)
- 10 Year Warranty

nVent ERICO DTX120 is well suited for category C locations and is typically used in applications including service entrances, distribution, branch panels, MCC, lighting panels, HVAC, and more. The nVent ERICO DTX120 also features a NEMA®-4X enclosure rating, making it suitable for outdoor applications.

Part Number	DTX120 F120240SP	DTX120 F120240HD	DTX120 F208Y	DTX120 F240D	DTX120 F480D	DTX120 F480Y
Nominal System Voltage (U _n)	120/240 V	120/240 V	120/208 V	240 VAC	480 V	277/480 V
Max Continuous Operating Voltage (U _c)	150/300 VAC	150/275 VAC	150/300 VAC	275 VAC	510 VAC	350/700 VAC
Distribution System	1Ph 3W+G	3PhΔ 4W+G	3Ph 4W+G	3PhΔ 3W+G	3PhΔ 3W+G	3Ph 4W+G
Protection Modes	L-N, L-PE, N-PE	L-N, L-PE, N-PE	L-N, L-PE, N-PE	L-PE	L-PE	L-N, L-PE, N-PE
Frequency	50–60 Hz					
Short Circuit Current Rating (SCCR)	200 kA					
Nominal Discharge Current (I _n), UL	20 kA 8/20 μs					
Max Discharge Current (I _{max}), Per Phase	120 kA 8/20 μs					
Impulse Current (I _{imp}), Per Mode	12.5 kA 10/350 μs					
Filtering	–29 dB @ 100 kHz					
Voltage Protection Rating (VPR), L-G	700 V	1,200 V	700 V	1,000 V	1,800 V	1,200 V
Voltage Protection Rating (VPR), L-L	1,000 V	1,500 V	1,200 V	1,000 V	1,800 V	2,000 V
Voltage Protection Rating (VPR), L-N	700 V	800 V	700 V	–	–	1,200 V
Voltage Protection Rating (VPR), N-G	700 V	1,500 V	600 V	–	–	1,200 V
Status Indication	Audible alarm with silence switch. Dual color status LED, Mechanical flag, OLED Display, Resettable Surge/TOV Counter					
Technology	Hybrid technology utilizing thermal disconnects					
Remote Contacts	Yes (Form C)					
Temperature	–40 to 80°C					
Mounting	4 Screw Locations					
Enclosure Rating	NEMA 4X; UL 50E Type 4					
Enclosure Material	Metal with PC Lid					
Certification Details	CSA C22.2 No. 269.2;UL® 1283 Edition 7;UL® 1449 Edition 5 Type 2, 20 kA Mode					
Complies With	ANSI/IEEE® C62.41.2-2002 Cat A, Cat B, Cat C;ANSI/IEEE® C62.41.1-2002 Cat A, Cat B, Cat C; ANSI/IEEE® C62.45-2002 Cat A, Cat B, Cat C;Mil-Std 220A					
Unit Weight	6.4 lb	5.95 lb	6.3 lb	6.15 lb	6.35 lb	6.78 lb
Dimensions H x D x W	33.1 cm x 9.8 cm x 10.2 cm					
Lead Size	2.5 mm ² –16 mm ²					
Replacement Module	DT2180DTXM	DT2180DTXM DT2275DTXM	DT2150DTXM	DT2275DTXM	DT2510DTXM	DT2350M

DT Panel Protector, 120 kA, TT version

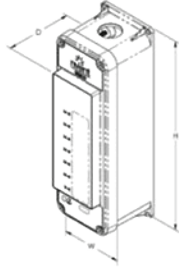

The nVent ERICO DTX120 Series of Surge Protective Devices (SPD) features Worldwide standards compliance and provides premium protection against damaging transients and surge currents, particularly in IEC Class I & Class II and UL Type 1 & Type 2 locations. The innovative design allows for installation on the line or load of the service panels and removes the need

Features

- Excellent clamping and low UL voltage protection ratings
- Features relay alarming for power/phase loss and status of SPD health
- Design allows for easy removal and replacement of surge modules via lever assist
- RS-485 Interface Standard
- Up to 53 dB attenuation (10 kHz to 100 MHz), F Version Only
- 10-Year Warranty

for circuit breakers (B Version Only). With a 120 kA per phase surge rating, DTX120 is well suited for category C locations. It is typically used in applications including service entrances, distribution, branch panels, MCC, lighting panels, HVAC, and more. The nVent ERICO DTX120 also features a NEMA®-4X enclosure rating, making it suitable for outdoor applications.

Part Number	DTX120B400TT/DTX120F400TT
Nominal System Voltage (U_n)	230/400 V
Max Continuous Operating Voltage (U_c)	300/520 VAC
Distribution System	3Ph 4W+G
Protection Modes	L-N, L-PE, N-PE
Frequency	50–60 Hz
Short Circuit Current Rating (I_{sc})	50 kA
Nominal Discharge Current (I_n), IEC	40 kA 8/20 μ s
Nominal Discharge Current (I_n), IEC, N-PE	100 kA 8/20 μ s
Max Discharge Current (I_{max}), N-PE	120 kA 8/20 μ s
Max Discharge Current (I_{max}), Per Phase	120 kA 8/20 μ s
Impulse Current (I_{imp}), Per Mode	17.5 kA 10/350 μ s
Impulse Current (I_{imp}), N-PE	70 kA 10/350 μ s
Filtering	–29 dB @ 100 kHz
Voltage Protection Level (U_p), IEC	1200 V @ 20 kA; 3000 V @ 100 kA
Status Indication	Audible alarm, silence switch, Dual color status LED, Mechanical flag, OLED Display, Surge, Surge/TOV Counter, Resettable
Technology	Hybrid technology utilizing thermal disconnects
Remote Contact Switching Capacity	2 A @ 240 V
Remote Contacts	Yes (Form C)
Temperature	–40 to 80°C
Mounting	4 Screw Locations
Enclosure Rating	NEMA®-4X, UL® 50E Type 4, IP 65
Enclosure Material	Metal with PC Lid
Complies With	EN 61643-11 Type 2, IEC® 61643-11 Class II, ANSI®/IEEE® C62.41.2-2002 Cat A, Cat B, Cat C, ANSI®/IEEE® C62.41.1-2002 Cat A, Cat B, Cat C, ANSI®/IEEE® C6.45-2002 Cat A, Cat B, Cat C
Unit Weight	3.27 kg
Dimensions H x D x W	330.2 mm x 114.3 mm x 101.6 mm
Lead Size	2 mm ² –13 mm ²
Replacement Module	DT1300M, SGT1100M

DT Panel Protector (B), 240 kA

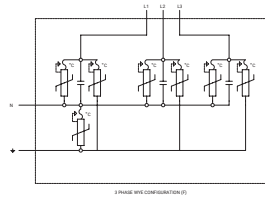

Features

- Excellent clamping and low UL voltage protection ratings
- Features relay alarming for power/phase loss and status of SPD health
- Design allows for easy removal and replacement of surge modules via lever assist
- RS-485 Interface Standard
- 10 Year Warranty



The nVent ERICO DTX240 Series of Surge Protective Devices (SPD) features a cUL 1449 listing and provides premium protection against damaging transients and surge currents, particularly in Type 1 and Type 2 locations. The innovative design allows for installation either on the line or load of the service panels and removes the need for circuit breakers (B Version Only). With a 240 kA per phase surge rating,

nVent ERICO DTX240 is well suited for category C locations and is typically used in applications including service entrances, distribution, branch panels, MCC, lighting panels, HVAC, and more. The nVent ERICO DTX240 also features a NEMA®-4X enclosure rating, making it suitable for outdoor applications.

Part Number	DTX240 B120240SP	DTX240 B120240HD	DTX240 B208Y	DTX240 B240D	DTX240 B480D	DTX240 B480Y
Nominal System Voltage (U _n)	120/240 V	120/240 V	120/208 V	240 VAC	480 V	277/480 V
Max Continuous Operating Voltage (U _c)	150/300 VAC	150/275 VAC	150/300 VAC	275 VAC	510 VAC	350/700 VAC
Distribution System	1Ph 3W+G	3PhΔ 4W+G	3Ph 4W+G	3PhΔ 3W+G	3PhΔ 3W+G	3Ph 4W+G
Protection Modes	L-N, L-PE, N-PE	L-N, L-PE, N-PE	L-N, L-PE, N-PE	L-PE	L-PE	L-N, L-PE, N-PE
Frequency	50–60 Hz					
Short Circuit Current Rating (SCCR)	200 kA					
Nominal Discharge Current (I _n), UL	20 kA 8/20 μs					
Max Discharge Current (I _{max}), Per Phase	240 kA 8/20 μs					
Impulse Current (I _{imp}), Per Mode	12.5 kA 10/350 μs					
Voltage Protection Rating (VPR), L-G	700 V	1,200 V	700 V	1,000 V	1,800 V	1,200 V
Voltage Protection Rating (VPR), L-L	1000 V	1,500 V	1,200 V	1,000 V	1,800 V	1,800 V
Voltage Protection Rating (VPR), L-N	600 V	800 V	700 V	–	–	1,200 V
Voltage Protection Rating (VPR), N-G	600 V	1,500 V	700 V	–	–	1,200 V
Status Indication	Audible alarm with silence switch. Dual color status LED, Mechanical flag, OLED Display, Resettable Surge/TOV Counter					
Technology	Hybrid technology utilizing thermal disconnects					
Remote Contacts	Yes (Form C)					
Temperature	–40 to 80°C					
Mounting	8 Screw Locations					
Enclosure Rating	NEMA 4X; UL 50E Type 4					
Enclosure Material	Metal with PC Lid					
Certification Details	CSA C22.2 No. 269.2; UL® 1449 Edition 5 Type ½, 20 kA Mode					
Complies With	ANSI®/IEEE® C62.41.2-2002 Cat A, Cat B, Cat C; ANSI®/IEEE® C62.41.1-2002 Cat A, Cat B, Cat C; ANSI®/IEEE® C62.45-2002 Cat A, Cat B, Cat C					
Unit Weight	10.98 lb	11.86 lb	11.86 lb	11.42 lb	11.68 lb	12.02 lb
Dimensions H x D x W	33.1 cm x 9.8 cm x 22.3 cm					
Lead Size	2.5 mm ² –16 mm ²					
Replacement Module	DT2180DTXM	DT2180DTXM DT2275DTXM	DT2150DTXM	DT2275DTXM	DT2510DTXM	DT2350M

DT Panel Protector (F), 240 kA

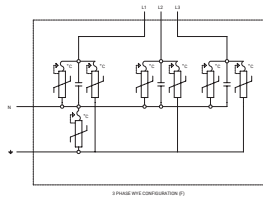

Features

- Excellent clamping and low UL voltage protection ratings
- Features relay alarming for power/phase loss and status of SPD health
- Design allows for easy removal and replacement of surge modules via lever assist
- RS-485 Interface Standard
- Up to 53 dB attenuation (10 kHz to 100 MHz)
- 10 Year Warranty



The nVent ERICO DTX240 Series of Surge Protective Devices (SPD) features a cUL 1449 listing and provides premium protection against damaging transients and surge currents, particularly in Type 1 and Type 2 locations. The innovative design allows for installation either on the line or load of the service panels and removes the need for circuit breakers (B Version Only). With a 240 kA per phase surge rating,

nVent ERICO DTX240 is well suited for category C locations and is typically used in applications including service entrances, distribution, branch panels, MCC, lighting panels, HVAC, and more. The nVent ERICO DTX240 also features a NEMA®-4X enclosure rating, making it suitable for outdoor applications.

Part Number	DTX240 F120240SP	DTX240 F120240HD	DTX240 F208Y	DTX240 F240D	DTX240 F480D	DTX240 F480Y
Nominal System Voltage (U _n)	120/240 V	120/240 V	120/208 V	240 VAC	480 V	277/480 V
Max Continuous Operating Voltage (U _c)	150/300 VAC	150/275 VAC	150/300 VAC	275 VAC	510 VAC	350/700 VAC
Distribution System	1Ph 3W+G	3PhΔ 4W+G	3Ph 4W+G	3PhΔ 3W+G	3PhΔ 3W+G	3Ph 4W+G
Protection Modes	L-N, L-PE, N-PE	L-N, L-PE, N-PE	L-N, L-PE, N-PE	L-PE	L-PE	L-N, L-PE, N-PE
Frequency	50–60 Hz					
Short Circuit Current Rating (SCCR)	200 kA					
Nominal Discharge Current (I _n), UL	20 kA 8/20 μs					
Max Discharge Current (I _{max}), Per Phase	240 kA 8/20 μs					
Impulse Current (I _{imp}), Per Mode	12.5 kA 10/350 μs					
Filtering	–29 dB @ 100 kHz					
Voltage Protection Rating (VPR), L-G	700 V	1,200 V	700 V	1,000 V	1,800 V	1,200 V
Voltage Protection Rating (VPR), L-L	1,200 V	1,500 V	1,200 V	1,000 V	1,800 V	1,800 V
Voltage Protection Rating (VPR), L-N	600 V	800 V	700 V	–	–	1,200 V
Voltage Protection Rating (VPR), N-G	600 V	1,500 V	700 V	–	–	1,200 V
Status Indication	Audible alarm with silence switch. Dual color status LED, Mechanical flag, OLED Display, Resettable Surge/TOV Counter					
Technology	Hybrid technology utilizing thermal disconnects					
Remote Contacts	Yes (Form C)					
Temperature	–40 to 80°C					
Mounting	8 Screw Locations					
Enclosure Rating	NEMA 4X; UL 50E Type 4					
Enclosure Material	Metal with PC Lid					
Certification Details	CSA C22.2 No. 269.2; UL® 1283 Edition 7; UL® 1449 Edition 5 Type 2, 20 kA Mode					
Complies With	ANSI®/IEEE® C62.41.2-2002 Cat A, Cat B, Cat C; ANSI®/IEEE® C62.41.1-2002 Cat A, Cat B, Cat C; ANSI®/IEEE® C62.45-2002 Cat A, Cat B, Cat C; Mil-Std 220A					
Unit Weight	10.98 lb	11.86 lb	11.86 lb	11.42 lb	11.68 lb	12.02 lb
Dimensions H x D x W	33.1 cm x 9.8 cm x 22.3 cm					
Lead Size	2.5 mm ² –16 mm ²					
Replacement Module	DT2180DTXM	DT2180DTXM DT2275DTXM	DT2150DTXM	DT2275DTXM	DT2510DTXM	DT2350M

DT Panel Protector, 240 kA, TT Version

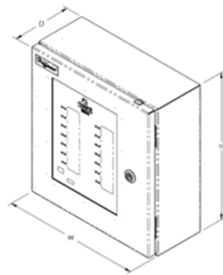

Features

- Excellent clamping and low UL voltage protection ratings
- Features relay alarming for power/phase loss and status of SPD health
- Design allows for easy removal and replacement of surge modules via lever assist
- RS-485 Interface Standard
- Up to 53 dB attenuation (10 kHz to 100 MHz), F Version Only
- 10-Year Warranty

The nVent ERICO DTX240 Series of Surge Protective Devices (SPD) features Worldwide standards compliance and provides premium protection against damaging transients and surge currents, particularly in IEC Class I & Class II and UL Type 1 & Type 2 locations. The innovative design allows for installation on the line or load of the service panels and removes the need

for circuit breakers (B Version Only). With a 240 kA per phase surge rating, DTX240 is well suited for category C locations. It is typically used in applications including service entrances, distribution, branch panels, MCC, lighting panels, HVAC, and more. The nVent ERICO DTX240 also features a NEMA®-4X enclosure rating, making it suitable for outdoor applications.

Part Number	DTX240B400TT/DTX240F400TT
Nominal System Voltage (U _n)	230/400 V
Max Continuous Operating Voltage (U _c)	300/520 VAC
Distribution System	3Ph 4W+G
Protection Modes	L-N, L-PE, N-PE
Frequency	50–60 Hz
Short Circuit Current Rating (I _{scrr})	50 kA
Nominal Discharge Current (I _n), IEC	40 kA 8/20 μs
Nominal Discharge Current (I _n), IEC, N-PE	100 kA 8/20 μs
Max Discharge Current (I _{max}), N-PE	240 kA 8/20 μs
Max Discharge Current (I _{max}), Per Phase	240 kA 8/20 μs
Impulse Current (I _{imp}), Per Mode	17.5 kA 10/350 μs
Impulse Current (I _{imp}), N-PE	70 kA 10/350 μs
Filtering	–29 dB @ 100 kHz
Voltage Protection Level (Up), IEC	1200 V @ 20 kA; 3000 V @ 100 kA
Status Indication	Audible alarm with silence switch; Dual color status LED, flashing red for faults; Mechanical flag; OLED Display; Mechanical flag; Surge/TOV Counter, Resettable
Technology	Hybrid technology utilizing thermal disconnects
Remote Contact Switching Capacity	2.0 A @ 240 V
Remote Contacts	Yes (Form C)
Temperature	–40 to 80°C
Mounting	nVent Hoffman Mounting Hardware Included
Enclosure Rating	NEMA®-4X; UL® 50E Type 4; IP66
Enclosure Material	Metal
Complies With	EN 61643-11 Type 2; IEC® 61643-11 Class II; ANSI®/IEEE® C62.41.2-2002 Cat A, Cat B, Cat C; ANSI®/IEEE® C62.41.1-2002 Cat A, Cat B, Cat C
Unit Weight	9.75 kg
Dimensions H x D x W	355.1 mm x 140.2 mm x 329.9 mm
Lead Size	2 mm ² –13 mm ²
Replacement Module	DT1300M, SGT1100M

Compact TDX Panel Protector, 50 kA

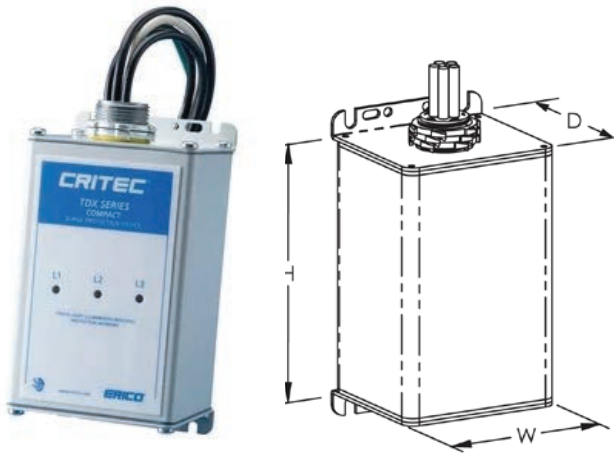

Features

- Transient Discriminating (TD) Technology provides increased service life
- Built-in features include TD Technology, thermal protection and short circuit current fusing
- Compact NEMA®-4 enclosure design can be flush mounted or installed in a small space
- LED status indication and voltage-free contacts provide remote status monitoring
- 50 kA 8/20 μ s maximum surge rating provides protection suitable for sub-distribution panels and a long operational life



Catalog Number	TDX50C120	TDX50C120/208	TDX50C120240	TDX50C120240D	TDX50C277/480	TDX50C347600
Nominal System Voltage (U_n)	120 V	120/208 V	120/240 V	120/240 V	277/480 V	347/600 V
Distribution System	1Ph 2W+G	3Ph 4W+G	1Ph 3W+G	3Ph Δ 4W+G	3Ph 4W+G	3Ph 4W+G
Max Continuous Operating Voltage (U_c)	170 VAC	170/276 VAC	170/276 VAC	170/276 VAC	320/550 VAC	550/1,100 VAC
Stand-off Voltage	240 VAC	240/415 VAC	240/480 VAC	240/415 VAC	480/831 VAC	600/1,040 VAC
Frequency	50–60 Hz					
Short Circuit Current Rating (SCCR)	200 kA					
Nominal Discharge Current (I_n), UL	10 kA 8/20 μ s					
Nominal Discharge Current (I_n), IEC	40 kA 8/20 μ s					
Max Discharge Current (I_{max}), Per Phase	50 kA 8/20 μ s					
Voltage Protection Rating (VPR), L-N	600 V @ 3 kA V 1,200 V @ 20 kA V	600 V @ 3 kA V 1,200 V @ 20 kA V	600 V @ 3 kA V 1,200 V @ 20 kA V	600 V @ 3 kA V 1,200 V @ 20 kA V	1,200 V @ 3 kA V 1,800 V @ 20 kA V	2,000 V @ 3 kA V 2,600 V @ 20 kA V
Technology	Over-current fusing TD technology with thermal disconnect					
Surge Counter	No					
Remote Contacts	Yes					
Protection Modes	L-N L-PE N-PE					
Status Indication	LED					
Lead Size	5.26 mm ²					
Lead Length	762 mm					
Temperature	–40 to 80°C					
Ground Lead Length	914 mm					
Mounting	¾" straight nipple					
Enclosure Rating	IP 65 NEMA®-4					
Enclosure Material	Metal					
Depth (D)	78 mm					
Width (W)	84 mm					
Height (H)	153 mm					
Unit Weight	0.7 kg					
Certification Details	UL® 1449 Edition 5 Type ½, 10 kA Mode					
Complies With	ANSI®/IEEE® C62.41.2-2002 Cat A, Cat B, Cat C ANSI®/IEEE® C62.41.2-2002 Scenario II, Exposure 2, 50 kA 8/20 μ s IEC® 61643-1 Class I, Class II					

TDXM Modular Series

TDX200 Transient Discriminating Panel Protection

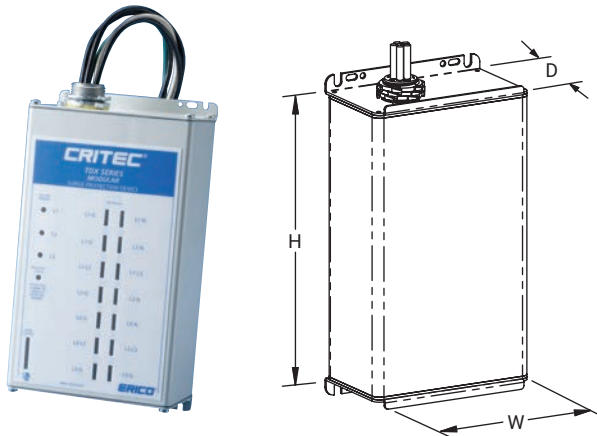

Features

- Transient Discriminating (TD) Technology provides increased service life
- Modular design allows individual modes to be field replaceable, built-in disconnect and fusing eliminates need for external fusing
- Built-in features include TD Technology, thermal protection and short circuit current cartridge fusing
- Compact NEMA®-4 enclosure design can be flush mounted or installed in a small space
- Status indication flag per mode, voltage presence LED's, audible alarm and voltage-free contacts providing remote status monitoring
- 200 kA 8/20 μ s maximum surge rating provides protection suitable for service entrance, main-distribution panels and highly exposed applications
- Available in various operating voltages to suit most common power distribution systems
- CE, UL® 1449 Edition 5 Listed, CSA-22.2 (347/600 V model)
- 'S' Versions of the TDX200 include a surge counter and a surge filter

The TDX200 Series of Transient Voltage Surge Suppressors is designed for critical protection applications. The 200 kA 8/20 μ s of surge protection exceeds the IEEE® C62.41.2 Scenario II single shot surge rating requirements for exposed service entrance locations – Exposure 3.

The NEMA-4 weather-tight housing allows the TDX to be installed on indoor or outdoor service panels. The preconfigured connecting leads simplify installation.

The unique narrow construction allows the SPD to fit between adjacent panel boards and connect via a 90-degree elbow. A flush mounting kit (p/n TDXM200FP) is also available for installing the SPD in drywall applications. A side mount kit (p/n TDXSM) is also available.

Listed as a Type 1 SPD to UL 1449 Edition 5, the TDX200 Series can be installed within a Type 1 or 2 location in accordance with the NEC® 2017

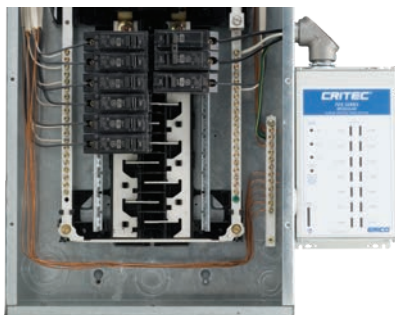

Typical Installation



TDX200M Enclosure



TDX Replaceable Modules



TDX Replaceable Module backplane fully removed

TDXM Modular Series

TDX200 Transient Discriminating Panel Protection

Part Number	TDX200M 120/208	TDX200M 120/240	TDX200M 277/480	TDX200M 347/600	TDX200M 120/240D	TDX200M 240D	TDX200M 480D	TDX200M 277480TT	TDX200S 277480T
Nominal System Voltage (U _n)	120/208 V	120/240 V	277/480 V	347/600 V	120/240 V	240 VAC	480 V	277/480 V	
Distribution System	3Ph 4W+G	1Ph 3W+G	3Ph 4W+G		3PhΔ 4W+G	3PhΔ 3W+G		3Ph 4W+G (suitable for TT system)	
Max Continuous Operating Voltage (U _c)	170/276 VAC		320/550 VAC	550/1100 VAC	170/276 VAC	276 VAC	550 VAC	320/550 VAC	
Stand-off Voltage	240/415 VAC	240/480 VAC	480/831 VAC	790/1370 VAC	240/415 VAC	415 VAC	790 VAC	480/831 VAC	
Frequency	50–60 Hz								
Short Circuit Current Rating (SCCR)	200 kA								
Nominal Discharge Current (I _n), IEC	40 kA 8/20 μs							80 kA 8/20 μs	40 kA 8/20 μs
Nominal Discharge Current (I _n), UL	20 kA 8/20 μs								
Max Discharge Current (I _{max}), Per Phase	200 kA 8/20 μs								
Impulse Current (I _{imp}), Per Mode	25 kA 10/350 μs								
Voltage Protection Rating (VPR)	600 V @ 3 kA L-N 1,200 V @ 20 kA L-N		1,000 V @ 3 kA L-N 1,800 V @ 20 kA L-N	1,800 V @ 3 kA L-N 2,600 V @ 20 kA L-N	600 V @ 3 kA L-N 1,200 V @ 20 kA L-N	1,000 V @ 3 kA L-L 1,800 V @ 20 kA L-L	1,800 V @ 3 kA L-L 2,600 V @ 20 kA L-L	1000 V @ 3 kA L-N V; 1800 V @ 20 kA L-N V	
Filtering (S Option)	-40 dB @ 100 kHz								
Protection Modes	L-N L-PE N-PE							L-N; N-PE	L-N; N-PE
Status Indication	LED; Mechanical flag; Audible alarm								
Surge Counter	Yes, S version							No	Yes
Technology	TD technology with thermal disconnect; Over-current replaceable cartridge fusing; EMI/RFI filter								
Remote Contacts	Yes								
Lead Length	76.2 cm								
Lead Size	6 mm ²							5.26 mm ²	
Ground Lead Length	91.4 cm								
Temperature	-40 to 80°C								
Enclosure Material	Metal								
Enclosure Rating	IP 65 NEMA®-4								
Mounting	¾" straight nipple								
Dimensions H x D x W	24.0 cm x 7.8 cm x 13.0 cm								
Unit Weight	2.00 kg								
Certification Details	UL® 1449 Edition 5 Type ½, 20 kA Mode							-	-
Complies With	ANSI®/IEEE® C62.41.2-2002 Cat A, Cat B, Cat C ANSI®/IEEE® C62.41.2-2002 Scenario II, Exposure 3, 100 kA 8/20 μs, 10 kA 10/350 μs; IEC® 61643-1 Class I, Class II								
Replacement Module	TDS150M150		TDS150M277	TDS150M560	TDS150M150 TDS150M240	TDS150M240	TDS150M560	TDS150M277 SGD125M	
Certifications	CE; C-Tick UL			CE; C-Tick; cULus	CE; C-Tick			-	-
Accessories	Flush Plate (TDXM200FP), Side Mount Kit (TDXSM), Fuse Replacement (TDXFUSE)							-	-

Delta and "S" models are Type 2 devices.

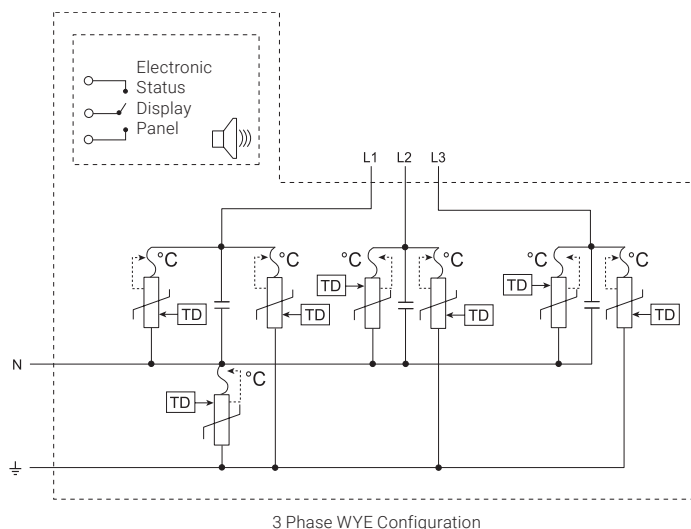

ANSI is a registered trademark of the American National Standards Institute. IEC is a registered trademark of the International Electrotechnical Commission. IEEE is a registered trademark of the Institute of Electrical and Electronics Engineers, Incorporated. NEMA is a registered trademark of the National Electrical Manufacturers Association. UL is a registered certification mark of UL LLC.

TDXM Modular Series

TDX100 Transient Discriminating Panel Protection

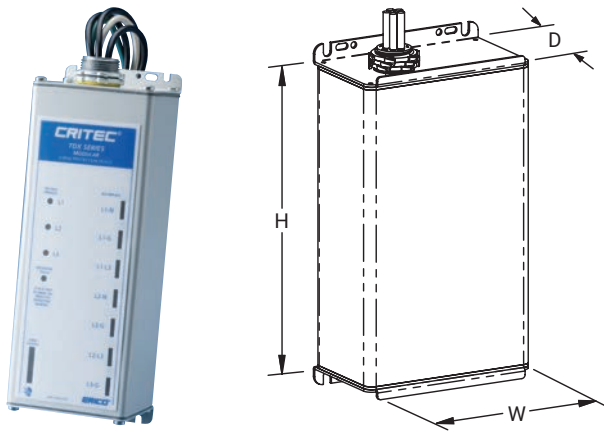

Features

- Transient Discriminating (TD) Technology provides increased service life
- Modular design allows individual modes to be field replaceable, built-in disconnect and fusing eliminates need for external fusing
- Built-in features include TD Technology, thermal protection and short circuit current cartridge fusing
- Compact NEMA®-4 enclosure design can be flush mounted or installed in a small space
- Status indication flag per mode, voltage presence LEDs, audible alarm and voltage-free contacts providing remote status monitoring
- 100 kA 8/20 μ s maximum surge rating provides protection suitable for smaller main-distribution panels and an extended operational life
- Available in various operating voltages to suit most common power distribution systems
- CE, UL® 1449 Edition 5 Listed, CSA-22.2 (347/600 V model)
- 'S' Versions of the TDX100 include a surge counter and a surge filter

The TDX100 Series of Transient Voltage Surge Suppressors is designed for critical protection applications. The 100 kA 8/20 μ s of surge protection meets the IEEE® C62.41.2 Scenario II single shot surge rating requirements for exposed service entrance locations – Exposure 3.

The NEMA-4 weather tight housing allows the TDX to be installed on indoor or outdoor service panels. The preconfigured connecting leads simplify installation. The unique narrow construction allows the SPD to fit between

adjacent panel boards and connect via a 90-degree elbow. A flush mounting kit (p/n TDXM100FP) is also available for installing the SPD in drywall applications. A side mount kit (p/n TDXSM) is also available.

Listed as a Type 1 SPD to UL 1449 Edition 5, the TDX100 Series can be installed within a Type 1 or 2 location in accordance with the NEC® 2017.



Typical Installation



Output contacts



TDX Replaceable Cartridge overcurrent fuse protection



TDX Replaceable Modules

TDXM Modular Series

TDX100 Transient Discriminating Panel Protection

Part Number	TDX100M 120/208	TDX100M 120/240	TDX100M 277/480	TDX100M 347/600	TDX100M 120/240D	TDX100M 240D	TDX100M 480D	TDX100M 277/480TT	TDX100S 277/480T	
Nominal System Voltage (U _n)	120/208 V	120/240 V	277/480 V	347/600 V	120/240 V	240 VAC	480 V	277/480 V	277/480 V	
Distribution System	3Ph 4W+G	1Ph 3W+G	3Ph 4W+G	3Ph 4W+G	3PhΔ 4W+G	3PhΔ 3W+G	3Ph 3W+G	3Ph 4W+G (suitable for TT system)		
Max Continuous Operating Voltage (U _c)	170/276 VAC		320/550 VAC		550/1100 VAC	170/276 VAC	276 VAC	550 VAC	320/550 VAC	
Stand-off Voltage	240/415 VAC	240/480 VAC	480/831 VAC	790/1370 VAC	240/415 VAC	415 VAC	790 VAC	480/831 VAC		
Frequency	50–60 Hz									
Short Circuit Current Rating (SCCR)	200 kA									
Nominal Discharge Current (I _n), IEC	40 kA 8/20 μs									
Nominal Discharge Current (I _n), UL	20 kA 8/20 μs									
Max Discharge Current (I _{max}), Per Phase	100 kA 8/20 μs									
Impulse Current (I _{imp}), Per Mode	12.5 kA 10/350 μ									
Voltage Protection Rating (VPR), L-L	1,000 V	1,000 V	1,800 V	4,000 V	1,800 V	1,000 V @ 3 kA 1,800 V @ 20 kA	1,800 V @ 3 kA 2,600 V @ 20 kA	–	25 V	
Voltage Protection Rating (VPR), L-N	600 V @ 3 kA 1,200 V @ 20 kA		1,200 V @ 3 kA 1,800 V @ 20 kA	1,800 V @ 3 kA 2,600 V @ 20 kA	600 V @ 3 kA 1,200 V @ 20 kA	–	–	1,200 V @ 3 kA V; 1,800 V @ 20 kA V		
Filtering (S Option)	–40 dB @ 100 kHz									
Protection Modes	L-N L-PE N-PE								L-N; N-PE	
Status Indication	LED, Mechanical flag, Audible alarm									
Surge Counter	Yes, S version								No	Yes
Technology	TD technology with thermal disconnect; Over-current replaceable cartridge fusing; EMI/RFI filter (S versions)									
Remote Contacts	Yes									
Lead Length	76.2 cm									
Lead Size	6 mm ²								5.26 mm ²	
Ground Lead Length	91.4 cm									
Temperature	–40 to 80°C									
Enclosure Material	Metal									
Enclosure Rating	IP 65 NEMA®-4									
Mounting	¾" straight nipple									
Dimensions H x D x W	24.0 cm x 7.8 cm x 8.4 cm									
Unit Weight	1.41 kg									
Certification Details	UL® 1449 Edition 5 Type 2, 20 kA Mode							UL® 1449 Edition 5 Type ½, 20 kA Mode	UL® 1449 Edition 5 Type 2, 20 kA Mode	
Complies With	ANSI®/IEEE® C62.41.2-2002 Cat A, Cat B, Cat C ANSI®/IEEE® C62.41.2-2002 Scenario II, Exposure 3, 100 kA 8/20 μs, 10 kA 10/350 μs; IEC® 61643-1 Class I, Class II									
Replacement Module	TDS150M150		TDS150M277	TDS150M560	TDS150M150 TDS150M240	TDS150M240	TDS150M560	TDS150M277 SGD125M		
Accessories	Flush Plate (TDXM100FP), Side Mount Kit (TDXSM), Fuse Replacement (TDXFUSE)							–	–	

Delta and "S" models are Type 2 devices.

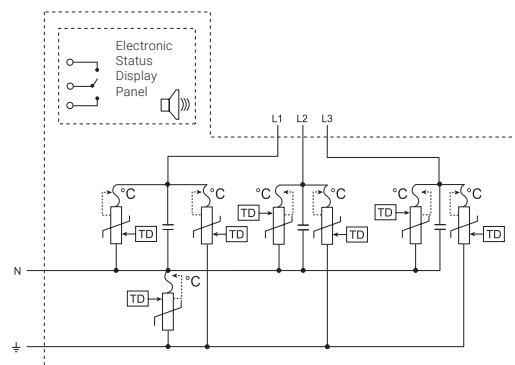

3 Phase WYE Configuration

ANSI is a registered trademark of the American National Standards Institute. IEC is a registered trademark of the International Electrotechnical Commission. IEEE is a registered trademark of the Institute of Electrical and Electronics Engineers, Incorporated. NEMA is a registered trademark of the National Manufacturers Association. UL is a registered certification mark of UL LLC.

TDXM Modular Series

TDX400S Transient Discriminating Panel Protection

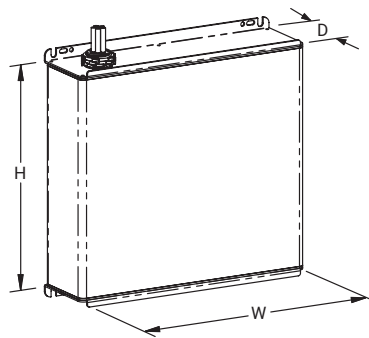

Features

- Transient Discriminating (TD) Technology provides increased service life
- Modular design allows individual modes to be field replaceable, built-in disconnect and fusing eliminates need for external fusing
- Built-in features include TD Technology, thermal protection, short circuit current cartridge fusing and a surge counter
- Status indication flag per mode, voltage presence LED's, audible alarm, surge counter, and voltage-free contacts providing remote status monitoring
- Available in various operating voltages to suit most common power distribution systems
- 400 kA 8/20 μ s maximum surge rating provides protection suitable for service entrance, main-distribution panels and highly exposed applications
- CE, UL® 1449 Edition 5 Listed

The TDX400 Series of Transient Voltage Surge Suppressors is designed for critical protection applications. The 400 kA 8/20 μ s of surge protection exceeds the IEEE® C62.41.2 Scenario II single shot surge rating requirements for exposed service entrance locations – Exposure 3.

The NEMA®-12/3R weather-tight housing.

The preconfigured connecting leads simplify installation. The unique narrow construction allows the SPD to fit between adjacent panel boards and connect via a 90-degree elbow.

Listed as a Type 1 SPD to UL 1449 Edition 5, the TDX400 Series can be installed within a Type 1 or 2 location in accordance with the NEC® 2017, Article 285.

Part Number	TDX400S120/208	TDX400S120/240	TDX400S277/480
Nominal System Voltage (Un)	120/208 V	120/240 V	277/480 V
Distribution System	3Ph 4W+G	1Ph 3W+G	3Ph 4W+G
Max Continuous Operating Voltage (Uc)	170/276 VAC		320/550 VAC
Stand-off Voltage	240/415 VAC	240/480 VAC	480/831 VAC
Frequency	50–60 Hz		
Short Circuit Current Rating (SCCR)	200 kA		
Nominal Discharge Current (In), IEC	40 kA 8/20 μ s		
Nominal Discharge Current (In), UL	20 kA 8/20 μ s		
Max Discharge Current (Imax), Per Phase	400 kA 8/20 μ s		
Impulse Current (Iimp), Per Mode	25 kA 10/350 μ s		
Voltage Protection Rating (VPR), L-N	800 V @ 3 kA		1,200 V @ 3 kA
Protection Modes	L-N L-PE N-PE		
Status Indication	LED, Mechanical flag Audible alarm		
Surge Counter	Yes		
Technology	TD technology with thermal disconnect Over-current replaceable cartridge fusing		
Remote Contacts	Yes		
Lead Length	76.2 cm		
Lead Size	6 mm ²		
Ground Lead Length	91.4 cm		
Temperature	-40 to 80°C		
Enclosure Material	Metal		
Enclosure Rating	IP 20 NEMA®-12/3R		
Mounting	¾" straight nipple		
Dimensions H x D x W	26.4 cm x 8.3 cm x 26.2 cm		
Unit Weight	6.4 kg		
Certification Details	UL® 1449 Edition 5 Type ½, 20 kA Mode		
Complies With	ANSI®/IEEE® C62.41.2-2002 Scenario II, Exposure 3, 100 kA 8/20 μ s, 10 kA 10/350 μ s IEC® 61643-1 Class I, Class II		
Replacement Module	TDS150M150		TDS150M277

ANSI is a registered trademark of the American National Standards Institute. IEC is a registered trademark of the International Electrotechnical Commission. IEEE is a registered trademark of the Institute of Electrical and Electronics Engineers, Incorporated. NEMA is a registered trademark of the National Electrical Manufacturers Association. UL is a registered certification mark of UL LLC.

TDXM Modular Series

TDX300S Transient Discriminating Panel Protection

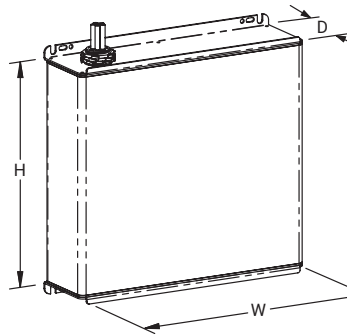

Features

- Transient Discriminating (TD) Technology provides increased service life
- Modular design allows individual modes to be field replaceable, built-in disconnect and fusing eliminates need for external fusing
- Built-in features include TD Technology, thermal protection, short circuit current cartridge fusing and surge counter
- Status indication flag per mode, voltage presence LED's, audible alarm surge counter and voltage-free contacts providing remote status monitoring
- Available in various operating voltages to suit most common power distribution systems
- 300 kA 8/20 μ s maximum surge rating provides protection suitable for service entrance, main-distribution panels and highly exposed applications
- CE, UL® 1449 Edition 5 Listed

The TDX300 Series of Transient Voltage Surge Suppressors is designed for critical protection applications. The 300 kA 8/20 μ s of surge protection exceeds the IEEE® C62.41.2 Scenario II single shot surge rating requirements for exposed service entrance locations – Exposure 3.

The NEMA®-12/3R weather-tight housing.

The preconfigured connecting leads simplify installation. The unique narrow construction allows the SPD to fit between adjacent panel boards and connect via a 90-degree elbow.

Listed as a Type 1 SPD to UL 1449 Edition 5, the TDX300 Series can be installed within a Type 1 or 2 location in accordance with the NEC® 2017.

Part Number	TDX300S120/208	TDX300S120/240	TDX300S277/480
Nominal System Voltage (U_n)	120/208 V	120/240 V	277/480 V
Distribution System	3Ph 4W+G	1Ph 3W+G	3Ph 4W+G
Max Continuous Operating Voltage (U_c)	170/276 VAC		320/550 VAC
Stand-off Voltage	240/415 V	240/480 V	480/831 V
Frequency	50–60 Hz		
Short Circuit Current Rating (SCCR)	200 kA		
Nominal Discharge Current (I_n), IEC	40 kA 8/20 μ s		
Nominal Discharge Current (I_n), UL	20 kA 8/20 μ s		
Max Discharge Current (I_{max}), Per Phase	300 kA 8/20 μ s		
Impulse Current (I_{imp}), Per Mode	23 kA 10/350 μ s		
Voltage Protection Rating (VPR), L-N	800 V @ 3 kA		1,200 V @ 3 kA
Protection Modes	L-N L-PE N-PE		
Status Indication	LED, Mechanical flag Audible alarm		
Surge Counter	Yes		
Technology	TD technology with thermal disconnect Over-current replaceable cartridge fusing		
Remote Contacts	Yes		
Lead Length	76.2 cm		
Lead Size	6 mm ²		
Ground Lead Length	91.4 cm		
Temperature	-40 to 80°C		
Enclosure Material	Metal		
Enclosure Rating	IP 20 NEMA®-12/3R		
Mounting	¾" straight nipple		
Dimensions H x D x W	26.4 cm x 8.3 cm x 26.2 cm		
Unit Weight	5.9 kg		
Certification Details	UL® 1449 Edition 5 Type ½, 20 kA Mode		
Complies With	ANSI®/IEEE® C62.41.2-2002 Scenario II, Exposure 3, 100 kA 8/20 μ s, 10 kA 10/350 μ s IEC® 61643-1 Class I, Class II		
Replacement Module	TDS150M150		TDS150M277

ANSI is a registered trademark of the American National Standards Institute. IEC is a registered trademark of the International Electrotechnical Commission. IEEE is a registered trademark of the Institute of Electrical and Electronics Engineers, Incorporated. NEMA is a registered trademark of the National Electrical Manufacturers Association. UL is a registered certification mark of UL LLC.

DT and EDT SPD Features

Packed with features and benefits for the user, the DT and EDT line from nVent ERICO represents the latest in product design, development and testing.



SPD STATUS INDICATION



ALARM CONTACTS ALLOW REMOTE STATUS MONITORING

ADVANCED DESIGN AVOIDS FUSING IN MANY INSTALLATIONS



CLIP LOCKS MODULE IN PLACE FOR VIBRATION RESISTANCE



CONVENIENT MODULE AND BASE DESIGN

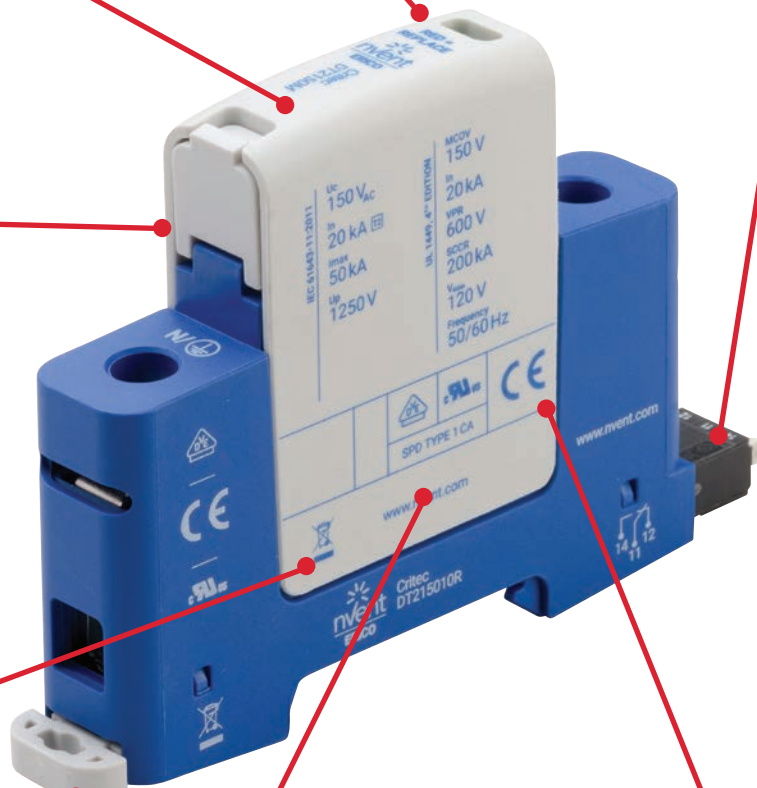

LOCK BACK CLIP MAKES FOR EASY INSTALLATION



KEYING MECHANISM ENSURES CORRECT MODULE



RUGGED CONNECTION TO BASE HANDLES HIGH SURGE CURRENT

DT1M DIN Rail Surge Protection Class I+II 25 kA

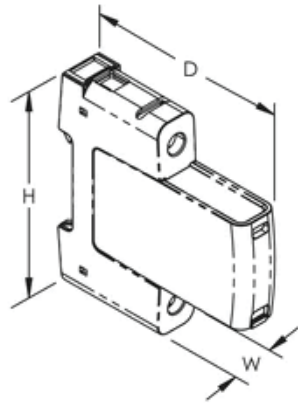

Features

- Spark gap surge performance with MOV-like current extinction
- Universally coordinated with any Class II or Class III surge protection devices
- Follow current limitation, no tripping of a 16 A gG fuse
- Compact, yet high surge rated pluggable design, using minimum DIN rail width
- Retaining clip ensures enhanced vibration and shock resistance performance
- Red/Green status indication and change-over contacts standard for remote monitoring
- Includes thermal disconnect for safe end of life

Catalog Number	DT1M27510R	DT1M27530R	DT1M27531R	DT1M27540R
Nominal System Voltage (U_n)	240 VAC	220/380 - 240/415 VAC	220/380 - 240/415 VAC	220/380 - 240/415 VAC
Nominal Discharge Current (I_n), IEC, L-N				
Nominal Discharge Current (I_n), IEC, N-PE			100 kA 8/20 μ s	
Nominal Discharge Current (I_n), IEC	25 kA 8/20 μ s			
Max Continuous Operating Voltage (U_c)	275 VAC	275 VAC	275 VAC L-N 305 VAC N-PE	275 VAC
Max Discharge Current (I_{max}), IEC, L-N				
Max Discharge Current (I_{max}), IEC, N-PE			150 kA 8/20 μ s	
Max Discharge Current (I_{max}), IEC	65 kA 8/20 μ s			
Impulse Current (I_{imp})	25 kA 10/350 μ s	25 kA 10/350 μ s	25 kA 10/350 μ s 100 kA 10/350 μ s	25 kA 10/350 μ s
Voltage Protection Level (U_p)	1500 V	1550 V		1550 V
Voltage Protection Level (U_p), L-N			1800 V	
Voltage Protection Level (U_p), N-PE			1500 V	
Frequency	50 – 60 Hz			
Response Time	100 ns max			
Back-Up Fuse @ I_{sc}	315 A @ 50 kA A			
Short Circuit Current Rating (I_{sc})	50 kA			
Protection Modes	L-N L-PE L-PEN N-PE (TN-S)	L-PEN	L-N N-PE	L-PE N-PE
Distribution System	TN-C TN-S TT (L-N)	TN-C	TN-S TT	TN-S
Follow Current Interrupt Rating (I_{fi})	50 kA	50 kA	50 kA 100 kA	50 kA
Temporary Over Voltage 120 min (U_t /mode)	442 V Withstand			
Temporary Over Voltage 120 min (U_t /mode), L-N				
Temporary Over Voltage Withstand 200 ms (U_t), N-PE			1200 V	
Technology	Thermal Disconnect			
Torque (TQ)	4.5 N·m			
Connection, Solid	35 mm ² max			
Connection, Stranded	25 mm ² max			
Humidity	5–95			
Altitude	2000 m max			
Temperature	-40 to 70°C			
Mounting	35 mm top hat DIN rail			
Enclosure Rating	IP 20			
Enclosure Material	UL® 94 V-0 Thermoplastic			
Remote Contacts	Yes			
Status Indication	Mechanical flag			
Remote Contact Switching Capacity	1 A @ 250 VAC A 1 A @ 125 VAC A 0.5 A @ 48 VDC A 0.5 A @ 24 VDC A 0.5 A @ 12 VDC A			
Depth (D)	85 mm			
Width (W)	18 mm			
Height (H)	90 mm			
Unit Weight	0.18 kg	0.51 kg	0.69 kg	0.68 kg
Replacement Module	DT1M275M	DT1M275M	DT1M27531M SGT1100M	DT1M275M
Complies With	EN 61643-11 Type 1, Type 2 IEC® 61643-11 Class I, Class II			

DT1 DIN Rail Surge Protection IEC Class I+II, 1+0 Mode

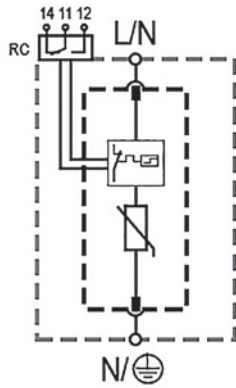

Features

- Compact, yet high surge rated pluggable design, using minimum DIN rail width
- Retaining clip ensures enhanced vibration and shock resistance performance
- Red/Green status indication and change-over contacts standard for remote monitoring

Certification Details: IEC 61643-11 Class I+II, EN 61643-11 Type 1+2, UL 1449, 5th Edition Type 1CA

Complies with: IEC 61643-11:2011, EN 61643-11:2012, UL 1449, 5th Edition, CSA C22.2 No. 269-4

Protection Modes: L-PE, N-PE (only TN-S), L-PE/N, L-N, L-L



Part Number	DT17510R	DT115010R	DT130010R	DT135010R	DT148010R	DT175010R
UL Electrical						
UL Nominal Voltage	60 V	120 V	240 V	277 V	400 V	600 V
Maximum Continuous Operating Voltage (AC) MCOV	75 V	150 V	300 V	350 V	480 V	750 V
Voltage Protection Rating VPR	330 V	500 V	900 V	1,200 V	1,500 V	2,500 V
Nominal Discharge Current (8/20 μs) I _n	20 kA	20 kA	20 kA	20 kA	20 kA	20 kA
Short-Circuit Current Rating (AC) SCCR	100 kA	200 kA	150 kA	150 kA	200 kA	150 kA
IEC Electrical						
Nominal AC Voltage (50/60Hz) U _c /U _n	60 V	120 V	240 V	277 V	400 V	600 V
Maximum Continuous Operating Voltage (AC) U _c	75 V	150 V	300 V	350 V	480 V	750 V
Nominal Discharge Current (8/20 μs) I _n	20 kA					
Maximum Discharge Current (8/20 μs) I _{max}	100 kA	100 kA	100 kA	100 kA	100 kA	60 kA
Impulse Discharge Current (10/350 μs) I _{imp}	12.5 kA	12.5 kA	12.5 kA	12.5 kA	10 kA	5 kA
Specific Energy W/R	39 kJ/Ω	39 kJ/Ω	39 kJ/Ω	39 kJ/Ω	25 kJ/Ω	6.25 kJ/Ω
Charge Q	6.25 As	6.25 As	6.25 As	6.25 As	5 As	2.5 As
Voltage Protection Level U _p	700 V	1000 V	1400 V	1500 V	2000 V	2700 V
Response Time t _A	< 25 ns					
Back-Up Fuse (max)	315A / 250A gG					250 A gG
Short-Circuit Current Rating (AC) I _{SCCR}	25 kA / 50 kA					50 kA
TOV Withstand 5s U _T	114 V	175 V	337 V	403 V	581 V	871 V
TOV 120 min U _T /mode	114 V/ withstand	229 V/safe fail	442 V/safe fail	529 V/safe fail	762 V/safe fail	1143 V/safe fail
Number of Ports	1					
Mechanical						
Operating Temperature Range T _a	-31°F to 185°F (-35°C to 85°C)					
Permissible Operating Humidity RH	5%...95%					
Altitude	6562 ft [2000 m]					
Terminal Screw Torque M _{max}	39.9 lbf-in [4.5 Nm]					
Conductor Cross Section (max)	35 mm ² (Solid) / 25 mm ² (Stranded) , 2 AWG (Solid)/4 AWG (Stranded)					
Mounting	35 mm DIN Rail, EN 60715					
Degree of Protection	IP 20					
Housing Material	Thermoplastic: Extinguishing Degree UL 94 V-0					
Thermal Protection	Yes					
Operating State/Fault Indication	Green Flag / Not Green Flag					
Remote Contacts (RC)	Yes					
RC Switching Capacity	AC: 250 V/1 A, 125 V/1 A; DC: 48 V/0.5 A, 24 V/0.5 A, 12 V/0.5 A					
RC Conductor Cross Section (max)	1.5 mm ² (Solid)/16 AWG (Solid)					
Single Unit Weight pounds	0.371	0.371	0.402	0.437	0.446	0.452
Single Unit Weight grams	168	168	182	198	202	205

*Other voltages and configurations available upon request

DT1 DIN Rail Surge Protection IEC Class I+II, 2+0 Mode

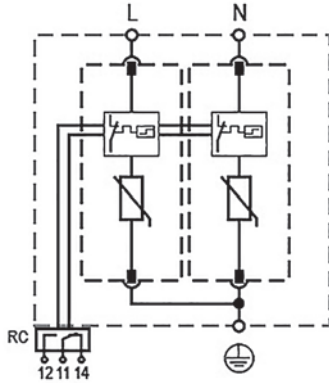

Features

- Compact, yet high surge rated pluggable design, using minimum DIN rail width
- Retaining clip ensures enhanced vibration and shock resistance performance
- Red/Green status indication and change-over contacts standard for remote monitoring

Certification Details:	IEC 61643-11 Class I+II EN 61643-11 Type 1+2 UL 1449, 5th Edition Type 1CA
Complies with:	IEC 61643-11:2011 EN 61643-11:2012 UL 1449, 5th Edition CSA C22.2 No. 269-4
Protection Modes:	L-PE, N-PE, L-L



Part Number	DT115020R	DT130020R	DT135020R	DT175020R
UL Electrical				
UL Nominal Voltage	240/120 V 1S 208/120 V 3Y	415/240 V 3Y 240V 3D	480/277 V 3Y 240 V 3D	347/600 V 3Y
Maximum Continuous Operating Voltage (AC) MCOV	150 V/300 V	300 V/600 V	350 V/700 V	750 V/1,500 V
Voltage Protection Rating VPR	500 V/1,000 V	900 V/1,800 V	1,200 V/2,000 V	2,500 V/5,000 V
Nominal Discharge Current (8/20 μ s) I_n	20 kA	20 kA	20 kA	20 kA
Short-Circuit Current Rating (AC) SCCR	200 kA	150 kA	150 kA	150 kA
IEC Electrical				
Nominal AC Voltage (50/60Hz) U_o / U_n	120 V	240 V	277 V	600 V
Maximum Continuous Operating Voltage (AC) U_c	150 V	300 V	350 V	750 V
Nominal Discharge Current (8/20 μ s) I_n	20 kA			
Maximum Discharge Current (8/20 μ s) I_{max}	100 kA	100 kA	100 kA	60 kA
Impulse Discharge Current (10/350 μ s) I_{imp}	12.5 kA	12.5 kA	12.5 kA	5 kA
Specific Energy W/R	39 kJ/ Ω	39 kJ/ Ω	39 kJ/ Ω	6.25 kJ/ Ω
Charge Q	6.25 As	6.25 As	6.25 As	2.5 As
Voltage Protection Level U_p	1,000 V	1,400 V	1,500 V	2,700 V
Response Time t_a	< 25 ns			
Back-Up Fuse (max)	315A / 250A gG			250 A gG
Short-Circuit Current Rating (AC) ISCCR	25 kA / 50 kA			50 kA
TOV Withstand 5s U_T	175 V	337 V	403 V	871 V
TOV 120 min $U_{T,mode}$	229 V/safe fail	442 V/safe fail	529 V/safe fail	1,143 V/safe fail
Number of Ports	1			
Mechanical				
Operating Temperature Range T_a	-31°F to 185°F (-35°C to 85°C)			
Permissible Operating Humidity RH	5%...95%			
Altitude	6562 ft [2000 m]			
Terminal Screw Torque M_{max}	39.9 lbf·in [4.5 Nm]			
Conductor Cross Section (max)	35 mm ² (Solid)/25 mm ² (Stranded), 2 AWG (Solid)/4 AWG (Stranded)			
Mounting	35 mm DIN Rail, EN 60715			
Degree of Protection	IP 20			
Housing Material	Thermoplastic: Extinguishing Degree UL 94 V-0			
Thermal Protection	Yes			
Operating State / Fault Indication	Green Flag/Not Green Flag			
Remote Contacts (RC)	Yes			
RC Switching Capacity	AC: 250 V/1 A, 125 V/1 A; DC: 48 V/0.5 A, 24 V/0.5 A, 12 V/0.5 A			
RC Conductor Cross Section (max)	1.5 mm ² (Solid)/16 AWG (Solid)			
Single Unit Weight pounds	0.717	0.779	0.849	0.880
Single Unit Weight grams	325	353	385	399

*Other voltages and configurations available upon request

DT1 DIN Rail Surge Protection IEC Class I+II, 3+0 Mode

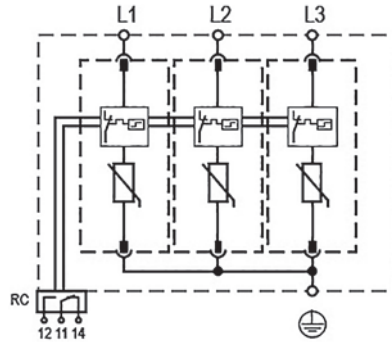

Features

- Compact, yet high surge rated pluggable design, using minimum DIN rail width
- Retaining clip ensures enhanced vibration and shock resistance performance
- Red/Green status indication and change-over contacts standard for remote monitoring

Certification Details:	IEC 61643-11 Class I+II EN 61643-11 Type 1+2 UL 1449, 5th Edition Type 1CA
Complies with:	IEC 61643-11:2011 EN 61643-11:2012 UL 1449, 5th Edition CSA C22.2 No. 269-4
Protection Modes:	L-PE, N-PE, L-L



Part Number	DT115030R	DT130030R	DT135030R	DT148030R	DT175030R
UL Electrical					
UL Nominal Voltage	208/120 V 3Y 240/120 V 1S	415/240 V 3Y 240 V 3D	480/277 V 3Y	690/400 V 3Y	600 V 3D 480 V 3D
Maximum Continuous Operating Voltage (AC) MCOV	150 V/300 V	300 V/600 V	350 V/700 V	480 V/960 V	750 V/1,500 V
Voltage Protection Rating VPR	500 V/1,000 V	900 V/1,800 V	1,200 V/2,000 V	1,500 V/3,000 V	2,500 V/5,000 V
Nominal Discharge Current (8/20 μ s) I_n	20 kA	20 kA	20 kA	20 kA	20 kA
Short-Circuit Current Rating (AC) SCCR	200 kA	150 kA	150 kA	200 kA	150 kA
IEC Electrical					
Nominal AC Voltage (50/60Hz) U_o / U_n	120 V	240 V	277 V	400 V	600 V
Maximum Continuous Operating Voltage (AC) U_c	150 V	300 V	350 V	480 V	750 V
Nominal Discharge Current (8/20 μ s) I_n	20 kA				
Maximum Discharge Current (8/20 μ s) I_{max}	100 kA	100 kA	100 kA	100 kA	60 kA
Impulse Discharge Current (10/350 μ s) I_{imp}	12.5 kA	12.5 kA	12.5 kA	10 kA	5 kA
Specific Energy W/R	39 kJ/ Ω	39 kJ/ Ω	39 kJ/ Ω	25 kJ/ Ω	6.25 kJ/ Ω
Charge Q	6.25 As	6.25 As	6.25 As	5 As	2.5 As
Voltage Protection Level U_p	1000 V	1400 V	1500 V	2000 V	2700 V
Response Time t_a	< 25 ns				
Back-Up Fuse (max)	315 A/250 A gG				250A gG
Short-Circuit Current Rating (AC) I_{SCCR}	25 kA/50 kA				50 kA
TOV Withstand 5s U_T	175 V	337 V	403 V	581 V	871 V
TOV 120 min $U_{T/mode}$	229 V/safe fail	442 V/safe fail	529 V/safe fail	762 V/safe fail	1,143 V/safe fail
Number of Ports	1				
Mechanical					
Operating Temperature Range T_a	-31°F to 185°F (-35°C to 85°C)				
Permissible Operating Humidity RH	5%...95%				
Altitude	6562 ft [2000 m]				
Terminal Screw Torque M_{max}	39.9 lbf-in [4.5 Nm]				
Conductor Cross Section (max)	35 mm ² (Solid)/25 mm ² (Stranded), 2 AWG (Solid)/4 AWG (Stranded)				
Mounting	35 mm DIN Rail, EN 60715				
Degree of Protection	IP 20				
Housing Material	Thermoplastic: Extinguishing Degree UL 94 V-0				
Thermal Protection	Yes				
Operating State/Fault Indication	Green Flag/Not Green Flag				
Remote Contacts (RC)	Yes				
RC Switching Capacity	AC: 250 V/1 A, 125 V/1 A; DC: 48 V/0.5 A, 24 V/0.5 A, 12 V/0.5 A				
RC Conductor Cross Section (max)	1.5 mm ² (Solid)/16 AWG (Solid)				
Single Unit Weight pounds	1.041	1.133	1.239	1.266	1.286
Single Unit Weight grams	472	514	562	574	583

*Other voltages and configurations available upon request

DT1 DIN Rail Surge Protection IEC Class I+II, 4+0 Mode

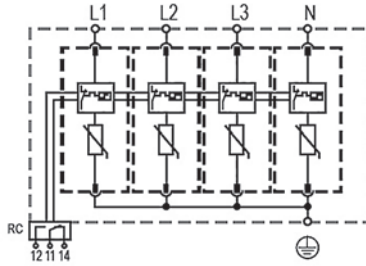

Features

- Compact, yet high surge rated pluggable design, using minimum DIN rail width
- Retaining clip ensures enhanced vibration and shock resistance performance
- Red/Green status indication and change-over contacts standard for remote monitoring

Certification Details:	IEC 61643-11 Class I+II EN 61643-11 Type 1+2 UL 1449, 5th Edition Type 1CA
Complies with:	IEC 61643-11:2011 EN 61643-11:2012 UL 1449, 5th Edition CSA C22.2 No. 269-4
Protection Modes:	L-PE, N-PE, L-L



Part Number	DT115040R	DT130040R	DT135040R	DT148040R
UL Electrical				
UL Nominal Voltage	208/120 V 3Y	415/240 V 3Y	480/277 V 3Y	690/400 V 3Y
Maximum Continuous Operating Voltage (AC) MCOV	150 V/300 V	300 V/600 V	350 V/700 V	480 V/960 V
Voltage Protection Rating VPR	500 V/1,000 V	900 V/1,800 V	1,200 V/2,000 V	1,500V/2,500 V
Nominal Discharge Current (8/20 μ s) I_n	20 kA	20 kA	20 kA	20 kA
Short-Circuit Current Rating (AC) SCCR	200 kA	150 kA	150 kA	200 kA
IEC Electrical				
Nominal AC Voltage (50/60Hz) U_o/U_n	120 V	240 V	277 V	400 V
Maximum Continuous Operating Voltage (AC) U_c	150 V	300 V	350 V	480 V
Nominal Discharge Current (8/20 μ s) I_n	20 kA			
Maximum Discharge Current (8/20 μ s) I_{max}	100 kA	100 kA	100 kA	100 kA
Impulse Discharge Current (10/350 μ s) I_{imp}	12.5 kA	12.5 kA	12.5 kA	10 kA
Specific Energy W/R	39 kJ/ Ω	39 kJ/ Ω	39 kJ/ Ω	25 kJ/ Ω
Charge Q	6.25 As	6.25 As	6.25 As	5 As
Voltage Protection Level U_p	1,000 V	1,400 V	1,500 V	2,000 V
Response Time t_a	< 25 ns			
Back-Up Fuse (max)	315A / 250A gG			
Short-Circuit Current Rating (AC) I_{SCCR}	25 kA / 50 kA			
TOV Withstand 5s UT	175 V	337 V	403 V	581 V
TOV 120 min $U_{T/mode}$	229 V/safe fail	442 V/safe fail	529 V/safe fail	762 V/safe fail
Number of Ports	1			
Mechanical				
Operating Temperature Range T_a	-31°F to 185°F (-35°C to 85°C)			
Permissible Operating Humidity RH	5%...95%			
Altitude	6562 ft [2000 m]			
Terminal Screw Torque M_{max}	39.9 lbf-in [4.5 Nm]			
Conductor Cross Section (max)	35 mm ² (Solid)/25 mm ² (Stranded), 2 AWG (Solid)/4 AWG (Stranded)			
Mounting	35 mm DIN Rail, EN 60715			
Degree of Protection	IP 20			
Housing Material	Thermoplastic: Extinguishing Degree UL 94 V-0			
Thermal Protection	Yes			
Operating State/Fault Indication	Green Flag / Not Green Flag			
Remote Contacts (RC)	Yes			
RC Switching Capacity	AC: 250 V/1 A, 125 V/1 A; DC: 48 V/0.5 A, 24 V/0.5 A, 12 V/0.5 A			
RC Conductor Cross Section (max)	1.5 mm ² (Solid)/16 AWG (Solid)			
Single Unit Weight pounds	1.396	1.519	1.661	1.696
Single Unit Weight grams	633	689	753	769

*Other voltages and configurations available upon request

DT2 DIN Rail Surge Protection IEC Class II, 1+0 Mode

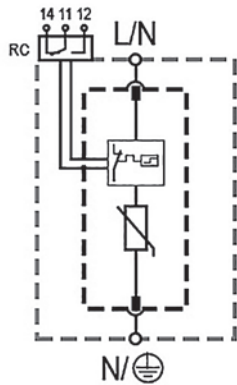

Features

- Compact, yet high surge rated pluggable design, using minimum DIN rail width
- Retaining clip ensures enhanced vibration and shock resistance performance
- Red/Green status indication and change-over contacts standard for remote monitoring

Certification Details: IEC 61643-11 Class I+II
EN 61643-11 Type 1+2
UL 1449, 5th Edition Type 1CA

Complies with: IEC 61643-11:2011
EN 61643-11:2012
UL 1449, 5th Edition
CSA C22.2 No. 269-4

Protection Modes: L-N, N-PE, L-L



Part Number	DT27510R	DT215010R	DT230010R	DT235010R	DT248010R	DT255010R	DT275010R
UL Electrical							
UL Nominal Voltage	60 V	120 V	240 V	277 V	400 V	480 V	600 V
Maximum Continuous Operating Voltage (AC) MCOV	75 V	150 V	300 V	350 V	480 V	550 V	750 V
Voltage Protection Rating VPR	330 V	600 V	900 V	1,000 V	1,500 V	2,000 V	2,500 V
Nominal Discharge Current (8/20 μ s) I_n	20 kA						
Short-Circuit Current Rating (AC) SCCR	100 kA	200 kA	150 kA	200 kA	200 kA	200 kA	200 kA
IEC Electrical							
Nominal AC Voltage (50/60Hz) U_o/U_n	60 V	120 V	240 V	277 V	400 V	480 V	600 V
Maximum Continuous Operating Voltage (AC) U_c	75 V	150 V	300 V	350 V	480 V	550 V	750 V
Nominal Discharge Current (8/20 μ s) I_n	20 kA						
Maximum Discharge Current (8/20 μ s) I_{max}	75 kA	75 kA	65 kA	65 kA	65 kA	50 kA	50 kA
Voltage Protection Level U_p	800 V	1,250 V	1,500 V	1,750 V	2,300 V	2,500 V	3,400 V
Response Time t_A	< 25 ns						
Back-Up Fuse (max)	315 A/250 A gG						
Short-Circuit Current Rating (AC) I_{SCCR}	25 kA/50 kA						
TOV Withstand 5s U_T	114 V	229 V	337 V	403 V	581 V	697 V	871 V
TOV 120 min $U_{T(mode)}$	114 V/ withstand	229 V/ safe fail	442 V/ safe fail	529 V/ safe fail	762 V/ safe fail	915 V/ Safe fail	1143 V/ safe fail
Number of Ports	1						
Mechanical							
Operating Temperature Range T_a	-31°F to 185°F (-35°C to 85°C)						
Permissible Operating Humidity RH	5%...95%						
Altitude	6562 ft [2000 m]						
Terminal Screw Torque M_{max}	39.9 lbf-in [4.5 Nm]						
Conductor Cross Section (max)	35 mm ² (Solid)/25 mm ² (Stranded), 2 AWG (Solid)/4 AWG (Stranded)						
Mounting	35 mm DIN Rail, EN 60715						
Degree of Protection	IP 20						
Housing Material	Thermoplastic: Extinguishing Degree UL 94 V-0						
Thermal Protection	Yes						
Operating State/Fault Indication	Green Flag / Not Green Flag						
Remote Contacts (RC)	Yes						
RC Switching Capacity	AC: 250 V/1 A, 125 V/1 A; DC: 48 V/0.5 A, 24 V/0.5 A, 12 V/0.5 A						
RC Conductor Cross Section (max)	1.5 mm ² (Solid)/16 AWG (Solid)						
Single Unit Weight pounds	0.274	0.283	0.298	0.309	0.320	0.335	0.355
Single Unit Weight grams	124	128	135	140	145	-	161

*Other voltages and configurations available upon request

DT2 DIN Rail Surge Protection IEC Class II, 2+0 Mode

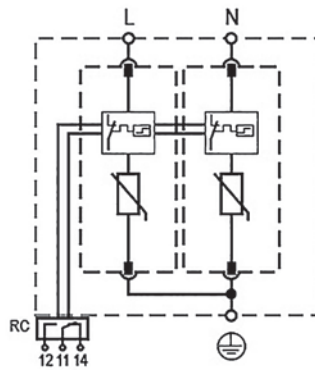

Features

- Compact, yet high surge rated pluggable design, using minimum DIN rail width
- Retaining clip ensures enhanced vibration and shock resistance performance
- Red/Green status indication and change-over contacts standard for remote monitoring

Certification Details: IEC 61643-11 Class II
EN 61643-11 Type 2
UL 1449, 5th Edition Type 1CA

Complies with: IEC 61643-11:2011
EN 61643-11:2012
UL 1449, 5th Edition
CSA C22.2 No. 269-4

Protection Modes: L-PE, N-PE, L-L



Part Number	DT27520R	DT215020R	DT230020R	DT235020R	DT255020R	DT275020R
UL Electrical						
UL Nominal Voltage	60 V	240/120 V 1S 208/120 V 3Y	415/240 V 3Y 240 V 3D	480/277 V 3Y 240 V 3D	480 V 3D	690/400 V 3Y 600 V 3D
Maximum Continuous Operating Voltage (AC) MCOV	75 V/150 V	150 V/300 V	300 V/600 V	350 V/700 V	550 V/1,100 V	750 V/1,500 V
Voltage Protection Rating VPR	330 V/700 V	600 V/1,000 V	900 V/1,800 V	1,000 V/2,000 V	2,000 V/4,000 V	2,500 V/5,000 V
Nominal Discharge Current (8/20 μ s) I_n	20 kA					
Short-Circuit Current Rating (AC) SCCR	100 kA	200 kA	150 kA	200 kA	200 kA	200 kA
IEC Electrical						
Nominal AC Voltage (50/60Hz) U_o/U_n	60 V	120 V	240 V	277 V	480 V	600 V
Maximum Continuous Operating Voltage (AC) U_c	75 V	150 V	300 V	350 V	550 V	750 V
Nominal Discharge Current (8/20 μ s) I_n	20 kA					
Maximum Discharge Current (8/20 μ s) I_{max}	75 kA	75 kA	65 kA	65 kA	50 kA	50 kA
Voltage Protection Level U_p	800 V	1,250 V	1,500 V	1,750 V	2,500 V	3,400 V
Response Time t_A	< 25 ns					
Back-Up Fuse (max)	315A / 250A gG					
Short-Circuit Current Rating (AC) I_{SCCR}	25 kA / 50 kA					
TOV Withstand 5s U_T	114 V	229 V	337 V	403 V	697 V	871 V
TOV 120 min $U_{T(mode)}$	114 V/ withstand	229 V/ withstand	442 V/ safe fail	529 V/ safe fail	915 V Safe fail	1143 V/ safe fail
Number of Ports	1					
Mechanical						
Operating Temperature Range T_a	-31°F to 185°F (-35°C to 85°C)					
Permissible Operating Humidity RH	5%...95%					
Altitude	6562 ft [2000 m]					
Terminal Screw Torque M_{max}	39.9 lbf-in [4.5 Nm]					
Conductor Cross Section (max)	35 mm ² (Solid)/25 mm ² (Stranded), 2 AWG (Solid)/4 AWG (Stranded)					
Mounting	35 mm DIN Rail, EN 60715					
Degree of Protection	IP 20					
Housing Material	Thermoplastic: Extinguishing Degree UL 94 V-0					
Thermal Protection	Yes					
Operating State/Fault Indication	Green Flag/Not Green Flag					
Remote Contacts (RC)	Yes					
RC Switching Capacity	AC: 250 V/1 A, 125 V/1 A; DC: 48 V/0.5 A, 24 V/0.5 A, 12 V/0.5 A					
RC Conductor Cross Section (max)	1.5 mm ² (Solid)/16 AWG (Solid)					
Single Unit Weight pounds	0.538	0.556	0.587	0.609	0.586	0.702
Single Unit Weight grams	244	252	266	276		318

*Other voltages and configurations available upon request

DT2 DIN Rail Surge Protection IEC Class II, 3+0 Mode

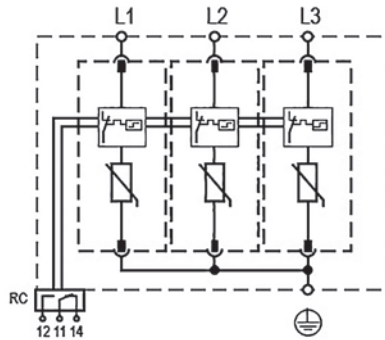

Features

- Compact, yet high surge rated pluggable design, using minimum DIN rail width
- Retaining clip ensures enhanced vibration and shock resistance performance
- Red/Green status indication and change-over contacts standard for remote monitoring

Certification Details: IEC 61643-11 Class II
EN 61643-11 Type 2
UL 1449, 5th Edition Type 1CA

Complies with: IEC 61643-11:2011
EN 61643-11:2012
UL 1449, 5th Edition
CSA C22.2 No. 269-4

Protection Modes: L-PE/N, L-L



Part Number	DT215030R	DT230030R	DT235030R	DT248030R	DT255030R	DT275030R
UL Electrical						
UL Nominal Voltage	208/120 V 3Y 240/120 V 1S	415/240 V 3Y 240 V 3D	480/277 V 3Y	690/400 V 3Y	480 V 3D	600 V 3D
Maximum Continuous Operating Voltage (AC) MCOV	150 V/300 V	300 V/600 V	350 V/700 V	480 V/960 V	550 V/1,100 V	750 V/1,500 V
Voltage Protection Rating VPR	600 V/1,000 V	900 V/1,800 V	1,000 V/2,000 V	1,500 V/3,000 V	2,000/4,000 V	2,500 V/5,000 V
Nominal Discharge Current (8/20 μ s) I_n	20 kA					
Short-Circuit Current Rating (AC) SCCR	200 kA	150 kA	200 kA	200 kA	200 kA	200 kA
IEC Electrical						
Nominal AC Voltage (50/60Hz) U_o / U_n	120 V	240 V	277 V	400 V	480 V	600 V
Maximum Continuous Operating Voltage (AC) U_c	150 V	300 V	350 V	480 V	550 V	750 V
Nominal Discharge Current (8/20 μ s) I_n	20 kA					
Maximum Discharge Current (8/20 μ s) I_{max}	75 kA	65 kA	65 kA	65 kA	65 kA	50 kA
Voltage Protection Level U_p	1250 V	1500V	1750 V	2300 V	2,500 V	3400 V
Response Time t_A	< 25 ns					
Back-Up Fuse (max)	315A / 250A gG					
Short-Circuit Current Rating (AC) I_{SCCR}	25 kA / 50 kA					
TOV Withstand 5s U_T	229 V	337 V	403 V	581 V	697 V	871 V
TOV 120 min $U_{T,mode}$	229 V/ withstand	442 V/ safe fail	529 V/ safe fail	762 V/ safe fail	915 V/ Safe fail	1143 V/ safe fail
Number of Ports	1					
Mechanical						
Operating Temperature Range T_a	-31°F to 185°F (-35°C to 85°C)					
Permissible Operating Humidity RH	5%...95%					
Altitude	6562 ft [2000 m]					
Terminal Screw Torque M_{max}	39.9 lbf-in [4.5 Nm]					
Conductor Cross Section (max)	35 mm ² (Solid) / 25 mm ² (Stranded), 2 AWG (Solid) / 4 AWG (Stranded)					
Mounting	35 mm DIN Rail, EN 60715					
Degree of Protection	IP 20					
Housing Material	Thermoplastic: Extinguishing Degree UL 94 V-0					
Thermal Protection	Yes					
Operating State / Fault Indication	Green Flag / Not Green Flag					
Remote Contacts (RC)	Yes					
RC Switching Capacity	AC: 250 V/1A, 125 V/1A; DC: 48 V/0.5A, 24 V/0.5A, 12 V/0.5A					
RC Conductor Cross Section (max)	1.5 mm ² (Solid) / 16 AWG (Solid)					
Single Unit Weight pounds	0.783	0.829	0.862	0.896	0.900	1.001
Single Unit Weight grams	355	376	391	406		454

*Other voltages and configurations available upon request

DT2 DIN Rail Surge Protection IEC Class II, 4+0 Mode

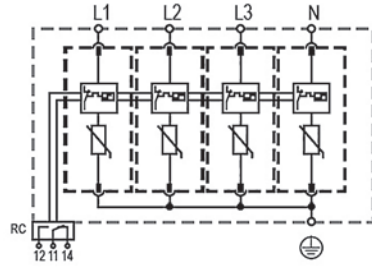

Features

- Compact, yet high surge rated pluggable design, using minimum DIN rail width
- Retaining clip ensures enhanced vibration and shock resistance performance
- Red/Green status indication and change-over contacts standard for remote monitoring

Certification Details:	IEC 61643-11 Class I+II EN 61643-11 Type 1+2 UL 1449, 5th Edition Type 1CA
Complies with:	IEC 61643-11:2011 EN 61643-11:2012 UL 1449, 5th Edition CSA C22.2 No. 269-4
Protection Modes:	L-PE, N-PE, L-L



Part Number	DT215040R	DT230040R	DT235040R	DT248040R	DT255040R
UL Electrical					
UL Nominal Voltage	208/120 V 3Y	415/240 V 3Y	480/277 V 3Y	690/400 V 3Y	690/400 V 3Y
Maximum Continuous Operating Voltage (AC) MCOV	150 V/300 V	300 V/600 V	350 V/700 V	480 V/960 V	550 V/1100 V
Voltage Protection Rating VPR	600 V/1000 V	900 V/1800 V	1000 V/2000 V	1500 V/3000 V	2000 V/4000 V
Nominal Discharge Current (8/20 μ s) I_n	20 kA				
Short-Circuit Current Rating (AC) SCCR	200 kA	150 kA	200 kA	200 kA	200 kA
IEC Electrical					
Nominal AC Voltage (50/60Hz) U_o/U_n	120 V	240 V	277 V	400 V	480 V
Maximum Continuous Operating Voltage (AC) U_c	150 V	300 V	350 V	480 V	550 V
Nominal Discharge Current (8/20 μ s) I_n	20 kA				
Maximum Discharge Current (8/20 μ s) I_{max}	75 kA	65 kA	65 kA	65 kA	65 kA
Voltage Protection Level U_p	1250 V	1500 V	1750 V	2300 V	2500 V
Response Time t_A	< 25 ns				
Back-Up Fuse (max)	315 A/250 A gG				
Short-Circuit Current Rating (AC) I_{SCCR}	25 kA/50 kA				
TOV Withstand 5s U_T	229 V	337 V	403 V	581 V	697 V
TOV 120 min $U_{T/mode}$	229 V/withstand	442 V/safe fail	529 V/safe fail	762 V/safe fail	915 V Safe fail
Number of Ports	1				
Mechanical					
Operating Temperature Range T_a	-31°F to 185°F (-35°C to 85°C)				
Permissible Operating Humidity RH	5%...95%				
Altitude	6562 ft [2000 m]				
Terminal Screw Torque M_{max}	39.9 lbf-in [4.5 Nm]				
Conductor Cross Section (max)	35 mm ² (Solid)/25 mm ² (Stranded), 2 AWG (Solid)/4 AWG (Stranded)				
Mounting	35 mm DIN Rail, EN 60715				
Degree of Protection	IP 20				
Housing Material	Thermoplastic: Extinguishing Degree UL 94 V-0				
Thermal Protection	Yes				
Operating State / Fault Indication	Green Flag/Not Green Flag				
Remote Contacts (RC)	Yes				
RC Switching Capacity	AC: 250 V/1 A, 125 V/1 A; DC: 48 V/0.5 A, 24 V/0.5 A, 12 V/0.5 A				
RC Conductor Cross Section (max)	1.5 mm ² (Solid) / 16 AWG (Solid)				
Single Unit Weight pounds	1.052	1.114	1.158	1.202	1.200
Single Unit Weight grams	477	505	525	545	

*Other voltages and configurations available upon request

DT2 DIN Rail Surge Protection Class II, 1+0 Mode, 100 kA

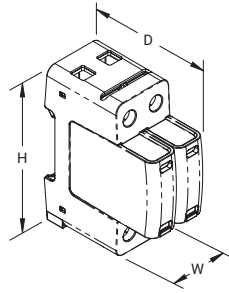

Features

- Compact, yet high surge rated pluggable design, using minimum DIN rail width
- External back-up fuse is not required up to 315 A (IEC only)
- Retaining clip ensures enhanced vibration and shock resistance performance
- Red/Green status indication and change-over contacts standard for remote monitoring

Surges and voltage transients are a major cause of expensive electronic equipment failure and business disruption. Damage may result in the loss of capital outlays, such as computers and communications equipment, as well as consequential loss of revenue and profits due to unscheduled system downtime. nVent ERICO offers multiple series of surge protective devices (SPDs) suitable for a vast range of applications that provide reliable protection from voltage transients on power

distribution systems. The DT2 Series DIN Rail Surge Protective Devices provide reliable and efficient protection against voltage transients within the IEC Class II and UL Type 1CA environments. Tested and independently certified to the IEC and UL standards, the DT2 Series provides a range of safety and performance features for the harshest environments and suitable for protection within a wide range of applications.

Catalog Number	DT2150R100	DT2350R100	DT2550R100	DT2300R100
Nominal System Voltage (U_n)	120 V	277 V	480 V	240 V
Max Continuous Operating Voltage (U_c)	150 V	350 V	550 V	300 V
Nominal Discharge Current (I_n), IEC	40 kA 8/20 μ s			
Max Discharge Current (I_{max}), IEC	100 kA 8/20 μ s			
Voltage Protection Level (U_p)	1,250 V	1,750 V	2,500 V	1,500 V
Frequency	50–60 Hz			
Response Time	25 ns Max			
Back-Up Fuse @ I_{sc}	250 A @ 50 kA 315 A @ 25 kA			
Protection Modes	L-PE N-PE L-N L-PEN	L-PE N-PE L-N L-PEN	L-PE N-PE (TN-S) L-PEN L-N	L-PE N-PE L-N L-PEN
Short Circuit Current Rating (I_{sc})	25 kA 50 kA			
Temporary Over Voltage 120 min (U_t /mode)	229 V Safe Fail	529 V Safe Fail	915 V Safe Fail	442 V Safe Fail
Temporary Over Voltage Withstand 5 s (U_t)	229 V	403 V	697 V	337 V
Technology	Thermal Disconnect			
Torque (TQ)	4.50 N-m			
Connection, Solid	35 mm ² Max			
Connection, Stranded	25 mm ² Max			
Humidity	5–95% RH			
Temperature	–40 to 70°C			
Mounting	35 mm top hat DIN rail	35 mm top hat DIN rail	35 mm DIN Rail, EN 60715	35 mm top hat DIN rail
Enclosure Rating	IP 20			
Enclosure Material	UL® 94 V-0 Thermoplastic			
Remote Contacts	Yes			
Status Indication	Mechanical flag			
Remote Contact Switching Capacity	1.0 A @ 250 VAC 1.0 A @ 125 VAC 0.5 A @ 48 VDC 0.5 A @ 24 VDC 0.5 A @ 12 VDC	1.0 A @ 250 VAC 1.0 A @ 125 VAC 0.5 A @ 48 VDC 0.5 A @ 24 VDC 0.5 A @ 12 VDC	1.0 A @ 250 VAC 1.0 A @ 125 V 0.5 A @ 48 VDC 0.5 A @ 24 V 0.5 A @ 12 V	1.0 A @ 250 VAC 1.0 A @ 125 VAC 0.5 A @ 48 VDC 0.5 A @ 24 VDC 0.5 A @ 12 VDC
Dimensions H x D x W	89.92 mm x 69.09 mm x 36.070 mm			
Unit Weight	0.128 kg	0.140 kg	0.152 kg	0.135 kg Min
Complies With	EN 61643-11 Type 2 IEC® 61643-11 Class II			
Replacement Module	DT2150M	DT2350M	DT2550M	DT2300M

*Other voltages and configurations available upon request

EDT2 Enhanced DIN Rail Surge Protection IEC Class II, 1+0 Mode

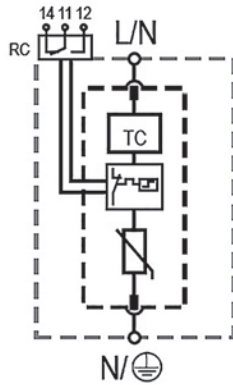

Features

- Compact, yet high surge rated pluggable design, using minimum DIN rail width
- Retaining clip ensures enhanced vibration and shock resistance performance
- Red/Green status indication and change-over contacts standard for remote monitoring

Certification Details:	IEC 61643-11 Class I+II EN 61643-11 Type 1+2 UL 1449, 5th Edition Type 1CA
Complies with:	IEC 61643-11:2011 EN 61643-11:2012 UL 1449, 5th Edition CSA C22.2 No. 269-4
Protection Modes:	L-N, N-PE, L-L



Part Number	EDT27510R	EDT215010R	EDT230010R	EDT235010R	EDT248010R	EDT255010R	EDT275010R
UL Electrical							
UL Nominal Voltage	60 V	120 V	240 V	277 V	400 V	480 V	600 V
Maximum Continuous Operating Voltage (AC) MCOV	75 V	150 V	300 V	350 V	480 V	550 V	750 V
Voltage Protection Rating VPR	600 V	700 V	1,200 V	1,200 V	1,500 V	1,800 V	2,500 V
Nominal Discharge Current (8/20 μ s) I_n	20 kA						
Short-Circuit Current Rating (AC) SCCR	85 kA	200 kA	150 kA	200 kA	200 kA	200 kA	200 kA
IEC Electrical							
Nominal AC Voltage (50/60Hz) U_c/U_n	60 V	120 V	240 V	277 V	400 V	480 V	600 V
Maximum Continuous Operating Voltage (AC) U_c	75 V	150 V	300 V	350 V	480 V	550 V	750 V
Nominal Discharge Current (8/20 μ s) I_n	20 kA						
Maximum Discharge Current (8/20 μ s) I_{max}	75 kA	75 kA	65 kA	65 kA	65 kA	65 kA	50 kA
Voltage Protection Level U_p	800 V	1,250 V	1,650 V	1,750 V	2,300 V	2,500 V	3,500 V
Response Time t_A	< 25 ns						
Back-Up Fuse (max)	315 A/250 A gG						
Short-Circuit Current Rating (AC) I_{SCCR}	25 kA / 50 kA						
TOV Withstand 120 min U_T	150 V	300 V	442 V	529 V	762 V	918 V	1,200 V
Number of Ports	1						
Mechanical							
Operating Temperature Range T_a	-31°F to 185°F (-35°C to 85°C)						
Permissible Operating Humidity RH	5%...95%						
Altitude	6562 ft [2000 m]						
Terminal Screw Torque M_{max}	39.9 lbf-in [4.5 Nm]						
Conductor Cross Section (max)	35 mm ² (Solid)/25 mm ² (Stranded), 2 AWG (Solid)/4 AWG (Stranded)						
Mounting	35 mm DIN Rail, EN 60715						
Degree of Protection	IP 20						
Housing Material	Thermoplastic: Extinguishing Degree UL 94 V-0						
Thermal Protection	Yes						
Operating State/Fault Indication	Green Flag/Not Green Flag						
Remote Contacts (RC)	Yes						
RC Switching Capacity	AC: 250 V/1 A, 125 V/1 A; DC: 48 V/0.5 A, 24 V/0.5 A, 12 V/0.5 A						
RC Conductor Cross Section (max)	1.5 mm ² (Solid)/16 AWG (Solid)						
Single Unit Weight pounds	0.287	0.296	0.307	0.325	0.331	0.342	0.364
Single Unit Weight grams	130	134	139	147	150	155	165

*Other voltages and configurations available upon request

EDT2 Enhanced DIN Rail Surge Protection IEC Class II, 2+0 Mode

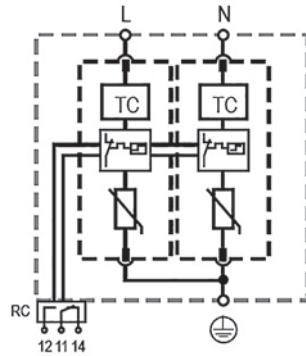

Features

- Includes nVent ERICO TD Technology to ensure reliability throughout adverse voltage conditions
- Enhanced temporary over voltage (TOV) withstand capability
- Compact, yet high surge rated pluggable design, using minimum DIN rail width
- Retaining clip ensures enhanced vibration and shock resistance performance
- Red/Green status indication and change-over contacts standard for remote monitoring

Certification Details: UL® 1449 Edition 5 Type 1CA

Complies with: EN 61643-11 Type 2
IEC® 61643-11 Class II

Protection Modes: L-N, N-PE, L-L



Part Number	EDT215020R	EDT230020R	EDT235020R	EDT248020R	EDT255020R	EDT275020R
UL Electrical						
UL Nominal Voltage	208/120 V 3Y 240/120 V 1S	415/240 V 3Y 240 V 3D	480/277 V 3Y 240 V 3D	690/400 V 3Y	690/400 V 3Y 480 V 3D	600 V 3D
Maximum Continuous Operating Voltage (AC) MCOV	150 V/300 V	300 V/600 V	350 V/700 V	480 V/960 V	550 V/1,100 V	750 V/1,500 V
Voltage Protection Rating VPR	600 V/1,200 V	1,200 V/1,800 V	1,200 V/2,000 V	1,500 V/3,000 V	1,800 V/3,000 V	2,500 V/5,000 V
Nominal Discharge Current (8/20 μs) I _n	20 kA					
Short-Circuit Current Rating (AC) SCCR	200 kA	150 kA	200 kA	200 kA	200 kA	200 kA
IEC Electrical						
Nominal AC Voltage (50/60Hz) U _n /U _n	120 V	240 V	277 V	400 V	400 V	600 V
Maximum Continuous Operating Voltage (AC) U _c	150 V	300 V	350 V	480 V	550 V	750 V
Nominal Discharge Current (8/20 μs) I _n	20 kA					
Maximum Discharge Current (8/20 μs) I _{max}	75 kA	65 kA	65 kA	65 kA	65 kA	50 kA
Voltage Protection Level U _p	1250 V	1650 V	1750 V	2300 V	2500 V	3500 V
Response Time t _a	< 25 ns					
Back-Up Fuse (max)	315 A/250 A gG					
Short-Circuit Current Rating (AC) I _{SCCR}	25 kA/50 kA					
TOV Withstand 120 min U _T	300 V	442 V	529 V	762 V	918 V	1200 V
Number of Ports	1					
Mechanical						
Operating Temperature Range T _a	-31°F to 185°F (-35°C to 85°C)					
Permissible Operating Humidity RH	5%...95%					
Altitude	6562 ft [2000 m]					
Terminal Screw Torque M _{max}	39.9 lbf-in [4.5 Nm]					
Conductor Cross Section (max)	35 mm ² (Solid)/25 mm ² (Stranded), 2 AWG (Solid)/4 AWG (Stranded)					
Mounting	35 mm DIN Rail, EN 60715					
Degree of Protection	IP 20					
Housing Material	Thermoplastic: Extinguishing Degree UL 94 V-0					
Thermal Protection	Yes					
Operating State / Fault Indication	Green Flag/Not Green Flag					
Remote Contacts (RC)	Yes					
RC Switching Capacity	AC: 250 V/1 A, 125 V/1 A; DC: 48V/0.5 A, 24 V/0.5 A, 12 V/0.5 A					
RC Conductor Cross Section (max)	1.5 mm ² (Solid)/16 AWG (Solid)					
Single Unit Weight pounds	0.583	0.605	0.640	0.653	0.675	0.719
Single Unit Weight grams	264	274	290	296	306	326

*Other voltages and configurations available upon request

EDT2 Enhanced DIN Rail Surge Protection IEC Class II, 3+0 Mode

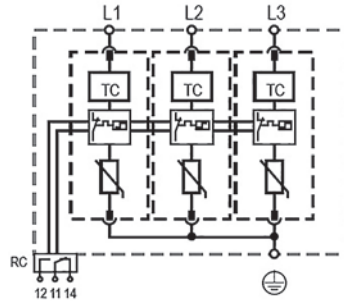

Features

- Compact, yet high surge rated pluggable design, using minimum DIN rail width
- Retaining clip ensures enhanced vibration and shock resistance performance
- Red/Green status indication and change-over contacts standard for remote monitoring

Certification Details:	IEC 61643-11 Class II EN 61643-11 Type 2 UL 1449, 5th Edition Type 1CA
Complies with:	IEC 61643-11:2011 EN 61643-11:2012 UL 1449, 5th Edition CSA C22.2 No. 269-4
Protection Modes:	L-PE/N, L-L



Part Number	EDT215030R	EDT230030R	EDT235030R	EDT248030R	EDT255030R	EDT275030R
UL Electrical						
UL Nominal Voltage	208/120 V 3Y 240/120 V 1S	415/240 V 3Y 240 V 3D	480/277 V 3Y	690/400 V 3Y	480V 3D	600 V 3D
Maximum Continuous Operating Voltage (AC) MCOV	150 V/300 V	300 V/600 V	350 V/700 V	480 V/960 V	550 V/1,100 V	750 V/1,500 V
Voltage Protection Rating VPR	700 V/1,500 V	1,200 V/2,000 V	1,200 V/2,000 V	1,500 V/2,500 V	1,800 V/3,000 V	2,500 V/5,000 V
Nominal Discharge Current (8/20 μ s) I_n	20 kA					
Short-Circuit Current Rating (AC) SCCR	200 kA	150 kA	200 kA	200 kA	200 kA	200 kA
IEC Electrical						
Nominal AC Voltage (50/60Hz) U_n/U_n	120 V	240 V	277 V	400 V	400 V	600 V
Maximum Continuous Operating Voltage (AC) U_c	150 V	300 V	350 V	480 V	550 V	750 V
Nominal Discharge Current (8/20 μ s) I_n	20 kA					
Maximum Discharge Current (8/20 μ s) I_{max}	75 kA	65 kA	65 kA	65 kA	65 kA	50 kA
Voltage Protection Level U_p	1,250 V	16,50 V	1,750 V	2300 V	2,500 V	3,500 V
Response Time t_a	< 25 ns					
Back-Up Fuse (max)	315 A/250 A gG					
Short-Circuit Current Rating (AC) I_{SCCR}	25 kA/50 kA					
TOV Withstand 120 min U_r	300 V	442 V	529 V	762 V	918 V	1,200 V
Number of Ports	1					
Mechanical						
Operating Temperature Range T_a	-31°F to 185°F (-35°C to 85°C)					
Permissible Operating Humidity RH	5%...95%					
Altitude	6562 ft [2000 m]					
Terminal Screw Torque M_{max}	39.9 lbf-in [4.5 Nm]					
Conductor Cross Section (max)	35 mm ² (Solid)/25 mm ² (Stranded), 2 AWG (Solid)/4 AWG (Stranded)					
Mounting	35 mm DIN Rail, EN 60715					
Degree of Protection	IP 20					
Housing Material	Thermoplastic: Extinguishing Degree UL 94 V-0					
Thermal Protection	Yes					
Operating State/Fault Indication	Green Flag/Not Green Flag					
Remote Contacts (RC)	Yes					
RC Switching Capacity	AC: 250 V/1 A, 125 V/1 A; DC: 48 V/0.5 A, 24 V/0.5 A, 12 V/0.5 A					
RC Conductor Cross Section (max)	1.5 mm ² (Solid)/16 AWG (Solid)					
Single Unit Weight pounds	0.823	0.856	0.909	0.929	0.962	1.028
Single Unit Weight grams	373	388	412	421	436	466

*Other voltages and configurations available upon request

EDT2 Enhanced DIN Rail Surge Protection IEC Class II, 4+0 Mode

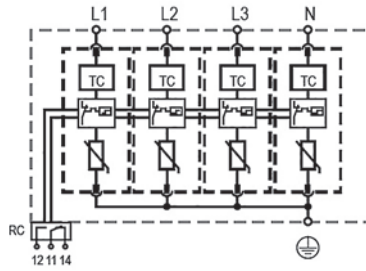

Features

- Compact, yet high surge rated pluggable design, using minimum DIN rail width
- Retaining clip ensures enhanced vibration and shock resistance performance
- Red/Green status indication and change-over contacts standard for remote monitoring

Certification Details: IEC 61643-11 Class II
EN 61643-11 Type 2
UL 1449, 5th Edition Type 1CA

Complies with: IEC 61643-11:2011
EN 61643-11:2012
UL 1449, 5th Edition
CSA C22.2 No. 269-4

Protection Modes: L-PE, N-PE, L-L



Part Number	EDT215040R	EDT230040R	EDT235040R	EDT248040R	EDT255040R
UL Electrical					
UL Nominal Voltage	208/120 V 3Y	415/240 V 3Y	480/277 V 3Y	690/400 V 3Y	690/400V 3Y
Maximum Continuous Operating Voltage (AC) MCOV	150 V/300 V	300 V/600 V	350 V/700 V	480 V/960 V	550 V/1,100 V
Voltage Protection Rating VPR	600 V/1,000 V	1,200 V/2,000 V	1,200 V/2,000 V	1,500 V/2,500 V	1,800 V/3,000 V
Nominal Discharge Current (8/20 μ s) I_n	20 kA				
Short-Circuit Current Rating (AC) SCCR	200 kA	150 kA	200 kA	200 kA	200 kA
IEC Electrical					
Nominal AC Voltage (50/60Hz) U_o/U_n	120 V	240 V	277 V	400 V	400 V
Maximum Continuous Operating Voltage (AC) U_c	150 V	300 V	350 V	480 V	550 V
Nominal Discharge Current (8/20 μ s) I_n	20 kA				
Maximum Discharge Current (8/20 μ s) I_{max}	75 kA	65 kA	65 kA	65 kA	65 kA
Voltage Protection Level U_p	1,250 V	1,650 V	1,750 V	2,300 V	2,500 V
Response Time t_a	< 25 ns				
Back-Up Fuse (max)	315 A/250 A gG				
Short-Circuit Current Rating (AC) I_{SCCR}	25 kA/50 kA				
TOV Withstand 120 min U_T	300 V	442 V	529 V	762 V	918 V
Number of Ports	1				
Mechanical					
Operating Temperature Range T_a	-31°F to 185°F (-35°C to 85°C)				
Permissible Operating Humidity RH	5%...95%				
Altitude	6562 ft [2000 m]				
Terminal Screw Torque M_{max}	39.9 lbf-in [4.5 Nm]				
Conductor Cross Section (max)	35 mm ² (Solid)/25 mm ² (Stranded), 2 AWG (Solid)/4 AWG (Stranded)				
Mounting	35 mm DIN Rail, EN 60715				
Degree of Protection	IP 20				
Housing Material	Thermoplastic: Extinguishing Degree UL 94 V-0				
Thermal Protection	Yes				
Operating State/Fault Indication	Green Flag / Not Green Flag				
Remote Contacts (RC)	Yes				
RC Switching Capacity	AC: 250 V/1 A, 125 V/1 A; DC: 48 V/0.5 A, 24 V/0.5 A, 12 V/0.5 A				
RC Conductor Cross Section (max)	1.5 mm ² (Solid)/16 AWG (Solid)				
Single Unit Weight pounds	1.105	1.149	1.220	1.246	1.290
Single Unit Weight grams	501	521	553	565	585

*Other voltages and configurations available upon request

EDT2 Enhanced DIN Rail Surge Protection Class II, 1+0 Mode, 100 kA

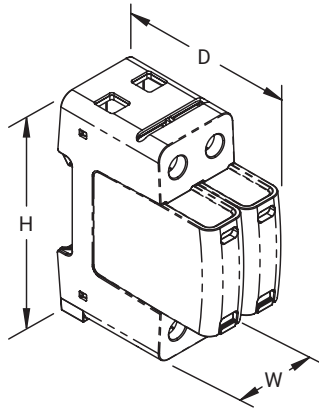

Features

- Includes nVent ERICO TD Technology to ensure reliability throughout adverse voltage conditions
- Enhanced temporary over voltage (TOV) withstand capability
- External back-up fuse is not required up to 315 A (IEC only)
- Compact, yet high surge rated pluggable design, using minimum DIN rail width
- Retaining clip ensures enhanced vibration and shock resistance performance
- Red/Green status indication and change-over contacts standard for remote monitoring

Part Number	EDT2150R100	EDT2300R100	EDT2350R100	EDT2550R100
Nominal System Voltage (U_n)	120 V	240 V	277 V	480 V
Max Continuous Operating Voltage (U_c)	150 V	300 V	350 V	550 V
Nominal Discharge Current (I_n), IEC	40 kA 8/20 μ s			
Max Discharge Current (I_{max}), IEC	100 kA 8/20 μ s			
Voltage Protection Level (U_p)	1,250 V	1,500 V	1,750 V	2,500 V
Back-Up Fuse @ I_{scrr}	250 A @ 50 kA 315 A @ 25 kA			
Frequency	50–60 Hz			
Response Time	25 ns Max			
Protection Modes	L-PE N-PE L-N L-PEN			L-PE N-PE (TN-S) L-PEN L-N
Short Circuit Current Rating (I_{scrr})	25 kA 50 kA			
Temporary Over Voltage 120 min (U_t /mode)	229 V Safe Fail	442 V Safe Fail	529 V Safe Fail	915 V Safe Fail
Temporary Over Voltage Withstand 5 s (U_t)	229 V	337 V	403 V	697 V
Technology	Thermal Disconnect			
Connection, Solid	35 mm ² Max			
Connection, Stranded	25 mm ² Max			
Torque (TQ)	4.5 N-m			
Humidity	5–95% RH			
Temperature	–40 to 70°C			
Enclosure Material	UL® 94 V-0 Thermoplastic			
Enclosure Rating	IP 20			
Mounting	35 mm top hat DIN rail			35 mm DIN Rail, EN 60715
Remote Contact Switching Capacity	1.0 A @ 250 VAC 1.0 A @ 125 VAC 0.5 A @ 48 VDC 0.5 A @ 24 VDC 0.5 A @ 12 VDC			1.0 A @ 250 VAC 1.0 A @ 125 V 0.5 A @ 48 VDC 0.5 A @ 24 V 0.5 A @ 12 V
Remote Contacts	Yes			
Status Indication	Mechanical flag			
Depth (D)	69.09 mm			
Height (H)	89.92 mm			
Width (W)	36.07 mm			
Unit Weight	0.128 kg	0.135 kg	0.140 kg	0.152 kg
Complies With	EN 61643-11 Type 2 IEC® 61643-11 Class II			
Replacement Module	DT2150M	DT2300M	DT2350M	DT2550M

IEC is a registered trademark of the International Electrotechnical Commission.
UL, UR, cUL, cUR, cULus and cURus are registered certification marks of UL LLC.

PVT1 Photovoltaic Surge Protection Class I

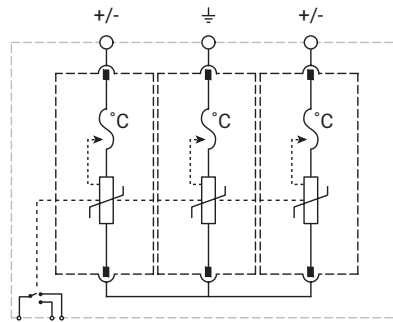

Features

- Uniquely designed for protection of centralized solar inverters on the DC input side and string boxes
- Thermal protection included to ensure safe failure modes
- Compact, yet high surge rated pluggable design, using minimum DIN rail width



Part Number	PVT11000R	PVT11500R
Max Continuous Operating Voltage (U_{cpv})	1,100 V	1,500 VDC
Maximum Discharge Current (8/20 μ s) I_{max}	50 kA	50 kA
Nominal Discharge Current (I_n), IEC	20 kA 8/20 μ s	
Impulse Current (I_{imp})	6.25 kA 10/350 μ s	5.00 kA 10/350 μ s
Total Discharge Current (I_{total})	12.5 kA 10/350 μ s; 50.0 kA 8/20 μ s	10.0 kA 10/350 μ s; 40.0 kA 8/20 μ s
Voltage Protection Level (U_p)	4,000 V	5,000 V
Response Time	25 ns Max	
Short Circuit Current Rating (I_{scct})	11 kA	
Max Continuous Operating Voltage (V_{pvdc})	1,100 VDC	1,500 VDC
Voltage Protection Rating (VPR)	2,500 V	4,000 V
Nominal Discharge Current (I_n), UL	20 kA 8/20 μ s	
Short Circuit Current Rating (SCCR)	50 kA	65 kA
Protection Modes	-ve to PE; -ve to +ve; +ve to PE	
Altitude	2000 m Max	
Humidity	5 – 95 % RH	
Temperature	-40°F to 185°F (-40°C to 85°C)	
Connection, Flexible	25 mm ²	
Connection, Solid	35 mm ²	
Connection, Stranded	35 mm ²	
Enclosure Material	UL [®] 94V-0 Thermoplastic	
Enclosure Rating	IP 20	
Mounting	35 mm top hat DIN rail	
Torque (TQ)	4.5 N m Max	
Remote Contact Switching Capacity	1.0 A @ 125 VAC; 1.0 A @ 250 VAC; 0.5 A @ 12 VDC; 0.5 A @ 24 VDC; 0.5 A @ 48 VDC	
Remote Contacts	Yes	
Status Indication	Mechanical flag	
Depth (D)	8.5 cm	
Height (H)	9.0 cm	
Width (W)	5.4 cm	
Unit Weight	0.46 kg	0.60 kg
Replacement Module	PVT1500M; PVT1500SM	PVT1750M; PVT1750SM
Certification Details	UL [®] 1449 Edition 5 Type 1CA	
Complies With	EN 50539-11 Type 1, Type 2	

PVT2 Photovoltaic Surge Protection Class II

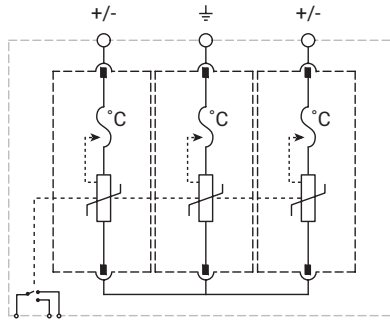

Features

- Suited for use at the DC input of distributed string inverters in solar arrays
- Thermal protection included to ensure safe failure modes
- Compact, yet high surge rated pluggable design, using minimum DIN rail width



Part Number	PVT21000R	PVT21500R
Max Continuous Operating Voltage (U_{cpv})	1,100 V	1,500 VDC
Nominal Discharge Current (I_n), IEC	20 kA 8/20 μ s	
Max Discharge Current (I_{max})	50 kA 8/20 μ s	50 kA 8/20 μ s
Total Discharge Current (I_{total})	50 kA 8/20 μ s	40 kA 8/20 μ s
Voltage Protection Level (U_p)	4,000 V	5,000 V
Response Time	25 ns Max	
Short Circuit Current Rating (I_{scrr})	11 kA	
Max Continuous Operating Voltage (V_{pvc})	1,100 VDC	1,500 VDC
Voltage Protection Rating (VPR)	3,000 V	4,000 V
Nominal Discharge Current (I_n), UL	20 kA 8/20 μ s	
Short Circuit Current Rating (SCCR)	50 kA	65 kA
Protection Modes	-ve to PE; -ve to +ve; +ve to PE	
Altitude	2000 m Max	
Humidity	5-95% RH	
Temperature	-40°F to 185°F (-40°C to 85°C)	
Connection, Flexible	25 mm ²	
Connection, Solid	35 mm ²	
Connection, Stranded	35 mm ²	
Enclosure Material	UL® 94V-0 Thermoplastic	
Enclosure Rating	IP 20	
Mounting	35 mm top hat DIN rail	
Torque (TQ)	4.5 N m Max	
Remote Contact Switching Capacity	1.0 A @ 125 VAC; 1.0 A @ 250 VAC; 0.5 A @ 12 VDC; 0.5 A @ 24 VDC; 0.5 A @ 48 VDC	
Remote Contacts	Yes	
Status Indication	Mechanical flag	
Depth (D)	6.9 cm	
Height (H)	9.0 cm	
Width (W)	5.4 cm	
Unit Weight	0.41 kg	0.45 kg
Replacement Module	PVT2500M	PVT2750M
Certification Details	UL® 1449 Edition 5 Type 1CA	
Complies With	EN 50539-11 Type 2	

Spark Gap Diverter, Type 1

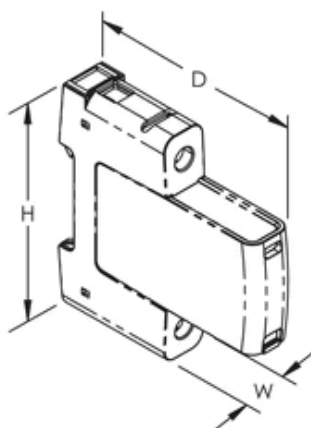

Features

- Effective equipotential bonding provides N-PE equalization protection bond on TT power distribution systems



Catalog Number	SGT110010	SGT15010
Nominal Discharge Current (I_n), UL	–	20 kA 8/20 μ s
Nominal Discharge Current (I_n), IEC	100 kA 8/20 μ s	50 kA 8/20 μ s
Short Circuit Current Rating (I_{scsr})	50 kA	
Max Continuous Operating Voltage (U_c)	305 VAC	
Max Discharge Current (I_{max}), Per Mode	150 kA 8/20 μ s	100 kA 8/20 μ s
Impulse Current (I_{imp})	100 kA 10/350 μ s	50 kA 10/350 μ s
Voltage Protection Level (U_p)	1,500 V	
Response Time	100 ns max	
Follow Current Interrupt Rating (I_f)	100 A	
Temporary Over Voltage Withstand 200 ms (U_t), N-PE	1,200 V	
Voltage Protection Rating (VPR)	–	1,200 V
Frequency	50–60 Hz	
Technology	Thermal Disconnect	
Protection Modes	N-PE	
Distribution System	TT (N-PE)	
Connection, Solid	35 mm ² max	
Connection, Stranded	25 mm ² max	
Torque (TQ)	4.5 N·m max	
Humidity	0–95	5–95
Altitude	2,000 m max	4,000 m max
Temperature	–40 to 70°C	–40 to 85°C
Mounting	35 mm DIN Rail, EN 60715	
Enclosure Rating	IP 20	
Enclosure Material	UL® 94V-0 Thermoplastic	
Remote Contacts	No	
Status Indication	Mechanical flag	
Depth (D)	69 mm	
Width (W)	18 mm	
Height (H)	90 mm	
Unit Weight	0.18 kg	
Complies With	IEC® 61643-11 Class I, Class II EN 61643-11 Type 1, Type 2	
Certification Details	–	UL® 1449 Edition 4 Type 1CA
Replacement Module	SGT1100M	SGT150M

Spark Gap Diverter, Type 2

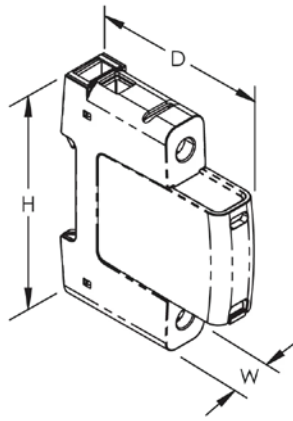

Features

- Effective equipotential bonding provides N-PE equalization protection bond on TT power distribution systems



Catalog Number	SGT24010R
Nominal Discharge Current (I_n), UL	20 kA 8/20 μ s
Nominal Discharge Current (I_n), IEC	40 kA 8/20 μ s
Short Circuit Current Rating (I_{scrr})	50 kA
Max Continuous Operating Voltage (U_c)	305 VAC
Max Discharge Current (I_{max}), Per Mode	65 kA 8/20 μ s
Voltage Protection Level (U_p)	1,500 V
Response Time	100 s max
Follow Current Interrupt Rating (I_f)	100 kA
Temporary Over Voltage Withstand 200 ms (U_t), N-PE	1,200 V
Voltage Protection Rating (VPR)	1,200 V
Frequency	50–60 Hz
Technology	Thermal Disconnect
Protection Modes	N-PE
Distribution System	TT (N-PE)
Connection, Solid	35 mm ² max
Connection, Stranded	25 mm ² max
Torque (TQ)	4.5 N·m max
Humidity	5–95
Altitude	4,000 m max
Temperature	–40 to 85 °C
Mounting	35 mm DIN Rail, EN 60715
Enclosure Rating	IP 20
Enclosure Material	UL® 94V-0 Thermoplastic
Remote Contacts	Yes
Status Indication	Mechanical flag
Remote Contact Switching Capacity	1 A @ 250 VAC A 0.5 A @ 48 VDC A 0.5 A @ 24 VDC A 0.5 A @ 12 VDC A
Depth (D)	85 mm
Width (W)	18 mm
Height (H)	90 mm
Unit Weight	0.12 kg
Complies With	EN 61643-11 Type 2 IEC® 61643-11 Class II
Certification Details	UL® 1449 Edition 4 Type 1CA
Replacement Module	SGT240M

Transient Discriminating Surge Diverter, 20 kA Three Mode

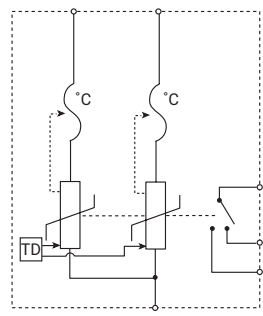
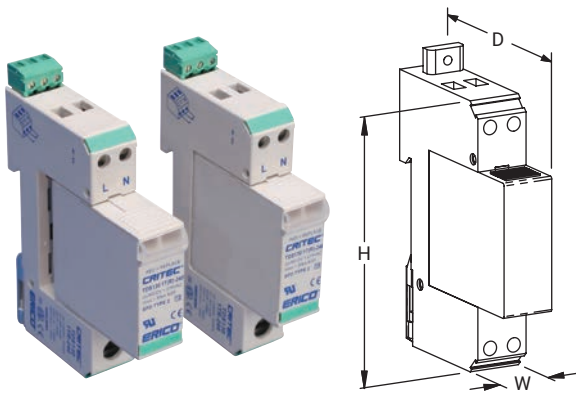

Features

- 20 kA $\frac{8}{20}$ μ s surge rating provides robust surge protection
- TD Technology with thermal disconnect protection
- Compact package, modular DIN rail mounting for limited space requirements
- Three modes of protection: L-N, L-PE and N-PE
- Indication flags and voltage-free contacts provide remote status monitoring
- Separate plug and base design facilitates replacement of a failed surge module



Part Number	TDS1301T150	TDS1301T240	TDS1301TR150	TDS1301TR240
Nominal System Voltage (U _n)	120–150 VAC	220–240 VAC	120–150 VAC	220–240 VAC
Max Continuous Operating Voltage (U _c)	170 VAC	275 VAC	170 VAC	275 VAC
Stand-off Voltage	230 VAC	440 VAC	230 VAC	440 VAC
Voltage Protection Rating (VPR)	800 V @ 3 kA L-N 500 V @ 3 kA L+N-PE	1,500 V @ 3 kA L-N 800 V @ 3 kA L+N-PE	800 V @ 3 kA L-N 500 V @ 3 kA L+N-PE	1,500 V @ 3 kA L-N 800 V @ 3 kA L+N-PE
Nominal Discharge Current (I _n), Per Mode	8 kA 8/20 μ s			
Max Discharge Current (I _{max})	20 kA 8/20 μ s L-N, 20 kA 8/20 μ s L-PE			
Back-Up Overcurrent Protection	63 A			
Short Circuit Current Rating (SCCR)	200 kA			
Frequency	0–100 Hz			
Protection Modes	L-N L-PE N-PE			
Response Time	5 ns Max			
Technology	TD technology with thermal disconnect			
Connection, PE Solid	35 mm ² Max			
Connection, PE Stranded	25 mm ² Max			
Connection, Solid	6 mm ² Max			
Connection, Stranded	6 mm ² Max			
Mounting	35 mm top hat DIN rail			
Enclosure Material	UL [®] 94V-0 Thermoplastic			
Enclosure Rating	IP 20 NEMA [®] -1			
Remote Contacts	No		Yes	
Status Indication	Mechanical flag			
Temperature	–40 to 80°C			
Module Width	1 M			
Depth (D)	6.8 cm			
Height (H)	9.0 cm			
Width (W)	1.8 cm			
Unit Weight	0.12 kg			
Certification Details	UL [®] 1449 Edition 5, Type 4CA			
Complies With	ANSI [®] /IEEE [®] C62.41.2-2002 Cat A, Cat B IEC [®] 61643-1 Class III			
Replacement Module	TDS130M150	TDS130M240	TDS130M150	TDS130M240

Surge Diverter, 24/48 DC

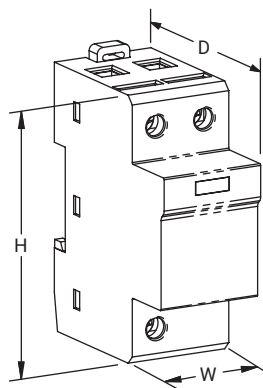

Features

- 40 kA 8/20 μ s surge rating per mode, 80 kA per line, 120 kA total per pair
- Suitable for exposed DC wiring
- Indication flag provides clear visual indication of life status
- Suitable for both 24 VDC and 48 VDC distribution systems

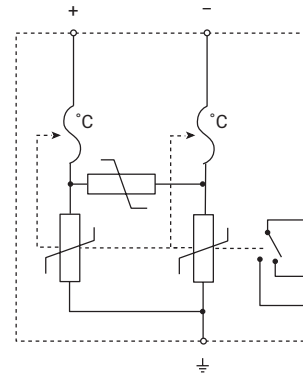

Part Number	DSD1402BR2448
Nominal System Voltage (U_n)	0–48 VDC
Max Continuous Operating Voltage (U_c)	60 VAC; 60 VDC
Max Discharge Current (I_{max}), Per Mode	40 kA 8/20 μ s
Nominal Discharge Current (I_n)	20 kA 8/20 μ s
Voltage Protection Level (U_p), + to – @ I_n	600 V
Voltage Protection Level (U_p), L-N	280 V @ 3 kA
Frequency	0–60 Hz
Protection Modes	Common Differential
Short Circuit Current Rating (SCCR)	25 kA
Technology	MOV with thermal disconnect
Connection, Solid	35 mm ² Max
Connection, Stranded	25 mm ² Max
Mounting	35 mm top hat DIN rail
Enclosure Material	UL® 94 V-0 Thermoplastic
Enclosure Rating	IP 20 NEMA®-1
Status Indication	Mechanical flag
Terminal Torque	42 N m Max
Remote Contacts	Yes
Temperature	–40 to 80°C
Module Width	2 m
Depth (D)	6.8 cm
Part Number	DSD1402BR2448
Height (H)	9.0 cm
Width (W)	3.6 cm
Unit Weight	0.20 kg
Complies With	ANSI®/IEEE® C62.41.2-2002 Cat A, Cat B, Cat C; ANSI®/IEEE® C62.41.2-2002 Scenario II, Exposure 2, 20 kA 8/20 μ s, 2 kA 10/350 μ s IEC® 61643-1 Class II
Certifications	CE, DSD140; Qualifoudre
Standard Packaging Quantity	1 pc
UPC	78285652474
EAN-13	8711893029802

DT2C Compact Surge Protection Class II, 1+1 Mode

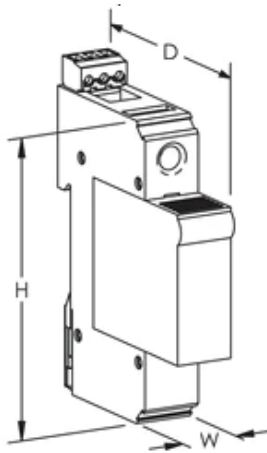

Features

- Two-mode protection in slim, one module housing

Catalog Number	DT2C32011R
Nominal System Voltage (U_n)	230 V
Nominal Discharge Current (I_n), IEC, L-N	15 kA 8/20 μ s
Nominal Discharge Current (I_n), IEC, N-PE	20 kA 8/20 μ s
Max Continuous Operating Voltage (U_c)	320 VAC L-N 255 VAC N-PE
Max Discharge Current (I_{max}), IEC, L-N	35 kA 8/20 μ s
Max Discharge Current (I_{max}), IEC, N-PE	35 kA 8/20 μ s
Follow Current Interrupt Rating (I_i)	0.1 kA
Voltage Protection Level (U_p)	1,500 V
Response Time, L-N	25 s max
Response Time, N-PE	100 s max
Back-Up Fuse @ I_{scrr}	63 A @ 25 kA A
Short Circuit Current Rating (I_{scrr})	25 kA
Protection Modes	L-N N-PE
Distribution System	TT TN-S
Temporary Over Voltage Withstand 5 s (U_t), L-N	335 V
Temporary Over Voltage Withstand 200 ms (U_t), N-PE	1,200 V
Technology	Thermal Disconnect
Connection, Solid	6 mm ² max
Connection, PE Solid	35 mm ² max
Connection, Stranded	4 mm ² max
Connection, PE Stranded	25 mm ² max
Humidity	5–95
Temperature	–40 to 85°C
Mounting	35 mm top hat DIN rail
Enclosure Rating	IP 20
Enclosure Material	UL® 94 V-0 Thermoplastic
Remote Contacts	Yes
Status Indication	Mechanical flag
Remote Contact Switching Capacity	0.5 A @ 250 VAC A 3 A @ 125 VAC A
Depth (D)	68 mm
Width (W)	18 mm
Height (H)	90 mm
Unit Weight	0.13 kg
Complies With	IEC® 61643-11 Class II EN 61643-11 Type 2

DT2C Compact Surge Protection Class II, 2+0 Mode

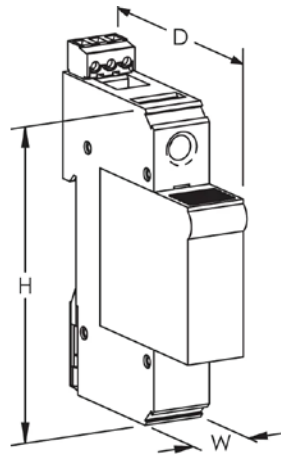

Features

- Two-mode protection in slim, one module housing

Catalog Number	DT2C32020R
Nominal System Voltage (U_n)	230 V
Nominal Discharge Current (I_n), IEC	15 kA 8/20 μ s
Max Continuous Operating Voltage (U_c)	320 VAC
Max Discharge Current (I_{max}), IEC	40 kA 8/20 μ s
Follow Current Interrupt Rating (I_f)	100 kA
Voltage Protection Level (U_p)	1,500 V
Response Time	25 s max
Back-Up Fuse @ I_{sc}	63 A @ 25 kA A
Short Circuit Current Rating (I_{sc})	25 kA
Protection Modes	L-PE N-PE
Distribution System	TN-S
Temporary Over Voltage Withstand 5 s (U_t), L-N	335 V
Technology	Thermal Disconnect
Connection, Solid	6 mm ² max
Connection, PE Solid	35 mm ² max
Connection, Stranded	4 mm ² max
Connection, PE Stranded	25 mm ² max
Humidity	5–95
Temperature	–40 to 85°C
Mounting	35 mm top hat DIN rail
Enclosure Rating	IP 20
Enclosure Material	UL® 94 V-0 Thermoplastic
Remote Contacts	Yes
Status Indication	Mechanical flag
Remote Contact Switching Capacity	0.5 A @ 250 VAC A 3 A @ 125 V A
Depth (D)	68 mm
Width (W)	18 mm
Height (H)	90 mm
Unit Weight	0.15 kg
Complies With	IEC® 61643-11 Class II EN 61643-11 Type 2

Transient Surge Filter

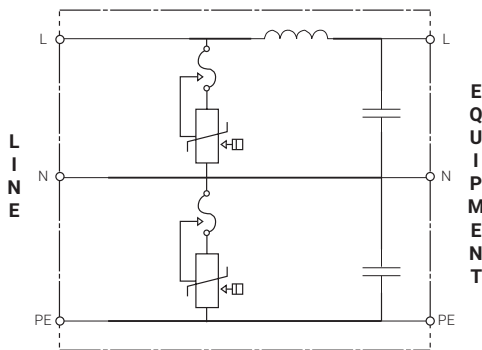
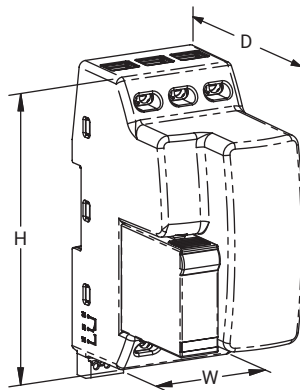

Features

- Compact, space saving design
- Replaceable surge module reduces down time and unprotected time during maintenance
- Compliance to the latest UL 1449 Edition 5 and IEC 61643-11 surge standards and UL 1283 Electromagnetic Interference Filters (EMI) standard
- Low let-through voltages on the critical line to neutral mode
- Transient Discriminating (TD) Technology provides increased service life
- All modes protected at 20 kA 8/20 μ s
- Form C Relay Contacts for Remote Monitoring
- Two Terminals per line



Part Number	TSF6A24V	TSF6A120V	TSF20A120V	TSF6A240V	TSF20A240V
Nominal System Voltage (U_n)	24 V	120 V		240 V	
Rated Load Current (I_L)	6 A		20 A	6 A	20 A
Max Continuous Operating Voltage (U_c)	30 VAC/38 VDC	170 V		275 V	
Stand-off Voltage	–	230		440	
Filtering	–65 dB @ 100 kHz		–50 dB @ 100 kHz	–65 dB @ 100 kHz	–50 dB @ 100 kHz
Frequency	0–100 Hz				
Max Discharge Current (I_{max})	40 kA 8/20 μ s, per phase				
Voltage Protection Rating (VPR) L-N	–	330 V	400 V	–	–
Measured Limiting Voltage (MLV) L-N	–	–	–	620 V	680 V
Nominal Discharge Current (I_n)	3 kA 8/20 μ s, all modes				
Distribution System	1Ph 2W+G				
Connection, Solid	2.5 mm ² - 6.0 mm ² ; #14 - #10				
Connection, Stranded	2.5 mm ² - 6.0 mm ² ; #14 - #10				
Mounting	35 mm top hat DIN rail				
Status Indication	Mechanical flag				
Enclosure Material	UL® 94V-0 Thermoplastic				
Enclosure Rating	IP 20				
Temperature	–35 to 40°C				
Module Width	3 M				
Depth (D) x Height (H) x Width (W)	95 mm x 123 mm x 54 mm				
Unit Weight	508 grams				
Replacement Module	TSF24MDS	TSF120MTDS		TSF240MTDS	
Certifications	CE	CE, cURus, UL 1449 Ed 5, UL 1283 Ed 7			

Surge Reduction Filter N-Series, Single Phase

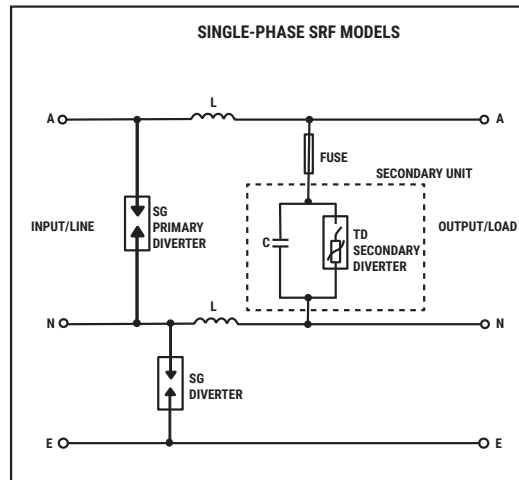
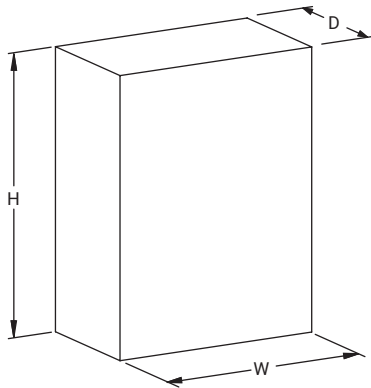

Features

- High-performance protection incorporating Spark Gap and Transient Discriminating (TD) technologies
- High surge rating ideal for exposed critical service entrance applications
- Reduces let-through voltages and rate-of-voltage rise (dv/dt) and helps provide optimum protection for electronic equipment
- Extreme reliability and simplified design with direct connection from input to output
- Comprehensive front panel status and internal diagnostic LEDs



Part Number	SRF163N	SRF1125N
Nominal System Voltage (U _n)	220–240 VAC	
Distribution System	1Ph 2W+G	
System Compatibility	TN-C, TN-C-S, TN-S, TT	
Frequency	50–60 Hz	
Short Circuit Current Rating (SCCR)	43 kA	
Heat Dissipation	25 W	
Filtering	–40 dB @ 100 kHz	
Protection Modes	All modes protected	
Technology	Spark Gap, In-line series low pass sine wave filter, TD technology with thermal disconnect (50 kA 8/20 μs secondary stage)	
Enclosure Material	Metal	
Enclosure Rating	IP 65	
Mounting	Wall mount	
Status Indication	Front panel LED, Internal diagnostic primary and secondary protection LEDs, Change-over contact (Form C dry), 250 VAC/30 VDC/5 A, 4 kV isolation	
Rated Load Current (I _L)	63 A	125 A
Rate of Voltage Rise (dv/dt)	3 V/μs Max	8 V/μs Max
Voltage Protection Level (L-N)	150 V @ 3 kA 8/20 μs 200 V @ 20 kA 8/20 μs	250 V @ 3 kA 8/20 μs 350 V @ 20 kA 8/20 μs
Input Connection	10–35 mm ²	25–120 mm ²
Output Connection	25–120 mm ²	
Depth (D)	200 mm	
Height (H)	300 mm	
Width (W)	400 mm	
Unit Weight	10.3 kg	12.3 kg
Complies With	IEC® 61643-11 Class I, Class II ANSI®/IEEE® C62.41.2-2002 Cat A, Cat B, Cat C ANSI®/IEEE® C62.41.2-2002 Scenario II, Exposure 3, 100 kA 8/20 μs, 10 kA 10/350 μs	

Surge Reduction Filter N-Series, Three Phase

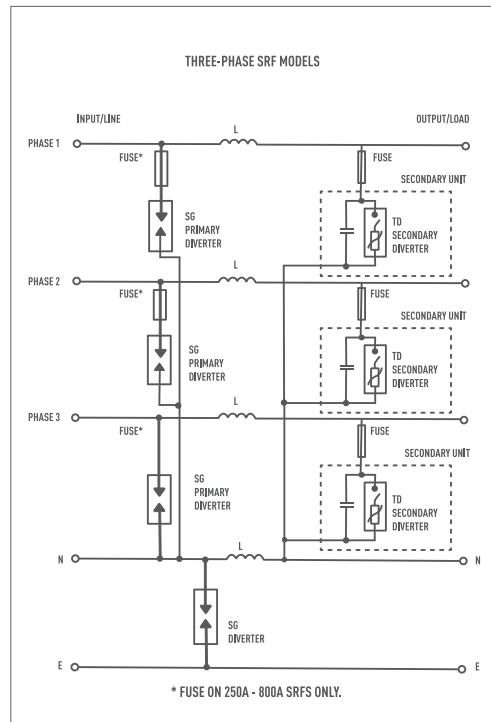
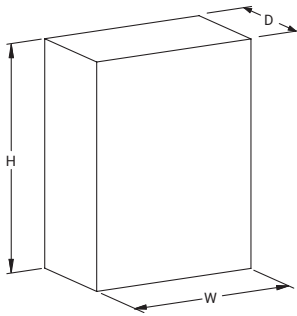

Features

- High-performance protection incorporating Spark Gap and Transient Discriminating (TD) technologies
- High surge rating ideal for exposed critical service entrance applications
- Reduces let-through voltages and rate-of-voltage rise (dv/dt) and helps provide optimum protection for electronic equipment
- Extreme reliability and simplified design with direct connection from input to output
- Comprehensive front panel status and internal diagnostic LEDs



Part Number	SRF363N	SRF3125N	SRF3250N	SRF3500N	SRF3800N
Nominal System Voltage (Un)	220/380–240/415 VAC				
Distribution System	3Ph Y 4W+G				
System Compatibility	TN-C, TN-C-S, TN-S, TT				
Frequency:	50–60 Hz				
Short Circuit Current Rating (SCCR)	43 kA				
Filtering	–40 dB @ 100 kHz				
Protection Modes	All modes protected				
Technology	Spark Gap, In-line series low pass sine wave filter, TD technology with thermal disconnect (50 kA 8/20us secondary stage)				
Enclosure Material	Metal				
Mounting	Wall mount				
Status Indication	Front panel LED, Internal diagnostic primary and secondary protection LEDs, Change-over contact (Form C dry), 250 VAC/30 VDC/5 A, 4 kV isolation				
Rated Load Current (I _L)	63 A	125 A	250 A	500 A	800 A
Heat Dissipation	34 W	56 W	98 W	215 W	260 W
Rate of Voltage Rise (dV/dt)	5 V/μs Max	10 V/μs Max	11 V/μs Max	10 V/μs Max	
Voltage Protection Level (L-N)	200 V @ 3 kA 8/20 μs 250 V @ 20 kA 8/20 μs	300 V @ 3 kA 8/20 μs 380 V @ 20 kA 8/20 μs	300 V @ 3 kA 8/20 μs 500 V @ 20 kA 8/20 μs	320 V @ 3 kA 8/20 μs 550 V @ 20 kA 8/20 μs	320 V @ 3 kA 8/20 μs 550 V @ 20 kA 8/20 μs
Input Connection	10–35 mm ²	25–120 mm ²		10 mm Stud	(2) 10 mm studs
Output Connection	10–35 mm ²	25–120 mm ²		10 mm Stud	(2) 10 mm studs
Enclosure Rating	IP 65			IP 32	
Depth (D)	200 mm			300 mm	
Height (H)	500 mm		800 mm	1,000 mm	1,200 mm
Width (W)	400 mm		600 mm	800 mm	
Unit Weight	17.7 kg	21.6 kg	41.7 kg	76.6 kg	97.2 kg
Complies With	IEC® 61643-11 Class I, Class II ANSI®/IEEE® C62.41.2-2002 Cat A, Cat B, Cat C ANSI®/IEEE® C62.41.2-2002 Scenario II, Exposure 3, 100 kA 8/20 μs, 10 kA 10/350 μs				

High Speed Data Line Protector

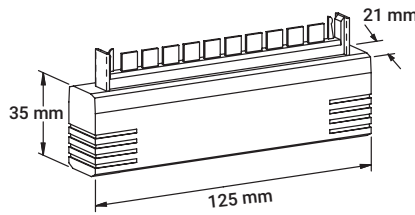

Features

- Multi-stage protection with primary or combination primary/secondary protectors
- 10 pair protector
- Provides both L-L and L-PE protection modes for comprehensive protection Simple installation into Krone® LSA disconnect block
- Data Line Terminator (DLT) available where screw terminal connections are required

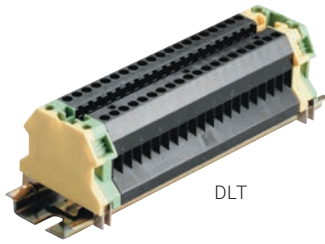

DLT

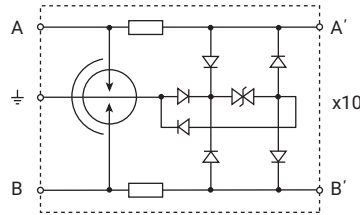

Part Number	HSP10K12	HSP10K36	HSP10K72	HSP10K230
Max Continuous Operating Voltage (U_c)	13 VDC	40 VDC	65 VDC	190 VDC
Max Discharge Current (I_{max}), L+L-PE	20 kA 8/20 μ s			
Rated Load Current (I_L)	150 mA			
Frequency	12 MHz Max			
Transmission Rate	8 Mb/s			
Protection Modes	L-L, L-PE			
Technology	Multi-stage			
Connection Type	Krone® LSA-PLUS			
Impedance Balance	55 dB Max			
Insertion Loss	.4 dB Max			
Return Loss	20 dB Max			
Certifications	UL 497B			

Subscriber Line Protector, Single Stage

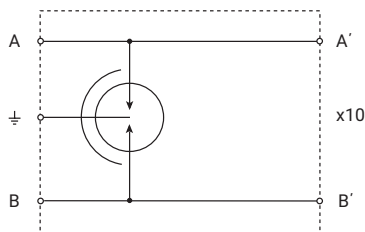
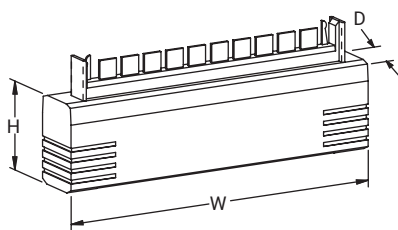
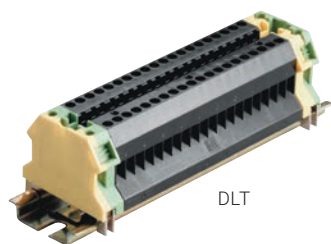

Features

- Single stage protection with primary or combination primary/secondary protectors
- 10 pair protector
- Simple installation into Krone® LSA disconnect block
- Data Line Terminator (DLT) available where screw terminal connections are required



Part Number	SLP10K1F
Max Continuous Operating Voltage (U_0)	190 VDC
Max Discharge Current (I_{max}), L+L-PE	20 kA 8/20 μ s
Rated Load Current (I_L)	1,000 mA
Frequency	12 Hz Max
Transmission Rate	8 Mb/s
Protection Modes	L-L
Technology	Single-stage
Connection Type	Krone® LSA-PLUS
Impedance Balance	48 dB Max
Insertion Loss	.75 dB Max
Return Loss	22 dB Max
Loop Resistance	0.2 Ω
Temperature	-20 to 60°C
Enclosure Material	UL® 94 V-0 Thermoplastic
Depth (D)	21 mm
Height (H)	34.5 mm
Width (W)	125 mm
Unit Weight	22.7 g
Certification Details	UL 497B
Certifications	RCM, CE, cULus
Standard Packaging Quantity	1 pc
UPC	78285647508
EAN-13	9321098000460

Telephone Line Protector

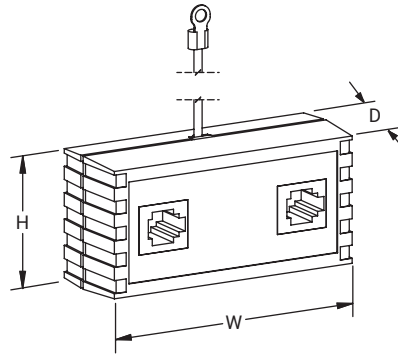

Features

- RJ11 sockets provide simple plug-in connection for 4 or 6 position RJ plugs
- Includes patch cord and adhesive mounting strips
- Provides both L-L and L-PE protection modes for comprehensive protection
- Automatic over-current protection

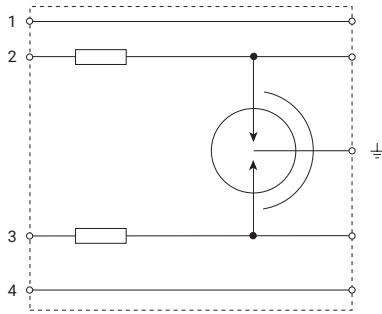

SLP1RJ11

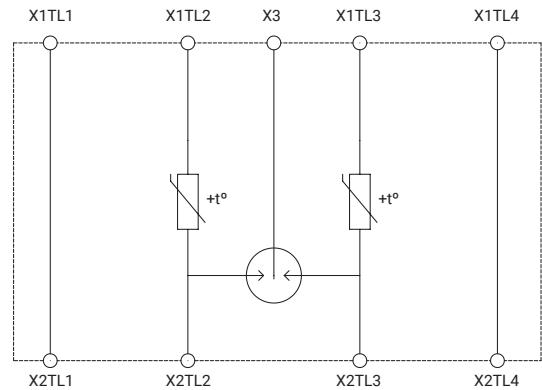
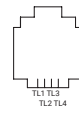

SLP1RJ11A



Part Number	SLP1RJ11	SLP1RJ11A
Max Continuous Operating Voltage (U_c)	280 V	
Max Discharge Current (I_{max}), Per Mode	500 A 8/20 μ s	20 kA 8/20 μ s
Voltage Protection Level (U_p), T-R	110 V	
Voltage Protection Level (U_p), T/R-G	500 V @ 125 A	
Rated Load Current (I_l)	160 mA	120 mA
Connection Type	RJ11	
Ground Lead Length	15.2 cm	
Lead Size	0.75 mm ²	
Temperature	-40°C to 65°C	
Depth (D)	2.8 cm	
Height (H)	3.8 cm	
Width (W)	7.8 cm	7.7 cm
Unit Weight	0.05 kg	
Enclosure Material	UL [®] 94 V-0 Thermoplastic	
Certifications	UL 497 A	RCM, NOM

Coaxial Surge Protector

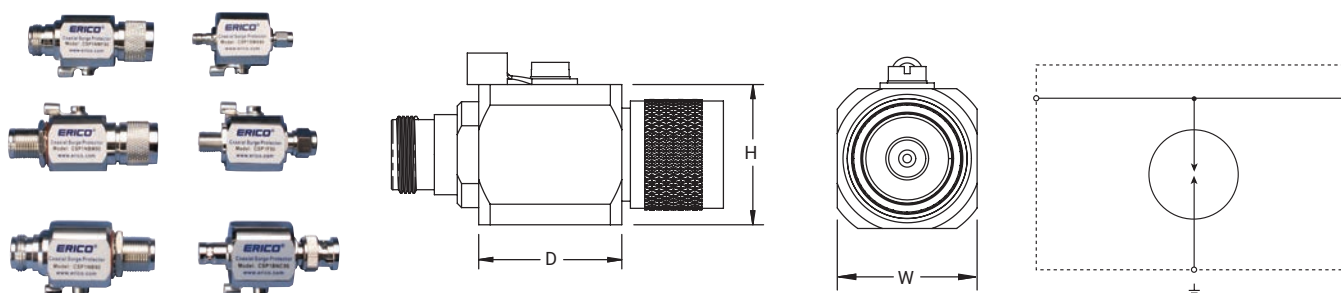

SPECIFICATIONS

Max Discharge Current (I_{max}), Per Mode: 20 kA 8/20 μ s
 Rated Nominal Discharge Current (I_n): 20 kA 8/20 μ s
 Frequency: 0–3 GHz
 Capacitance: 1.5 pF
 Insulation Resistance: 10 G Ω
 Impulse Life: 400 @ 500 A 10/1,000 μ s
 Enclosure Material: Metal
 Enclosure Rating: IP 20; NEMA[®]-1
 Temperature: –40 to 90°C
 Certification: UL 497E

Features

- Simple plug-in installation
- Supplied with mounting bracket and flying lead ground
- Low insertion and return loss
- Wide operating frequency spectrum
- Low spark over voltage, better clamping
- Field-serviceable with replaceable GDT arrestor

Note: To select the appropriate protection voltage, use the following procedure:

1. Determine the transmitter power in Watts (P)
2. Determine the VSWR. If unsure, use 1.5
3. $V_{peak} = VSWR \times 1.4 \times \sqrt{(50P)}$
4. If $V_{peak} < 72$ V, use CSP XXX 90. If $V_{peak} > 72$ V and < 480 V, use CSP XXX 600
5. Taking this value of VSWR and allowing a little margin, this means that typically the 90 V protector is used for Receivers and Transmitters up to 20 W, while the 600 W protector can be used for transmitters up to 900 W.



Part Number	Connection Type	Spark-Over Voltage @ 100 V/ μ s	Spark-Over Voltage @ 100 V/s	Depth D	Height H	Width W	Unit Weight
CSP1NB90	N-Type, Female/Female	450 V	72–108 V	25.4 mm	25 mm	25 mm	133.4 g
CSP1NMF90	N-Type, Male/Female	450 V	72–108 V	25.4 mm	25 mm	25 mm	133.4 g
CSP1BNC90	BNC, Male/Female	450 V	72–108 V	25.4 mm	25 mm	25 mm	133.4 g
CSP1BNC600	BNC, Male/Female	1,100 V	480–720 V	25.4 mm	25 mm	25 mm	133.4 g
CSP1SMA90	SMA, Male/Female	450 V	72–108 V	25.4 mm	25 mm	25 mm	133.4 g
CSP1NB600	N-Type, Female/Female	1,100 V	480–720 V	25.4 mm	25 mm	25 mm	133.4 g
CSP1F90	F-Type, Male/Female	450 V	72–108 V	25.4 mm	25 mm	25 mm	133.4 g
CSP1F600	F-Type, Male/Female	1,100 V	480–720 V	25.4 mm	25 mm	25 mm	133.4 g
CSP1NBM90	N-Bulkhead, Male/Female	450 V	72–108 V	25.4 mm	25 mm	25 mm	133.4 g
CSP1NBM600	N-Bulkhead, Male/Female	1,100 V	480–720 V	25.4 mm	25 mm	25 mm	133.4 g
CSP1NMF600	N-Type, Male/Female	1,100 V	480–720 V	25.4 mm	25 mm	25 mm	133.4 g
CSP1SMA600	SMA, Male/Female	1,100 V	480–720 V	25.4 mm	25 mm	25 mm	133.4 g

Closed Circuit Television Protector

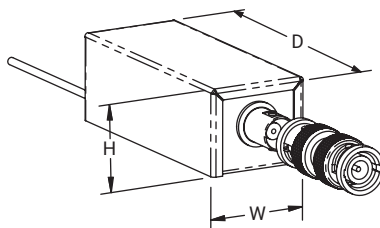

Features

- Robust high energy protection
- Compact package for limited space requirements
- Isolated ground prevents introduction of unwanted noise

Part Number	CCTV12
Nominal System Voltage (U_n)	+/-12 VDC
Max Continuous Operating Voltage (U_c)	+/-14 VDC
Voltage Protection Level (U_p)	60 V @ 5 kA
Nominal Discharge Current (I_n)	10 kA 8/20 μ s
Frequency	100 MHz Max
Transmission Rate	16 Mb/s
Impedance	50-75 Ω
Connection Type	BNC, Female
Mounting	In-line insertion
Temperature	-25 to 70°C
Enclosure Material	Metal
Enclosure Rating	IP 20 NEMA®-1
Depth (D)	27.9 mm
Height (H)	90 mm
Width (W)	22.1 mm
Unit Weight	60 g
Standard Packaging Quantity	1 pc
UPC	78285647021
EAN-13	8711893014204

Ethernet and Power Over Ethernet Surge Protection

THE NATURE OF SURGES ON ETHERNET AND POE

The services considered here are transported on twisted pair. Each service has two wires, or lines, sometimes called the 'a' and 'b' wires.

In the communication industry Ethernet ports are particularly vulnerable to surge damage for a number of reasons:

1. The design of ethernet or PoE ports inside terminal equipment varies
2. Many Ports are designed for indoor applications with low surge exposure but the equipment may end up connecting to wires that enter from outside the building with higher surge exposure.
3. The port design itself has isolation build into it in almost all cases. If the surge exceed these isolation voltages, damage to the port and the equipment can arise.
4. Coordination between protection and isolation is a poorly understood subject and proper consideration to this coordination may not have been given in the design.
5. The need for higher surge and isolation ratings on ethernet and PoE ports to which external wires connect has been subject to review relatively recently hence older design equipment may not have adequate ratings
6. While lot of attention is given in facility protection to lightning protection, grounding and power surge protection, ethernet and PoE connections to external wire can often been overlooked in the overall system design. In many cases this forgotten source of surge entry can cause damage and downtime significantly larger than the equipment cost.

A Good Design

A well designed Ethernet or PoE surge protector need to have high enough ratings to mitigate the common modes surges and have subsequent mechanism to mitigate differential mode surges. In the circuit below of nVent ERICO LANRJ45C6P:

- Gas Discharge Tubes or GDT with a Max Discharge Current (I_{max}), L-GND 10 kA 8/20 μ s and Impulse Current (I_{imp}) 1 kA 10/350 μ s is used to provide common mode protection. This can be used in IEC61643 Class 1 and Class 2 applications.
- Silicon diodes are carefully added to the circuit to provide differential mode or L-L protections. These do not have to have large rating and in this case are Nominal Discharge Current (I_n), L-L of 150 A 8/20 μ s.

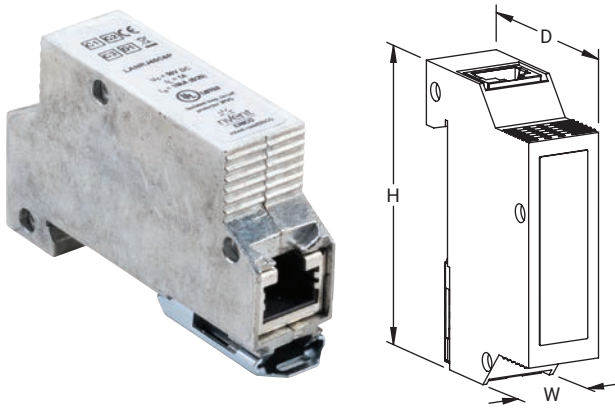

Features

- Rugged, metallic enclosure provides both environmental and electrical shielding
- Up to CAT6 and POE (Power Over Ethernet) protection in one product
- Simple, bi-directional installation

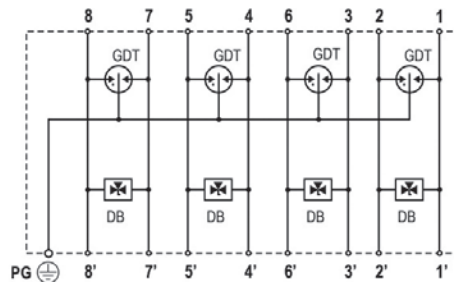

Example Application

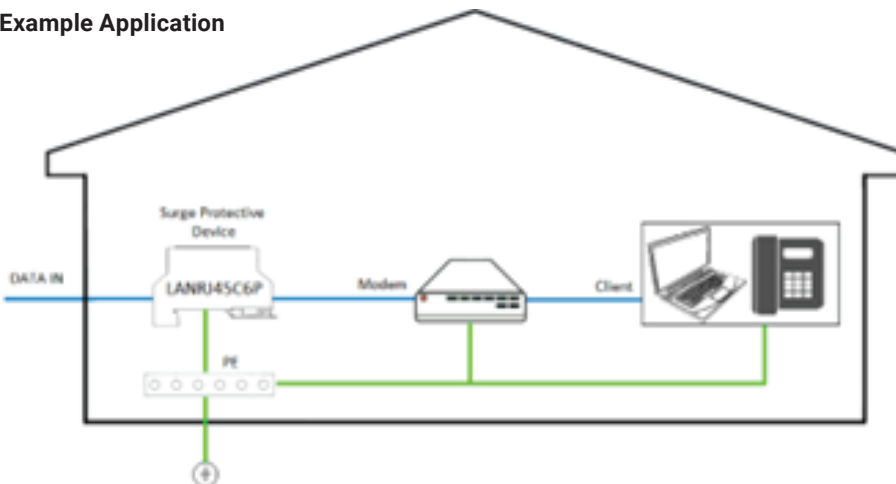

The nVent ERICO LANRJ45C6P has been designed to provide protection to Local Area Networks (LAN) from overvoltage surges and electrostatic discharges created by switching transients in buildings. The product is designed to fulfill all versions of POE applications compatible with IEEE 802.af and IEEE 802.3at.

LAN Surge Protector

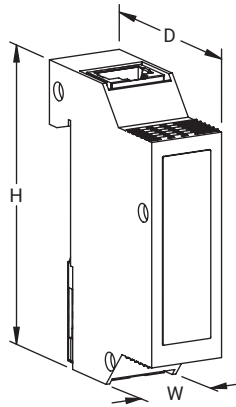
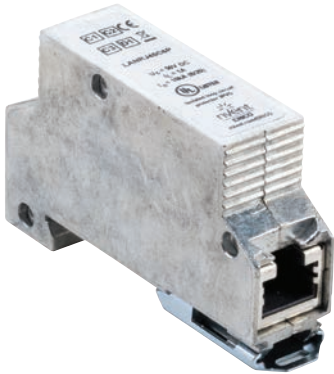

Features

- Rugged, metallic enclosure provides both environmental and electrical shielding
- Up to CAT6 and POE (Power Over Ethernet) protection in one product
- Simple, bi-directional installation

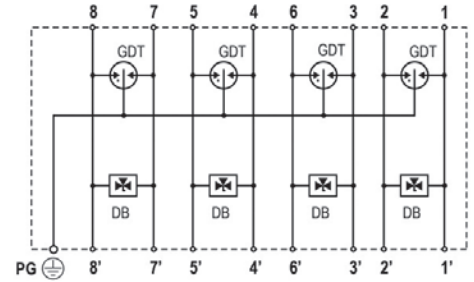

Part Number	LANRJ45C6P
Nominal System Voltage (U_n)	48 VDC
Max Continuous Operating Voltage (U_o)	50 VDC
Voltage Protection Rating (VPR), L-L	150 V
Voltage Protection Rating (VPR), L-PE	550 V
Nominal Discharge Current (I_n), L-L	150 A 8/20 μ s
Max Discharge Current (I_{max}), L-PE	10 kA 8/20 μ s
Impulse Current (I_{imp})	1 kA 10/350 μ s
Rated Load Current (I_L)	1 A
Frequency	250 MHz Max
Baud Rates	10, 100, 1000, 10000 Mbps
Temperature	-40 to 80°C
Connection Type	RJ45
Enclosure Material	Metal
Enclosure Rating	IP 20
Depth (D)	45.5 mm
Height (H)	75 mm
Width (W)	19 mm
Complies With	IEC® 61643-21 UL 497B
Standard Packaging Quantity	1 pc
UPC	78285693008
EAN-13	0782856930082

Data Equipment Protector

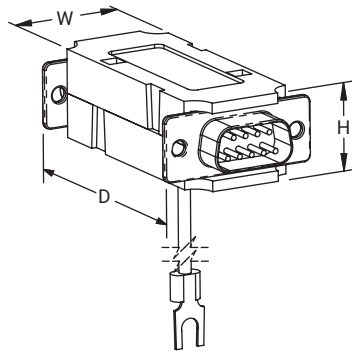

Features

- Models to cover RS-232, RS-423, RS-422 and RS-485 protocols
- Designed to provide both line to signal-ground and signal-ground to protective-earth protection
- Plug-in protection is simple to install

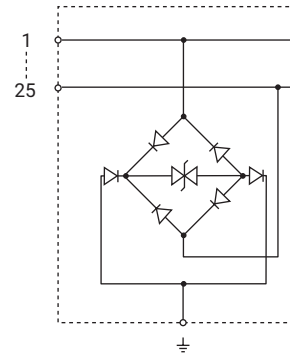

Part Number	DEPRS2322525D	DEPRS23299D	DEPRS42299D
Nominal Discharge Current (I_n)	300 A 8/20 μ s		400 A 8/20 μ s
Max Continuous Operating Voltage (U_c)	15 VDC		6 VDC
Capacitance	30 pF Max		
Protection Modes	All pins to ground		
Connection Type	DB25, Male/Female	DB9, Male/Female	
Depth (D)	6.1 cm		
Height (H)	1.7 cm		
Width (W)	5.4 cm	3.0 cm	
Unit Weight	0.08 kg	0.05 kg	

Universal Transient Barrier, Single Pair

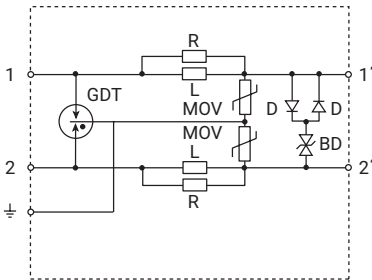
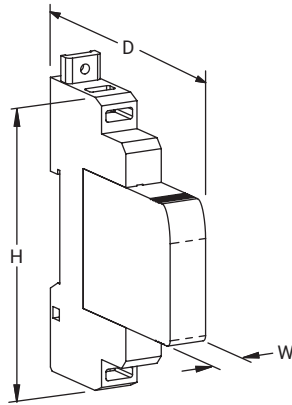

Features

- Compact design universal transient barrier provides protection of low-voltage circuits and transducers
- Separate plug and base design allows hot swappable module replacement
- Multi-stage protection and fine over-voltage protection helps ensure lowest residual surge voltages reach sensitive equipment
- Common-mode and differential-mode protection protects against both possible surge conditions
- Surge rating to 20 kA 8/20 μ s is ideal for exposed wiring
- Allows for protection of 25 analog signals or 50 digital signals per linear foot (0,3 m) of DIN rail space



Part Number	UTB5SP	UTB15SP	UTB30SP	UTB60SP	UTB110SP
Nominal System Voltage (U_n)	0–3 VAC 0–5 VDC	3–10 VAC 5–15 VDC	10–21 VAC 15–30 VDC	21–42 VAC 30–60 VDC	100–120 VAC 60–154 VDC
Max Continuous Operating Voltage (U_c)	5 VAC 7 VDC	12 VAC 18 VDC	23 VAC 33 VDC	45 VAC 64 VDC	150 VAC 170 VDC
Frequency	0.5 MHz	1.0 MHz	2.0 MHz	3.0 MHz	3.0 MHz
Rated Load Current (I_L)	2 A				
Loop Resistance	1 Ω				
Max Discharge Current (I_{max}), L+L-PE	20 kA 8/20 μ s				
Protection Modes	Common, Differential				
Technology	Gas Discharge Tube (GDT), Metal Oxide Varistor (MOV), Silicon Avalanche Diode (SAD)				
Connection, Stranded	1.0 mm ² –4.0 mm ² ; #18–#12				
Mounting	35 mm top hat DIN rail				
Temperature	–20 to 65°C				
Enclosure Material	UL® 94 V-0 Thermoplastic				
Enclosure Rating	IP 20, NEMA®-1				
Depth (D)	72 mm				
Height (H)	90 mm				
Width (W)	12 mm				
Unit Weight	68 g				
Certification Details	UL® 497B				
Complies With	ANSI®/IEEE® C62.41.2-2002 Cat A, Cat B, Cat C				
Voltage Protection Level (U_p), L-L	10 V @ 3 kA	25 V @ 3 kA	44 V @ 3 kA	85 V @ 3 kA	220 V @ 3 kA
Replacement Module	UTB5SPM	UTB15SPM	UTB30SPM	UTB60SPM	UTB110SPM
Certifications	CE NOM UR	CE UR	CE NOM UR	CE UR	CE NOM UR

Universal Transient Barrier, Dual Pair

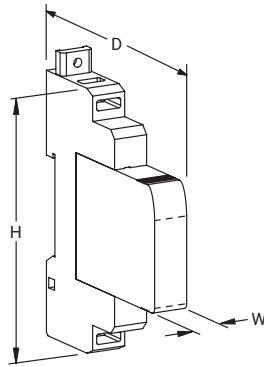

Features

- Compact design universal transient barrier provides protection of low-voltage circuits and transducers
- Separate plug and base design allows hot swappable module replacement
- Multi-stage protection and fine over-voltage protection helps ensure lowest residual surge voltages reach sensitive equipment
- Common-mode and differential-mode protection protects against both possible surge conditions
- Surge rating to 20 kA 8/20 μ s is ideal for exposed wiring
- Allows for protection of 25 analog signals or 50 digital signals per linear foot (0,3 m) of DIN rail space

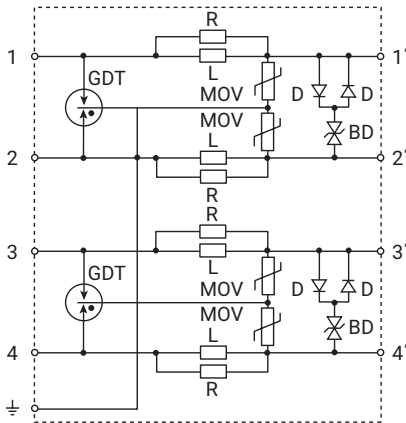

Part Number	UTB5DP	UTB15DP	UTB30DP	UTB60DP	UTB110DP
Nominal System Voltage (U_n)	0–3 VAC 0–5 VDC	3–10 VAC 5–15 VDC	10–21 VAC 15–30 VDC	21–42 VAC 30–60 VDC	100–120 VAC 60–154 VDC
Max Continuous Operating Voltage (U_c)	5 VAC 7 VDC	12 VAC 18 VDC	23 VAC 33 VDC	45 VAC 64 VDC	150 VAC 170 VDC
Rated Load Current (I_L)	800 mA				
Frequency	0.5 MHz	1.0 MHz	2.0 MHz	3.0 MHz	
Loop Resistance	0.6 Ω				
Max Discharge Current (I_{max}), L+L-PE	20 kA 8/20 μ s				
Protection Modes	Common Differential				
Technology	Gas Discharge Tube (GDT); Metal Oxide Varistor (MOV); Silicon Avalanche Diode (SAD)				
Voltage Protection Level (U_p), L-L	10 V @ 3 kA	25 V @ 3 kA	44 V @ 3 kA	85 V @ 3 kA	220 V @ 3 kA
Connection, Stranded	0.75 mm ² –4 mm ²				
Mounting	35 mm top hat DIN rail				
Temperature	–20 to 65°C				
Enclosure Material	UL® 94 V-0 Thermoplastic				
Enclosure Rating	IP 20 NEMA®-1				
Depth (D)	8.5 cm				
Height (H)	9.0 cm				
Width (W)	1.2 cm				
Unit Weight	0.09 kg				
Certification Details	UL® 497B				
Complies With	ANSI®/IEEE® C62.41.2-2002 Cat A, Cat B, Cat C				
Replacement Module	UTB5DPM	UTB15DPM	UTB30DPM	UTB60DPM	UTB110DPM
Certifications	CE, NOM, UR	CE, UR	CE, NOM, UR	CE, UR	CE, NOM, UR

Universal Transient Barrier, Dual Pair Single Power

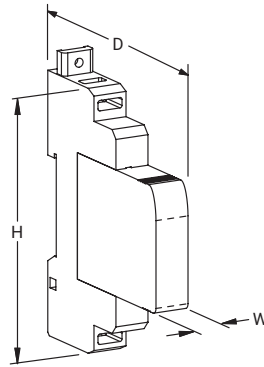

Features

- Compact design universal transient barrier provides protection of low-voltage circuits and transducers
- Separate plug and base design allows hot swappable module replacement
- Multi-stage protection and fine over-voltage protection helps ensure lowest residual surge voltages reach sensitive equipment
- Common-mode and differential-mode protection protects against both possible surge conditions
- Designed for compact protection of signal and power supply in one compact housing

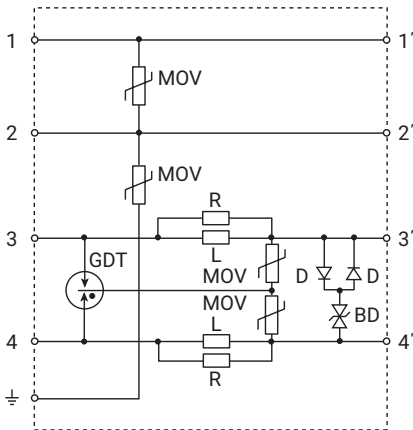

Part Number	UTB30DPS
Nominal System Voltage (U_n)	24–48 VAC; 12–60 VDC
Max Continuous Operating Voltage (U_o)	48 VAC; 60 VDC
Rated Load Current (I_l)	5 A
Frequency	0–60 Hz
Loop Resistance	0 Ω
Max Discharge Current (I_{max}), Per Mode	15 kA 8/20 μ s
Protection Modes	Common; Differential
Technology	Gas Discharge Tube (GDT) Metal Oxide Varistor (MOV) Silicon Avalanche Diode (SAD)
Voltage Protection Level (U_p), L-L	220 V @ 3 kA
Connection, Stranded	0.75 mm ² –4 mm ²
Mounting	35 mm top hat DIN rail
Temperature	–20 to 65°C
Enclosure Material	UL [®] 94 V-0 Thermoplastic
Enclosure Rating	IP 20; NEMA [®] -1
Depth (D)	8.5 cm
Height (H)	9.0 cm
Width (W)	1.2 cm
Unit Weight	0.09 kg
Certification Details	UL [®] 497B
Complies With	ANSI [®] /IEEE [®] C62.41.2-2002 Cat A, Cat B, Cat C
Replacement Module	UTB30DPSM

The electrical specifications shown are specific to the power supply (PS) circuit of the product.

Universal Transient Barrier, Single Pair Isolated Ground

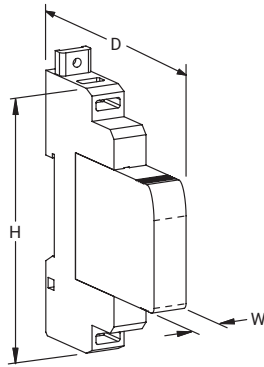

Features

- Compact design universal transient barrier provides protection of low-voltage circuits and transducers
- Separate plug and base design allows hot swappable module replacement
- Multi-stage protection and fine over-voltage protection helps ensure lowest residual surge voltages reach sensitive equipment
- Common-mode and differential-mode protection protects against both possible surge conditions
- Surge rating to 20 kA 8/20 μ s is ideal for exposed wiring
- Allows for protection of 25 analog signals or 50 digital signals per linear foot (0,3 m) of DIN rail space

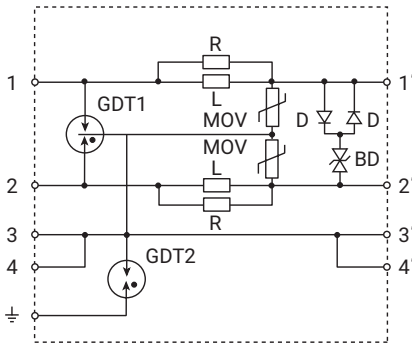

Part Number	UTB5SPG	UTB15SPG	UTB30SPG	UTB60SPG	UTB110SPG
Nominal System Voltage (U_n)	0–3 VAC 0–5 VDC	3–10 VAC 5–15 VDC	10–21 VAC 15–30 VDC	21–42 VAC 30–60 VDC	100–120 VAC 60–154 VDC
Max Continuous Operating Voltage (U_o)	5 VAC 7 VDC	12 VAC 18 VDC	23 VAC 33 VDC	45 VAC 64 VDC	150 VAC 170 VDC
Rated Load Current (I_L)	2 A				
Frequency	0.5 MHz	1.0 MHz	2.0 MHz	3.0 MHz	
Loop Resistance	1 Ω				
Max Discharge Current (I_{max}), L+L-PE	20 kA 8/20 μ s				
Protection Modes	Common Differential				
Technology	Gas Discharge Tube (GDT) Metal Oxide Varistor (MOV) Silicon Avalanche Diode (SAD)				
Voltage Protection Level (U_p), L-L	10 V @ 3 kA	25 V @ 3 kA	44 V @ 3 kA	85 V @ 3 kA	220 V @ 3 kA
Connection, Stranded	0.75 mm ² –4 mm ²				
Mounting	35 mm top hat DIN rail				
Temperature	–20 to 65°C				
Enclosure Material	UL® 94 V-0 Thermoplastic				
Enclosure Rating	IP 20 NEMA®-1				
Depth (D)	7.2 cm				
Height (H)	9.0 cm				
Width (W)	1.2 cm				
Unit Weight	0.07 kg				
Certification Details	UL® 497B				
Complies With	ANSI®/IEEE® C62.41.2-2002 Cat A, Cat B, Cat C				
Replacement Module	UTB5SPGM	UTB15SPGM	UTB30SPGM	UTB60SPGM	UTB110SPGM

Universal Transient Barrier, Modem/Telephone

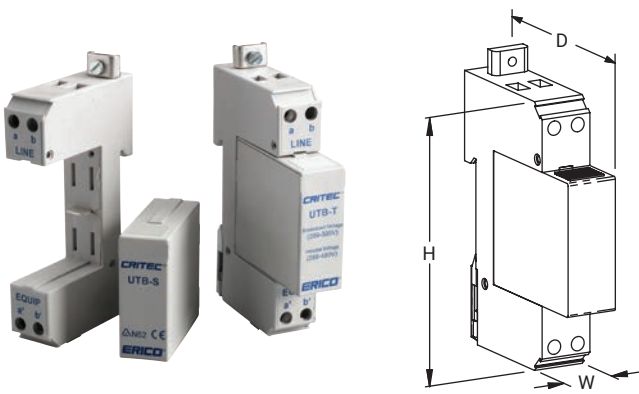

Features

- General purpose barrier provides protection of low-voltage circuits and transducers
- Separate plug and base design allows hot swappable module replacement
- Multi-stage protection and fine over-voltage protection helps ensure lowest residual surge voltages reach sensitive equipment

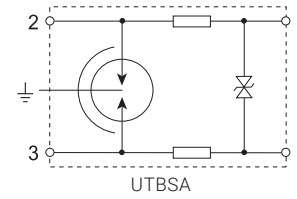
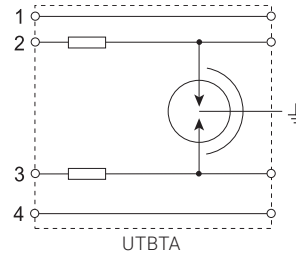

Part Number	UTBSA	UTBTA
Max Continuous Operating Voltage (U_c)	5 VAC 7 VDC	280 V
Frequency	15 MHz	
Voltage Protection Level (U_p), L-L	340 V @ 3 kA	480 V @ 3 kA
Rated Load Current (I_L)	160 mA	
Loop Resistance	1 Ω	
Max Discharge Current (I_{max})	20 kA 8/20 μ s L+L-PE	0.5 kA 8/20 μ s Per Mode
Protection Modes	Common, Differential	
Technology	Gas Discharge Tube (GDT), PTC	
Connection, Stranded	0.75 mm ² –4 mm ²	0.75 mm ² –4 mm ²
Mounting	35 mm top hat DIN rail	
Temperature	-20 to 65°C	
Enclosure Material	UL® 94V-0 Thermoplastic	
Enclosure Rating	IP 20, NEMA®-1	
Depth (D)	6.8 cm	
Height (H)	9.0 cm	
Width (W)	1.8 cm	
Unit Weight	0.10 kg	
Certification Details	UL® 497B	UL® 497A
Complies With	ANSI®/IEEE® C62.41.2-2002 Cat A, Cat B, Cat C	
Replacement Module	UTBSM	UTBTM
Certifications	CE; NOM	CE

RTBN Rail Transient Barrier

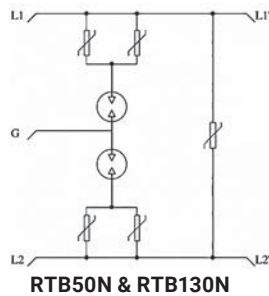
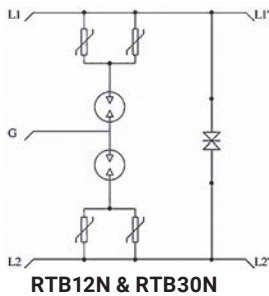
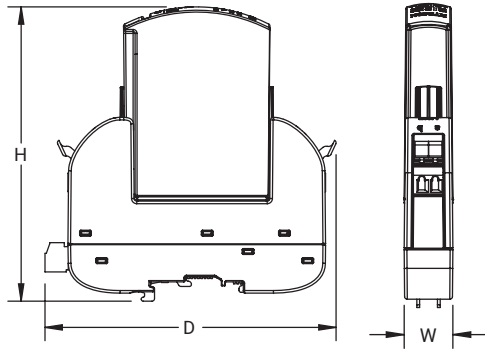

Features

- Surge module easily snaps into place
- Mechanical flag will protrude to indicate the module needs to be replaced
- Thermal disconnect releases the indicator when the device reaches end-of-life, disconnecting itself from the circuit to prevent it from becoming a short or shunt
- Surge module attaches to the base with a latching mechanism that easily locks the device into place, preventing the module from disconnecting during service
- Integration of GDT (gas discharge tube) technology and MOV (metal oxide varistors), a combination that delivers consistency and the capability to protect against fast spikes
- Screw-less cage clamp terminal allows for easy connection, solid or stranded wires are simply pushed in to lock into place, reducing installation time by as much as 75%
- DIN rail grounding connection eliminates the need for extra grounding wires

Part Number	RTB12N	RTB30N	RTB50N	RTB130N
Nominal System Voltage (U_n)	12 VDC; 9 VAC	30 VDC; 21 VAC	50 VDC; 35 VAC	130 VDC; 110 VAC
Max Continuous Operating Voltage (U_c)	18 VDC; 12 VAC	33 VDC; 23 VAC	65 VDC; 50 VAC	170 VDC; 130 VAC
Max Discharge Current (I_{max})	40 kA 8/20 μ s			
Rated Load Current (I_L)	15 A			
Voltage Protection Rating (VPR)	65 V @ 3 kA L-L 245 V @ 3 kA L+L-PE	105 V @ 3 kA L-L 245 V @ 3 kA L+L-PE	230 V @ 3 kA L-L 245 V @ 3 kA L+L-PE	530 V @ 3 kA L-L 495 V @ 3 kA L+L-PE
Loop Resistance	900 $\mu\Omega$			
Mounting	35 mm top hat DIN rail; G type DIN rail			
Protection Modes	L-L; L+L-PE			
Status Indication	Mechanical flag; Remote Contacts			
Connection, Solid	0.75 mm ² –4 mm ²			
Connection, Stranded	0.75 mm ² –4 mm ²			
Enclosure Material	UL® 94 V-0 Thermoplastic			
Enclosure Rating	IP 20			
Temperature	–40 to 85°C			
Depth (D)	10.72 cm			
Height (H)	11.0 cm			
Width (W)	1.8 cm			
Unit Weight	0.10 kg			
Complies With	AREMA® C&S Manual Parts 11.5.1, 11.3.2, 14.1.2; ANSI®/IEEE® C62.41.2-2002 Cat A, Cat B, Cat C			
Color	Red	Black	Purple	Yellow
Replacement Module	RTBN12M	RTBN30M	RTBN50M	RTBN130M

Remote Transmitter Protector

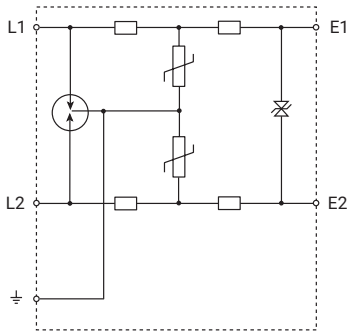
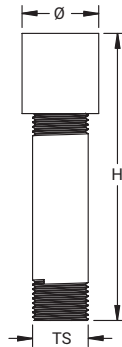

Features

- Three stage protection and fine over-voltage protection helps ensure lowest residual surge voltage reaches sensitive equipment
- Flexible installation allows enclosure to be installed "dead ended", "T" configured or in-line
- Optimized for protection of 2-wire industrial 4-20 mA loops and suitable for exposed locations
- Supports line currents up to 145 mA and protects 24 VDC powered equipment



Part Number	RTP3034
Nominal System Voltage (U_n)	21 VAC 30 VDC
Max Continuous Operating Voltage (U_o)	23 VAC 33 VDC
Voltage Protection Level (U_p), L-L	44 V @ 3 kA
Max Discharge Current (I_{max}), L+L-PE	20 kA 8/20 μ s
Rated Load Current (I_L)	145 mA
Loop Resistance	14 Ω
Protection Modes	Common Differential
Technology	Gas Discharge Tube (GDT); Metal Oxide Varistor (MOV); Silicon Avalanche Diode (SAD)
Enclosure Material	Stainless Steel
Enclosure Rating	IP 55
Temperature	-40 to 65°C
Thread Size (TS)	3/4 NPT
Diameter (\varnothing)	3.5 cm
Height (H)	12.7 cm
Designed to Meet	ANSI®/IEEE® C62.41.2-2002 Cat A, Cat B, Cat C
Certifications	CE; Qualifoudre
Standard Packaging Quantity	1 pc
UPC	78285652666
EAN-13	8711893027549

Load Cell Protector

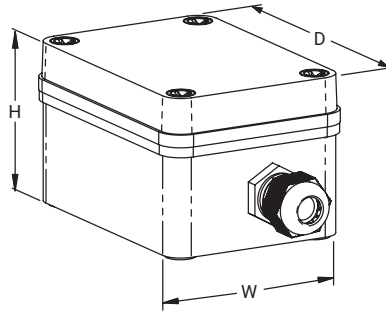

Features

- Six wires and shield protection works with four or six wire systems
- Suitable for compression or tension cells
- Low series impedance, loadcells do not need recalibration
- NEMA®-12 (IP-55) rated, suitable for outdoor use
- Helps protect against excitation over-voltage and prevent loadcell damage

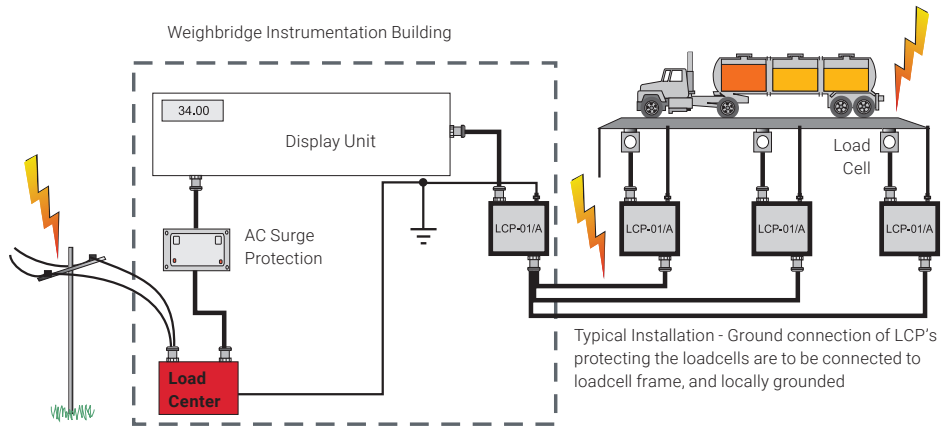
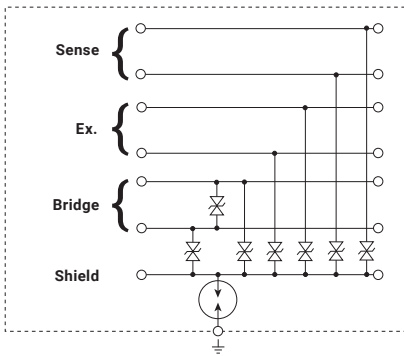

Part Number	LCP01A
Max Discharge Current (I_{max}), Shield to Ground	10 kA 8/20 μ s
Max Discharge Current (I_{max}), Signal to Shield	0.3 kA 8/20 μ s
Voltage Protection Level (U_p), Shield to Ground	90 V
Voltage Protection Level (U_p), Signal to Shield	30 V
Voltage Protection Level (U_p), Signal to Signal	15 V
Loop Resistance	0.3 Ω
Technology	Silicon Avalanche Diode (SAD)
Material	Acrylonitrile Butadiene Styrene
Enclosure Rating	NEMA® 12 (IP55)
Depth (D)	11.0 cm
Height (H)	5.6 cm
Width (W)	7.5 cm
Unit Weight	0.25 kg
Temperature	-40 to 80°C
Certifications	Qualifoudre
Standard Packaging Quantity	1 pc
UPC	78285644014
EAN-13	9321098000804

NEMA is a registered service mark of National Electrical Manufacturers Association.

Surge Counter, Digital Display

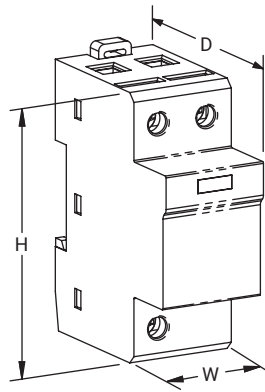

Features

- Records time and date of transient surge events
- Resettable counter
- Snap on, hall effect transducer

Part Number	DSCL2
Trip Threshold	100 A 8/20 μ s
Status Indication	LED
Connection, Stranded	70 mm ² Max
Lead Length	50.8 cm
Enclosure Material	UL [®] 94 V-0 Thermoplastic
Enclosure Rating	IP 20 NEMA [®] -1
Mounting	35 mm top hat DIN rail
Temperature	-20 to 70°C
Module Width	2 M
Depth (D)	6.8 cm
Height (H)	9.0 cm
Width (W)	3.6 cm
Unit Weight	0.19 kg
Standard Packaging Quantity	1 pc
UPC	78285680444
EAN-13	8711893146950

Potential Equalization Clamp

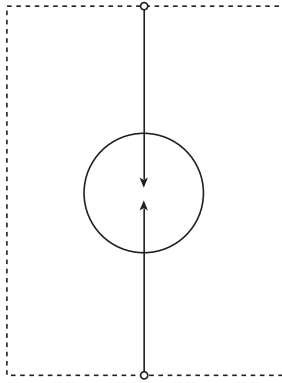
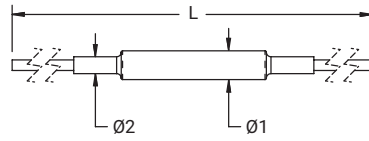

Features

- High peak current capability provides long service life
- Weatherproof enclosure is suitable for direct burial
- The PEC100 is ATEX approved and suitable for use in potentially explosive atmospheres



Part Number	PEC100
Spark-Over Voltage @ 100 V/s	350 V
Max Discharge Current (I_{max})	100 kA 8/20 μ s
Technology	Gas Discharge Tube (GDT)
Insulation Resistance	1 G Ω Min
Capacitance	15 pF Max
Voltage Protection Level (U_p)	800 V @ 1,000 V/ μ s
Impulse Current (I_{imp})	25 kA 10/350 μ s
Lead Length	43.2 cm
Lead Size	16.8 mm ²
Enclosure Rating	IP 66; IP 67
Temperature	-30 to 70°C
Diameter 1 ($\varnothing 1$)	2.8 cm
Diameter 2 ($\varnothing 2$)	1.6 cm
Length (L)	95.6 cm
Unit Weight	0.50 kg
Complies With	IEC® 61643-1 Class I, Class II IEC® 62561-3
Certifications	ATEX Baseefa13ATEX0113X CE; IECEx BAS 13.0065X; Qualifoudre
EAN-13	9321098000804
Standard Packaging Quantity	1 pc
UPC	78285656478
EAN-13	8711893027570

Spark-over voltage has a tolerance of +/-20%.
IEC is a registered trademark of the International Electrotechnical Commission.

MOV/GDT/SAD Tester MGATESTER1

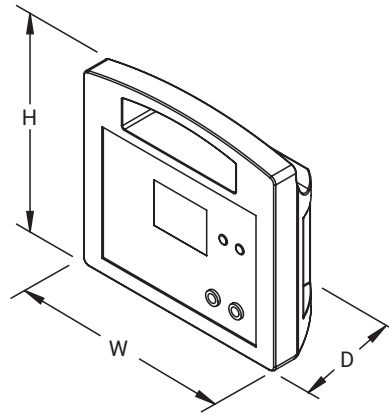

Features

- Measurement of metal oxide varistors, gas discharge tubes, and avalanche diodes
- Ability to display up to 50 measurements
- Adjustable test settings
- Rechargeable battery

nVent ERICO testers are designed for rapid testing of the integrity of surge protection device components. Because standard metal oxide varistors, gas arresters, and avalanche diodes do not provide the user with a visual indication of the integrity of the protection capacity, an external means of testing is required. It is impossible to predict when these failures will occur without some form of testing.

As MOVs approach the end of their life cycle, they exhibit a change in tolerance levels. nVent ERICO testing products are specifically designed to identify these situations and allow the operator to effect remedial replacement to the devices which are nearing the end of their life cycle. They can test both components, as well as replacement modules such as the TDS or DSD

Part Number	MGATESTER1
Test Voltage	1,500 VDC Max
GDT Voltage Ramp	100 V/s 1,000 V/s
MOV/SAD Test Current	0.1 mA 0.5 mA 1.0 mA
Enclosure Rating	IP 20
Temperature	10–50°C
Depth (D)	8.2 cm
Height (H)	20.5 cm
Width (W)	22.0 cm
Unit Weight	0.95 kg
Standard Packaging Quantity	1 pc
UPC	78285691000

Glossary of Terminology

8/20 μ s CURRENT WAVESHAVE

A current impulse with a virtual front time of 8 μ s and a time to half-value of 20 μ s.

AGGREGATE SURGE RATING

The sum of the surge ratings of individual voltage limiting components, connected in parallel, in the device.

Note: This figure does not indicate the maximum discharge current (I_{max}) of the device. It does however provide an indication of the expected SPD life. Users should be aware that certain manufacturers may incorrectly claim the aggregate surge rating of MOV material used in their device as its I_{max} . Non-perfect current sharing between parallel MOVs, and the inability of series over-current or thermal disconnects to carry the full surge current, generally means that the maximum discharge current which the SPD can withstand is less than its aggregate surge rating.

ATTENUATION

The ability of an SPD to reduce electrical noise interference, measured in decibels. Attenuation varies with frequency, so it is usual to specify the attenuation of the SPD at a particular frequency; commonly 100 kHz.

BACKUP OVERCURRENT PROTECTION

An external overcurrent protective device installed prior to the SPD. Such a device may be required if the overcurrent limiting device on the service is larger than that required by the SPD or connecting wiring.

Class I test

SPD tested with maximum impulse current (I_{imp}) and nominal discharge current (I_n).

Class II test

SPD tested with maximum discharge current (I_{max}) and nominal discharge current (I_n).

Class III test

SPD tested with combination wave.

DISTRIBUTION SYSTEM

Defines the electrical power distribution system. The distribution system is usually described by configuration of the phases, neutral and ground conductor configuration on the secondary side of the supply transformer. Refer to pages 10-12 for further information.

FOLLOW CURRENT (I_f)

The current supplied by the electrical power distribution system which flows through the SPD after a discharge current impulse. The follow current is significantly higher than the operating current, and is normally high for voltage switching type SPDs (e.g. spark gaps) since the arc voltage falls below the AC supply voltage after firing.

IMPULSE CURRENT (I_{imp})

Peak impulse current withstand with a 10/350 μ s current waveshape. This is often used for the classification of SPDs tested to Test Class I, but is not the only acceptable waveshape.

INSERTION LOSS

The insertion loss of an SPD is usually only stated for two port devices for use on low voltage data systems. It is a measure of the ratio of voltage at the output to the input at the device under test. The insertion loss is usually stated for a given frequency and measured in decibels.

LEAKAGE CURRENT

The current flowing to the ground conductor when the SPD is connected to the nominal supply voltage U_n .

LET-THROUGH VOLTAGE

Another term often used to describe the measured limiting voltage.

Note: This measurement may be carried out with, or without, the presence of the nominal AC power (U_n) being applied to the SPD. As such, the results may be different and the user should take cognizance of this in making any comparative assessments.

LOCATION CATEGORIES

Various standards attempt to define the electrical environment at which an SPD may be installed, into location categories or zones.

Note: The user should be aware that international consensus has not been reached on these classifications, nor on the size of expected surge activity, which may occur. Further, the user should note that the demarcation of these zones do not form literal boundaries, but are rather a gradual transition.

MAXIMUM CONTINUOUS OPERATING VOLTAGE (U_c)

The maximum r.m.s. or d.c. voltage which may be continuously applied to the SPD's mode of protection without degradation or inhibiting its correct operation.

Note: Specifications given in the catalog generally are phase (L-N) voltages.

MAXIMUM DISCHARGE CURRENT (I_{max})

The maximum single shot current, having an 8/20 μ s waveshape, which the SPD can safely divert.

MEASURED LIMITING VOLTAGE

The maximum voltage measured across the SPD's terminals during the application of an impulse of specified waveshape and amplitude.

MODES OF PROTECTION

SPDs may provide protection line-to-ground, line-to-neutral, neutral-to-ground or in combinations thereof. These paths are referred to as the modes of protection.

Note: The user is advised that not all modes require protection, and more is not necessarily better when selecting an SPD. As an example, the N-G mode is not required when the SPD is installed at the primary service entrance of a TN-C-S electrical distribution system, due to the Neutral-Ground bond at this point. The L-L mode is generally not provided for systems with neutral conductors since the L-N modes also protect the L-L modes. Similarly, the L-G mode can be protected via the L-N and N-G modes.

NOMINAL DISCHARGE CURRENT (I_n)

The peak value of the current flowing through the SPD during the application an 8/20 μ s waveshape.

Note: IEC 61643-1 requires SPDs tested to Test Class II, to withstand 15 impulses at I_n followed by 0.1, 0.25, 0.5, 0.75 and 1.0 times I_{max} .

NOMINAL (SYSTEM) VOLTAGE (U_n)

The L-N voltage by which an electrical power system is designated. Under normal system conditions, the voltage at the supply terminals may differ from the nominal voltage as determined by the tolerance of the supply system (normally +/-10%).

Glossary of Terminology

ONE-PORT SPD

An SPD connected in shunt (parallel) with the circuit to be protected. A one port device may have separate input and output terminals, but without a specific series impedance between these terminals. This type of connection is also known as a Kelvin connection.

Operating Current

The current drawn (per phase) by the SPD when energized at the nominal operating voltage U_n .

Note: For SPDs with integral series filtering, the total current drawn may be greater than the real rms current consumption (i.e. VA may be greater than Watts). This is due to the presence of the internal filtering capacitance.

OVER-CURRENT PROTECTION

An over-current device, such as a fuse or circuit-breaker, which could be part of the electrical distribution system located externally and up-stream of the SPD. May provide protection to the SPD, the connecting wiring and provide a means of externally isolating the SPD.

PROTECTIVE EARTH (PE)

The IEC® 60364 series characterizes low-voltage distribution systems by their grounding methods and the configuration of the neutral and protective conductors. The Protective Earth is commonly referred to as "ground", or "earth", in many regions.

RATED LOAD CURRENT (I_L)

Maximum continuous rated current that can be supplied to a load connected to the protected output of an SPD. Normally only stated for two port, series connected, SPDs.

RESIDUAL VOLTAGE

In IEC terminology this refers to the peak value of the voltage that appears between the terminals of an SPD due to the passage of discharge current I_n . NZS/AS 1768 refers to this as the let-through voltage, a measurement obtained when the stated test impulse is superimposed on top of the nominal system voltage U_n .

SECONDARY SURGE ARRESTER

A loosely used term given to SPDs intended for operation on medium voltage systems (>1 kV). Within the USA, a secondary surge arrester defines an SPD Listed by Underwriters Laboratories Inc. for use on LV and MV systems at locations prior to the main overcurrent disconnect to the facility.

Note: Secondary Surge Arrester Listing is generally considered to have less demanding safety requirements than those for UL® 1449 Transient Voltage Surge Arrester Listing.

SHORT CIRCUIT CURRENT RATING (SCCR)

The short-circuit current rating of the SPD. Required by USA National Electric Code (NEC®) for TVSS devices.

SPD DISCONNECTOR

An IEC term used to describe a device (internal and/or external) for disconnecting an SPD from the electrical power system.

Note: This disconnecting device is not required to have isolating capability. It is to prevent a persistent fault on the system and is used to give an indication of the SPD failure. There may be more than one disconnecter function, for example an over-current protection function and a thermal protection function. These functions may be integrated into one unit or performed in separate units.

SPARK-OVER VOLTAGE

The voltage at which a switching type SPD (generally of the spark gap type) will initiate conduction. This value is normally specified for a voltage increasing at 1 kV/s.

STATUS INDICATOR

A device(s) that indicates the operational status of the SPD, or of a particular mode of its protection.

Note: Such indicators may be local with visual and/or audible alarms and/or may have remote signaling and/or output contact capability.

SUPPRESSED VOLTAGE RATING (SVR)

A special case of the measured limiting voltage specific to the UL 1449 Listing of an SPD.

Note: This test is performed using a small 500 A 8/20 μ s current limited impulse, and the clamping voltage recorded at the ends of 6" connecting leads. The result obtained is rounded up to the nearest value given in a table.

SURGE PROTECTION DEVICE (SPD)

An IEC term used to describe a device intended to limit transient over-voltages and divert surge currents. It contains at least one non-linear component.

SURGE (REDUCTION) FILTER

A two-port series filtering type of SPD specifically designed to reduce the rate-of-rise of voltage (dv/dt) of the pre-clamped waveform. Such a device normally contains a filter with low-pass performance.

TWO-PORT SPD

An SPD with two sets of terminals, input and output (line and equipment), and with a specific impedance inserted between these terminals. These are often referred to as series (in-line) connected SPDs and generally contain wave-shaping filters in addition to simple shunt-only protection.

VOLTAGE PROTECTION LEVEL (U_P)

Similar to the measured limiting voltage, the voltage protection level characterizes the performance of an SPD in limiting the voltage across its terminals.

Note: The voltage protection level is the measured limiting voltage recorded under a specified current magnitude and waveshape, and rounded up to the next highest voltage selected from a list of preferred values found in IEC 61643-1 Standard for surge protective devices connected to low-voltage power distribution systems. For SPDs tested to Test Class I, U_P is generally stated using a 10/350 I_{imp} and for SPDs tested to Test Class II, using an 8/20 μ s I_{max} .

VOLTAGE PROTECTION RATING (VPR)

A rating selected from a list of preferred values as given in Table 63.1 of ANSI®/UL 1449 and assigned to each mode of protection. The value of the VPR is determined as the nearest highest value taken from Table 63.1 to the measured limiting voltage determined during the transient-voltage surge suppression test using the combination wave generator at a setting of 6 kV, 3 kA.



©2024 nVent. All nVent marks and logos are owned or licensed by nVent Services GmbH or its affiliates. All other trademarks are the property of their respective owners.
nVent reserves the right to change specifications without notice.
ERICO-CAT-E1330C-SurgeProtectionSolutions-USEN-2406



For more information
Call 0800 367 229 | sales@colterlec.co.nz | www.colterlec.co.nz